



PHYSICAL SCIENCES

PHYSICAL SCIENCES

CLASS

9



CLASS IX

2025-26

2025-26



State Council of Educational Research and Training
Telangana, Hyderabad



Published by
The Government of Telangana
Government's Gift for Students' Progress



Energized Text Books facilitate the students in understanding the concepts clearly, accurately and effectively. Content in the QR Codes can be read with the help of any smart phone or can as well be presented on the Screen with LCD projector/K-Yan projector. The content in the QR Codes is mostly in the form of videos, animations and slides, and is an additional information to what is already there in the text books.

This additional content will help the students understand the concepts clearly and will also help the teachers in making their interaction with the students more meaningful.





At the end of each chapter, questions are provided in a separate QR Code which can assess the level of learning outcomes achieved by the students.

We expect the students and the teachers to use the content available in the QR Codes optimally and make their class room interaction more enjoyable and educative.

Let us know how to use QR codes

In this textbook, you will see many printed QR (Quick Response) codes, such as 

Use your mobile phone or tablet or computer to see interesting lessons, videos, documents, etc. linked to the QR code.

Step	Description
A.	Use Android mobile phone or tablet to view content linked to QR Code:
1.	Click on Play Store on your mobile/ tablet.
2.	In the search bar type DIKSHA .
3.	
	will appear on your screen.
4.	Click Install
5.	After successful download and installation, Click Open
6.	Choose your preferred Language - Click English
7.	Click Continue
8.	Select Student/ Teacher (as the case may be) and Click on Continue
9.	On the top right, click on the QR code scanner icon  and scan a QR code  printed in your book
	OR
	Click on the search icon  and type the code printed below the QR code, in the search bar. (Q)
10.	A list of linked topics is displayed
11.	Click on any link to view the desired content
B.	Use Computer to view content linked to QR code:
1.	Go to https://diksha.gov.in/teelangana
2.	Click on Explore DIKSHA-TELANGANA
3.	Enter the code printed below the QR code in the browser search bar (Q)
4.	A list of linked topics is displayed
5.	Click on any link to view the desired content



IN ANY EMERGENCY
DIAL
100
TELANGANA POLICE
www.tspolice.gov.in

  @ **Telangana State Police**



Government of Telangana
Department of Women Development & Child Welfare - Childline Foundation

CHILD LINE 1098
 NIGHT & DAY
 24 HOUR NATIONAL HELPLINE

When abused in or out of school. → To save the children from dangers and problems.
 When the children are denied school and compelled to work. → When the family members or relatives misbehave.

1098 (Ten...Nine...Eight) dial to free service facility.

PHYSICAL SCIENCES

CLASS IX

SCERT, TELANGANA

Published by the Government of Telangana, Hyderabad.

Respect the Law
Get the Rights

Grow by Education
Behave Humbly



© Government of Telangana, Hyderabad.

First Published 2013
New Impressions 2014, 2015, 2016, 2017, 2018, 2019, 2020, 2021, 2022, 2023, 2024,
Republished-2025

All rights reserved.

No part of this publication may be reproduced, stored in a retrieval system, or transmitted, in any form or by any means without the prior permission in writing of the publisher, nor be otherwise circulated in any form of binding or cover other than that in which it is published and without a similar condition including this condition being imposed on the subsequent purchaser.

The copy right holder of this book is the Director of School Education, Hyderabad, Telangana. We have used some photographs which are under creative common licence. They are acknowledge at the end of the book.

This Book has been printed on 70 G.S.M. Maplitho,
Title Page 200 G.S.M. White Art Card

Free Distribution by Government of Telangana 2025-26

Printed in India
at the Telangana Govt. Text Book Press,
Mint Compound, Hyderabad,
Telangana.

తెలంగాణ ప్రభుత్వం

పాఠశాల విద్యారాఖి



తెలంగాణ తీర్తి

Published by the Government of Telangana, Hyderabad.

తెలంగాణ ప్రభుత్వ ప్రచురణ, హైదరాబాదు.

State Song

1. Jaya jayahe Telangana jananee jayakethanam
Mukkoti gonthukalu okkataina chethanam
Tharatharaala charithagala thallee neerajanam
Padapadaana nee pillalu pranamillina shubha tharunam
Jai Telangana jai jai Telangana
Jai Telangana jai jai Telangana
2. Pampanaku Janmanichi Badhenaku padyamichi
Bheemakaviki Chanubala beejaksharamaina thalli
Haaluni Gaathasapthashathiki vuyaloodina nela
Bruhatkathala Telangana kotilingala kona
Jai Telangana jai jai Telangana
Jai Telangana jai jai Telangana
3. Prajala bhashalo kavya pramaanalu prakatinchina
Telugulo toli prajakavi Palakurki Somanna
Rajyaanne dhikkarinchi Ramulori gudinigatti
kavirajai velige dishala kancharla Gopanna
Jai Telangana jai jai Telangana
Jai Telangana jai jai Telangana
4. Kaalidasa Kaavyalaku bhaashyalanu raasinatti
Mallinaathasoori ma Methukuseema kannu bidda
Dhulikattanelinatti Boudhaniki bhanduvathadu
Dignaguni ganna nela dhikkarama janma hakku
Jai Telangana jai jai Telangana
Jai Telangana jai jai Telangana
5. Potanadi puritigadda Rudramadee veeragadda
Gandara gandadu Komuram Bheemude nee bidda
Kakatiya kalaaprabhala kanthirekha Ramappa
Golukonda Bhaagyanagari goppavelugu Charminaru
Jai Telangana jai jai Telangana
Jai Telangana jai jai Telangana
6. Rachakonda elubadiga ranjillina Recharla
Sarvagna Singa Bhupaluni bangaru bhoomi
Vani naa rani antu ninadinchina kavikularavi
pillalamarri pina veerabhadruudu malo rudruudu
Jai Telangana jai jai Telangana
Jai Telangana jai jai Telangana
7. Sammakkalu Saarakkalu Sarvai Paapannalu
Sabbanda varnaala sahasaalu koniyaduthu
Ooroora paatalaina Meerasaabu veeragatha
Dandu nadipe Palamooru Pandugolla Sayanna
Jai Telangana jai jai Telangana
Jai Telangana jai jai Telangana
8. Kavigaayaka vaithaalika kalalaa manjeeralu
Dappu dhamarukamu dakki Sharada swara naadhalu
Pallavulaa chirujallula prathi ullamu ranjillaga
Anunityam nee gaanam Amma neeve maa praanam
Jai Telangana jai jai Telangana
Jai Telangana jai jai Telangana
9. Jaanapada janajeevana jaavaleelu jaaluvaara
Kavi gaayaka vaithaalika kalalaa manjeeraalu
Jaathini jaagruthaparache geethaala jana jaathara
Anunithyam nee gaanam Amma neeve maa praanam
Jai Telangana jai jai Telangana
Jai Telangana jai jai Telangana
10. Badula gudulatho pallala odalu pulakarinchali
virise janavignanam nee keerthini penchali
Tadabadakundaa jagaana thala etthukoni brathuka
oka jaathiga nee santhathi oyamma velagaali
Jai Telangana jai jai Telangana
Jai Telangana jai jai Telangana
11. Siri velugulu jimme Singareni nalla bangaram
Anuvuvuna khanijale nee thanuvuna singaram
Sahajamaina vanasampada sakkanaina puvvula poda
Sirulu pande saramunna maagaanama kada nee yeda
Jai Telangana jai jai Telangana
Jai Telangana jai jai Telangana
12. Godavari krushnammalu thallee ninu thadupangaa
Pachchani maa nelallo pasidi sirulu pandanga
Sukhasaanthula Telangana subhikshanga undaale
Prathi dinamadi Telangana prajala kalalu pandaali
Jai Telangana jai jai Telangana
Jai Telangana jai jai Telangana

- Andhe Sri

NATIONAL ANTHEM



*Jana-gana-mana-adhinayaka, jaya he
Bharata-bhagya-vidhata.
Punjab-Sindh-Gujarat-Maratha
Dravida-Utkala-Banga
Vindhya-Himachala-Yamuna-Ganga
Uchchhala-jaladhi-taranga.
Tava shubha name jage,
Tava shubha asisa mage,
Gahe tava jaya gatha,
Jana-gana-mangala-dayaka jaya he
Bharata-bhagya-vidhata.
Jaya he! jaya he! jaya he!
Jaya jaya jaya, jaya he!!*

- Rabindranath Tagore

PLEDGE

“India is my country; all Indians are my brothers and sisters.
I love my country, and I am proud of its rich and varied heritage.

I shall always strive to be worthy of it.

I shall give my parents, teachers and all elders respect,
and treat everyone with courtesy. I shall be kind to animals.

To my country and my people, I pledge my devotion.

In their well-being and prosperity alone lies my happiness.”

- Pydimarri Venkata Subba Rao



THE CONSTITUTION OF INDIA

Preamble

WE, THE PEOPLE OF INDIA, having solemnly resolved to constitute India into a **SOVEREIGN SOCIALIST SECULAR DEMOCRATIC REPUBLIC** and to secure to all its citizens:

JUSTICE, social, economic and political;

LIBERTY of thought, expression, belief, faith and worship;

EQUALITY of status and of opportunity; and to promote among them all

FRATERNITY assuring the dignity of the individual and the unity and integrity of the Nation;

IN OUR CONSTITUENT ASSEMBLY this twenty-sixth day of November, 1949 do **HEREBY ADOPT, ENACT AND GIVE TO OURSELVES THIS CONSTITUTION.**



Foreword

The nature is life source for all living organisms. Though it usually appears simple and normal, the intricacies of the very nature often challenges us to untie the tough knots of its hidden secrets, day in and day out. That is why, Galileo Galilei, the Italian astronomer, emphasized that scientific learning is nothing but improving the ability of questioning. The classroom teaching of science must be in such a way that it encourages children to think and work scientifically.

This textbook designed to help students achieve Science Education objectives such as scientific perspective, scientific attitude, the ability to develop scientific process skills, the using principles, theories, rules and functional relationships. Based on the recommendations of National Curriculum Framework - 2005, Right to Education Act - 2009, and Curriculum Framework Document - 2011, the curriculum provides students with experiential learning to enhance their learning.

Textbooks are designed to achieve the desired learning outcomes. Teachers should devise suitable teaching strategies to enhance the expected learning outcomes in children by the end of the class. A move away from rote learning approaches is necessary for the effective implementation of continuous comprehensive assessment. Teachers need to be aware of the methods needed to evaluate children's progress through formative and summative methods. It is very useful for teachers and students that textbooks not provide content but also reflect teaching methods and assessment methods.

This book has been energized with QR (Quick Response) codes to facilitate the students in understanding the concepts clearly.

We thank the Vidya Bhawan Society, Rajasthan, College of Engineering Osmania University and ELTC, DIET Hyderabad for their cooperation in developing these new text books. Our special thanks to Faculty of School of Education Tata Institute of Social Sciences (TISS), Hyderabad and Communication Officer, CETE, TISS-Mumbai and Designers identified by SCERT for their technical support in redesigning of the textbooks. The writers for preparing the lessons, the editors for checking the textual matters and the DTP group for cutely composing the text book.

**Director,
SCERT, Hyderabad**



INDEX

<i>Name of the Chapter</i>	<i>Periods</i>	<i>Month</i>	<i>Page No.</i>
1 <i>Matter around us</i>	06	June	1
2 <i>Motion</i>	11	June/July	11
3 <i>Laws of motion</i>	10	July	31
4 <i>Refraction of light at plane surfaces</i>	10	August	47
5 <i>Gravitation</i>	10	Aug/Sept	67
6 <i>Is matter pure?</i>	10	September	82
7 <i>Atoms and molecules and chemical reactions</i>	12	Oct/Nov	100
8 <i>Floating bodies</i>	10	November	129
9 <i>What is inside the atom</i>	08	November	149
10 <i>Work and energy</i>	11	December	166
11 <i>Heat</i>	10	January	190
12 <i>Sound</i>	10	February	207
<i>Revision</i>		March	



The word "matter" has very specific meaning in science. Let us try to understand the concept of matter.

You have learnt about metals, non-metals; synthetic and natural fibres, acids and bases etc., in previous classes. These are all examples of matter. All the things around us which exist in a variety of shapes, sizes and texture are also examples of 'matter'.

The water we drink, our food, clothes and various things that we use in our day to day life, the air we breathe, even our body etc., are examples of matter.

What is matter?

Anything in this world that occupies space and has mass is considered as matter.

1.1 States of matter

In previous classes, you had learnt that water can exist as a solid (ice), a liquid or as a gas (water vapour). We say that solid liquid and gas are three different states of matter. Water can be found in all these states.

- Is there any substance which can be found in three states like water?

Now look carefully at different objects around you. You can classify them, into one of the three states of matter.

For example, you can say that wood and coal are solids and petrol is a liquid.

Milk is also a liquid like petrol. But the properties of petrol and milk are quite different from each other.

- What are the properties that lead us to consider petrol or milk as liquids?

Let us do some activities to understand the properties of solids, liquids and gases.

1.2 Properties of solids, liquids and gases

Shape and volume

- Do solids have definite shape and fixed volume?

Take two solid objects, say a pen and a book, and put them in different containers. Do you find any change in their shape or volume?

You might have seen a wide range of solids in your surroundings.

Imagine dropping a book or a pen on the floor. It does not flow like liquids but remains rigid with a definite shape, distinct boundaries and a fixed volume. This shows that solids have a definite shape and a fixed volume.

Activity-1

Identifying the shape and volume of liquids

For doing this activity, we need a measuring jar (cylinder) and containers of different shapes as shown in fig.--1.

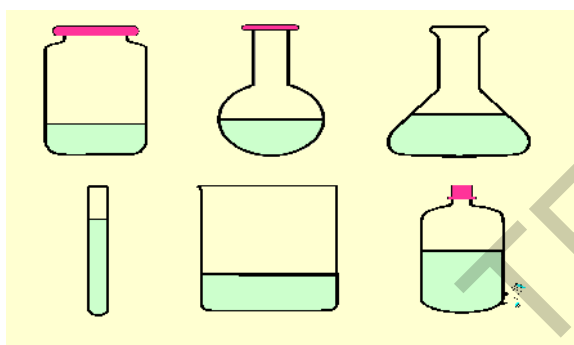

Fig -1: Different shaped containers having liquid of same volume

Note: It is not compulsory to collect same containers as shown in fig.- 1. You can collect the containers of different shapes available to you. We also need some liquids like water oil and milk.

Take some water in one of the containers using the measuring jar. Examine the shape of water in the container. Pour the same water in another container and have a look at the shape, again. Repeat the process till you complete pouring of water in all containers.

- What is the shape of the water in different containers?
- Is the shape of water same or different in all the above cases?
- What shape does water take if it spills on the floor?

Take 50ml of water with the measuring jar and pour it in a tumbler. Mark the level of water on the tumbler and remove water from it. Now measure 50 ml of the milk with the measuring jar and pour it in the same tumbler. Mark the level of the milk on it.

- Are the levels of water and milk same? Remove the milk from the tumbler. Now pour oil into it up to the level marked for water.
- Can you guess the volume of oil?

This activity may seem very simple but we observe two important properties of liquids from this activity.

- 1) The shape of the liquid depends on the shape of the container.
- 2) Though liquid takes different shapes depending on the shape of the container its volume remains same.

Liquids can flow easily. Hence, they are also called "**fluids**".

Look into in a dictionary of science to get the meaning of fluid.

You may find that gases have no fixed shape like liquids. Gases also flow like liquids. Hence both gases and liquids are called fluids. Then what are the differences between liquids and gases?

Activity-2

Do the gases have a definite shape and a fixed volume ?

You might have heard about CNG (Compressed Natural Gas). Go to a CNG pump and ask them where they store CNG. Also see where CNG is stored in a CNG run vehicle. Lastly see how CNG from the pump is transferred to vehicles.

- Does CNG have a fixed volume?
- Does CNG have a definite shape?



Fig - 2: CNG cylinder in a Car

From the observations in the above activity and with our daily life experiences, we can find that CNG and all other gases neither have a fixed shape nor fixed volume.



Fig - 3: CNG filling station



Fig - 4: CNG tank at fuel filling station

1.3 Compressibility

Activity-3

Observing the compressibility of different materials

Take a 50ml syringe. Draw the piston to suck in air. Place your finger on the nozzle and press. Observe depth of piston moved into syringe. Is it easy or hard to press?

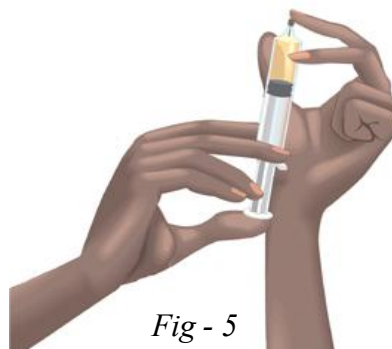

Fig - 5

- Do you find any change in the volume of air in the syringe?

Now fill water in the syringe and press the piston.

- When is it easier to press the syringe with water or air?

Now take a piece of wood and press it with your thumb.

- What do you observe when you press the wood?
- Is there any change in its volume?

From the above observations, you find that gases are highly compressible as compared to liquids and solids.

In our houses liquefied petroleum gas (LPG) is used for cooking. Now a days CNG is used in many automobiles. For all these purposes, large volume of gas is compressed into cylinders of small volume to make it portable.



Think and discuss

- Let us stretch a rubber band. Is there a change in its shape?
- Is rubber band solid or liquid? Why? (What will happen if the stretching is stopped? What will happen if the stretching is too much?)

Take some finely powdered salt (not crystals) and keep it in two different jars.

- Which shape does the powdered salt take?
- Can you say that salt is a liquid on the basis of change in its shape? Justify your answer.
- Take a sponge. Observe its shape. Can you compress it? Is it a solid? Why? Think. Is anything coming out from the sponge when it is compressed.
- Why can't you able to compress a wooden block?

1.4 Diffusion

Activity-4

Observing the diffusion of gases

Ask your friend to hold an unlit incense stick and stand in one corner of the room. Then you go and stand in the other corner.

- Can you smell anything?

Now ask your friend to light the incense stick.

- Can you smell anything now?

When your friend lights the incense stick, the scent in the vapour form and smoke mixes with air and moves across the room and reach our nose.

In this case, smoke, vapour of scent and air are gases and are highly mobile. This type of motion is called diffusion.

If you spray a perfume or deodorant in one corner of the room, it spreads soon to all directions.

- Does the smell from burning incense stick and deodorant spray reach someone on the other end at the same time?

Activity-5

Observing the diffusion of liquids

Take 250 ml round bottomed flask with $\frac{2}{3}$ water in it. Use a dropper and put a few drops of blue or red ink or Potassium permanganate (KMnO_4) solution slowly along the side of flask.



Fig - 6: Diffusion of potassium permanganate in water

- What do you observe after adding the drop of ink or Potassium permanganate?
- You can observe that liquids also diffuse into each other like gases
- How much time does it take the colour to spread evenly throughout water?
- What do you conclude from this activity?

Activity-6

Observing the diffusion of solid particles in to liquids

Take a beaker full of water and add a few crystals of potassium permanganate to it and observe the changes.

Repeat the experiment with crystals of copper sulphate.

- Do you observe diffusion?
- Is it faster or slower than that observed in the activities 4 and 5?

From activities 4, 5, and 6 it is clear that solids and liquids diffuse into liquids and gases diffuse in to gases. Diffusion is the movement of a liquid or gas from an area of higher concentration to an area of lower concentration. The particles will rise until they are evenly distributed.

Certain gases from atmosphere particularly oxygen and carbon dioxide, diffuse and dissolve in water and support the survival of aquatic animals and plants,

Diffusion therefore is a very important process for living things.

During respiration oxygen diffuses from lungs into blood. Carbon dioxide diffuses from blood into lungs.

Solids, liquids and gases diffuse into liquids and rate of diffusion of gases is higher than that of liquids or solids. Do all gases have same speed of diffusion.

Diffusion of gases



Lab Activity

Aim: To observe the speed of diffusion of two gases.

Material required: Long glass tube with scale, liquid Ammonia, Hydrochloric acid, pieces of cotton, two rubber corks and pair of tongs.

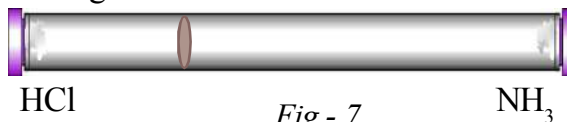

Fig - 7

Note: Teacher should take care of handling hydrochloric acid and prevent the children from touching the acid.

Procedure: Take a one meter long narrow glass tube.

Take two pieces of cotton. Soak one in hydrochloric acid solution and another in ammonia solution. Insert them separately at the two ends of the tube with the help of tongs at the same time as shown in fig-7 and close the ends of the glass tube with rubber cork and observe.

The hydrochloric acid gives off hydrogen chloride gas and ammonia solution gives off ammonia gas. Both gases react together to form a white fumes of ammonium chloride. Observe the white ring in the tube due to formation of ammonium chloride.

Explain

- How did the two gases travel along the tube?
- Which gas travelled faster?

Do this

So far you have studied some properties that can be used to distinguish between solids, liquids and gases. Fill the following table based on your knowledge.

Property	Solid	Liquid	Gas
Shape	fixed		
Volume		fixed	
Compressibility			
Diffusion			

1.5 Can matter change its state?

We started our discussion by recalling that water exists in three states. You must have seen many other materials that can exist in different states.

For example, coconut oil is usually liquid. But on cooling (winter season) it becomes solid.

Camphor is a solid but if we leave it in the open air for some time it directly changes to gas. You may have seen moth balls (naphthalene) being placed in clothes. The smell remains for some time even after the balls disappear. This is because the moth balls have changed from solid state to gaseous state.

Substances absorb heat and change from solid state to liquid state, liquid state to gaseous state. But there are some substances that change directly from solid state to gaseous state and vice versa without passing through the liquid state. We have read about **sublimation** which is one such change.

Solids, liquids and gases are states of matter but you need to think about, why are the properties of same matter different in different states?

- When does water change into ice and then into vapour?
- Why do gases diffuse faster than solids or liquids?

Scientists have tried to explain these facts by examining the physical nature of matter.

What is matter made up of?

All matter is made of very tiny particles. This looks as a simple statement but it is very difficult to explain and understand about matter.

For this we need more details about the particles and their arrangement inside various forms of matter.

Activity - 7

How small are the particles of matter?

Take a beaker with water and add 1 or 2 crystals of potassium permanganate and dissolve them in water.

- What colour do you observe?

Now take out approximately 10ml of this solution and add it to 90ml of clear water in another beaker.

- What does happen to the colour of water in second beaker?

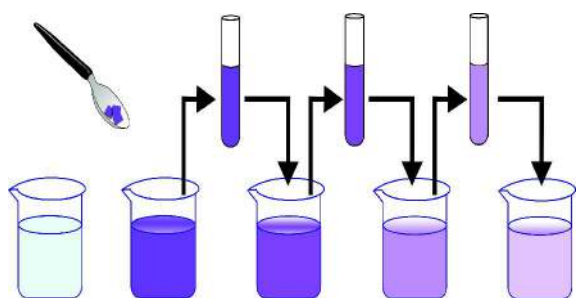

Fig - 8

Again take out 10ml of this solution and add to another 90ml of clear water. Carryout this process 4, 5 times as shown in fig.- 8 and observe changes in intensity of colour of the solution.

- Is the water in the last beaker still coloured?
- How is it possible for two small crystals of potassium permanganate to colour a large volume of water?
- What do you understand from this activity?

Repeat the activity by taking a few crystals of copper sulphate instead of potassium permanganate. Observe the change of colour of water in beaker.

Several interesting conclusions can be drawn from the above activity.

We can conclude that there must be several tiny particles in just one crystal of potassium permanganate, which are uniformly distributed in water to change its colour.

Similarly a few crystals of copper sulphate too has several tiny particles which are distributed in large quantity of water to give colour. So both solid and liquids (including water) are made up of tiny particles.

- How do the particles of the solid distribute in the liquid?

Let us find

Activity - 8

There exists space between particles

Take a graduated beaker and fill it with some water and mark the water level. Add some salt and stir it thoroughly with a glass rod. Observe if there is any change in water level. Add some more salt and stir it again. Observe the change in the level of water.



Fig - 9

- Does the level of water change?
- Where did the salt go?
- Can you see it in the water?

From the activities 7 & 8 we can conclude that liquid particles in a liquid have some space between them and the solid particles enter in to the space between the liquid particles on dissolving solid in liquid.

Recall the incense stick activity. Do you agree that gas is also made up of tiny particles and they have large space between them comparatively liquids and solids.

1.6 Particles of matter attract each other

Activity - 9

Observing the force of attraction between the particles of matter

Open a water tap and allow the water to reach the ground. Now try to stop the stream of water with your finger.

- Are you able to move your finger through the stream of water anywhere from the tap to ground?
- What is the reason behind the stream of water remaining together?

Now try to move your finger through an iron nail, as in the stream of water.

Are you able to do it? If yes, does it rejoin?

- Can you break a piece of chalk? Does it rejoin?

From the above observations we can say that particles of the matter have forces acting between them that keeps the particles together.

It is also clear that this force is not equally strong and different in different forms of matter.

1.7 How diffusion takes place?

We have already carried out several activities to explain diffusion of particles of solids, liquids and gases. Diffusion can be possible only when the particles of matter move continuously.

In the incense stick activity, the particles responsible for scent move and enter the space between the air particles. The scent particles quickly spread across the room.

Particles of solids, liquids and gases can diffuse into liquids and gases. Rate of diffusion of gases is higher than the liquids, while the rate of diffusion of liquids is higher than solids. There are two reasons for higher rate of diffusion of gases.

1. Speed of gas particles is very high.
2. The space between gas particles is very high.

Similarly the greater diffusion rate in liquids compared to solids is because particles in liquids move freely and have greater space between them when compared to particles of solids.

Observe the following diagram which shows the difference in arrangement of particles in solids, liquids and gases.

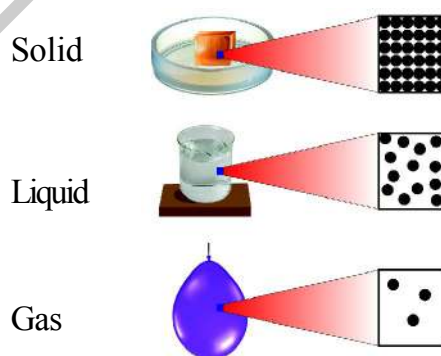

Fig - 10

In a gas the particles are not as close together as in a liquid. If a coloured gas is mixed with a colourless gas, the colour spreads evenly in it. This happens faster in gas than in a liquid, because of large gaps between the particles of gas. Fewer particles of gas obstruct in the way of spreading.

You can see the diffusion of bromine when it diffuses through air. Bromine is a

brownish coloured gas. Hence its diffusion in colourless air can be seen clearly. If we allow Bromine to diffuse in vacuum, it diffuses faster into vacuum, because there are no particles to obstruct in its way.



Key words

Matter, states of matter, solid, liquid, gas, particles, diffusion, compressibility, forces of attraction, compressed natural gas.



What we have learnt

- Matter is made up of particles.
- The particles of matter are very small-they are small beyond our imagination.
- Particles of matter have space between them.
- Particles of matter move continuously in liquids and gases.
- Matter exists in three states i.e., solid, liquid and gas.
- The force of attraction between the particles are maximum in solids, intermediate in liquids and minimum in gases.
- The particles are arranged orderly in the case of solids while particles move randomly in gases.
- Diffusion is possible only when particles of matter move continuously.
- Rate of diffusion of gases is higher than that of liquids (or) solids.



Improve your learning

I. Reflections on Concepts

1. Explain diffusion phenomena based on the states of matter. (AS₁)
2. Mention the properties of solids (AS₁)
3. Mention the properties of liquids (AS₁)
4. Explain "fluid" with one example. (AS₁)
5. Mention the properties of gases. (AS₁)
6. Give two daily life situation where you observe the diffusion. (AS₁)



II. Application of Concepts

1. Mention the applications of compressibility in our daily life? (AS₇)
2. Mention the situations where we use diffusion in our day-to-day life (AS₇)
3. How can we smell perfume sitting several meters away from the source? Predict? (AS₂)
4. How do you prove that the speed of diffusion of ammonia is more than that of the speed of diffusion of hydrochloric acid? (AS₃)
5. Give examples that the matter which will be available in different states. (AS₁)

III. Higher Order Thinking questions

1. We can't rejoin the broken chalk easily. Give reason. (AS₁)
2. Is the space between the particles in the matter influence the speed of diffusion? Explain. (AS₁)



Multiple choice questions

1. Which of the following is available in three states in our daily life (at normal conditions)
(a) Petrol (b) Water (c) Milk (d) Kerosine []
2. Which of the following can be easily compressed to less volume. []
(a) Iron (b) Water (c) Air (d) Wooden piece



Suggested Experiments

1. Conduct an experiment to observe the speed of diffusion of two substances.
2. Conduct an experiment to show the space between the particles of matter and write the report.



Suggested Projects

1. Make a model to explain the structure of particles in solids, liquids and gases.
2. What are the factors influencing diffusion, whether the arrangement of atoms in the substance that diffuse or the arrangement of atoms of the medium in which the substance is kept.
3. Some solids diffuse in liquids but not in gasses, some solids diffuse in gasses but not in liquids. Why?



We are familiar with the idea of motion. We see several examples of motion around us like motion of people, vehicles, trains, aeroplanes, birds, rain drops, objects thrown into air, etc. We know that it is due to the motion of the Earth that phenomena like sunrise, sunset, changes in the seasons etc occur.

- If Earth is in motion, why don't we directly perceive the motion of the Earth?
- Are the walls of your class room at rest or in motion? Why?
- Have you ever experienced that the train in which you sit appears to move when it is at rest? Why?

To give answers to these questions we need to understand the terms 'relative' and 'relative motion'.

Great progress in understanding motion occurred when Galileo undertook his study of rolling balls on inclined planes. To understand motion, we need to understand the meaning of the word 'relative', which plays an important role in explaining motion.

2.1 What is relative ?

We use many statements in our daily life to express our views. The meaning of a statement depends on the context in which it is made.

Does every statement have a meaning?

Evidently the answer is 'no'. Even if you choose perfectly sensible words and put them together according to all the rules of grammar, you may still get complete non-sense. For instance the statement "This water is triangular" can hardly be given any meaning.

A statement has a meaning only when there is a relation between words.

Similarly there exists other situations in our daily life where we use statements having meaning depending upon the situation. Let us observe the following example.

Right and Left

As shown in the fig.-1, two persons A and B are moving opposite to each other on a road.

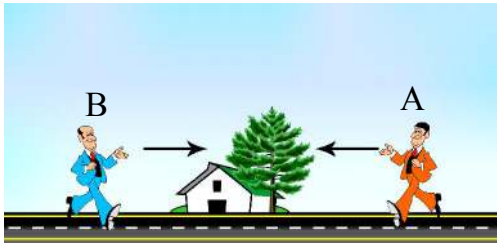

Fig-1

Examine the meaning of the following sentence.

Question: On which side of the road is the house? Is it on the right side or on the left side of the road?

There are two answers for the above question. For person A, the house is on the right and for the person B, the house is on the left. Thus the position of the house is relative to the observer i.e., clearly when speaking of left and right by a person, he has to assume a direction based on which he can decide his left and right sides.

Is day or night just now ?

The answer depends on where the question is being asked. When it is daytime in Hyderabad, it is night in New-York. The simple fact is that day and night are relative notions and our question cannot be answered without indicating the place on the globe where the question is being asked.

Up and down

Can orientations like 'up' and 'down' be the same for all persons at all places? Observe the following fig.- 2.

For the person standing at A on the globe, his position appears up and the orientation of person standing at B appears

down but for the person standing at B it appears exactly opposite. Similarly for the persons standing at the points C and D, the directions of up and down are not same. They change with the point of observation on the globe. Observe the fig-2 by inverting the book

- Why do we observe these changes?

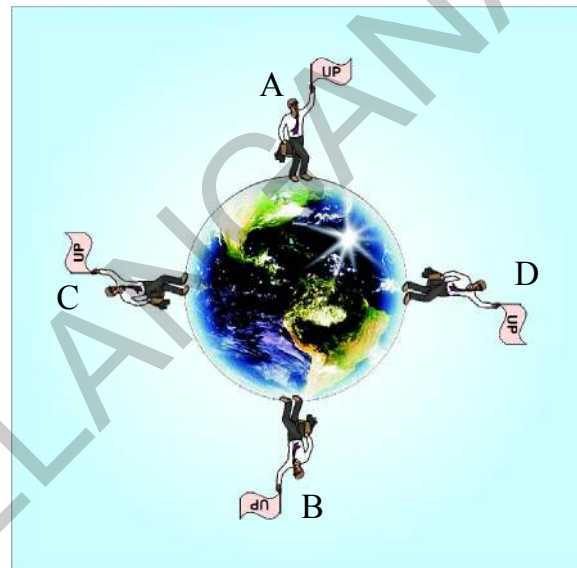

Fig-2

We know that earth is a sphere, the upward direction of the vertical position on its surface depends upon the place on the earth's surface, where the vertical is drawn.

Hence the notions 'up and down' have no meaning unless the point on the Earth's surface, to which they refer, is defined.

Discuss the meaning of the terms 'longer and shorter' with few examples.

- Are these terms relative or not?

Motion is relative

Like the terms right and left, up and down, larger and shorter etc., 'motion' is also relative to the observer.

To understand the idea of motion, let us take the following hypothetical activity.
 Observe and follow the conversation between Srinu and Somesh who stand beside a road as shown in the fig.-3.



Fig-3: Motion in view of Srinu and Somesh

Srinu	:	What is the state of motion of the tree?	Somesh	:	They are also moving like the car.
Somesh	:	Tree is at rest.	Srinu	:	How do you decide that the car, the passenger and the driver are moving?
Srinu	:	What is the state of motion of the car?	Somesh	:	With respect to us, the position of the car, the passenger and the driver are changing with time. So, they are in motion.
Somesh	:	It is moving due east.			
Srinu	:	What is the state of motion of the driver and the passenger in the car?			

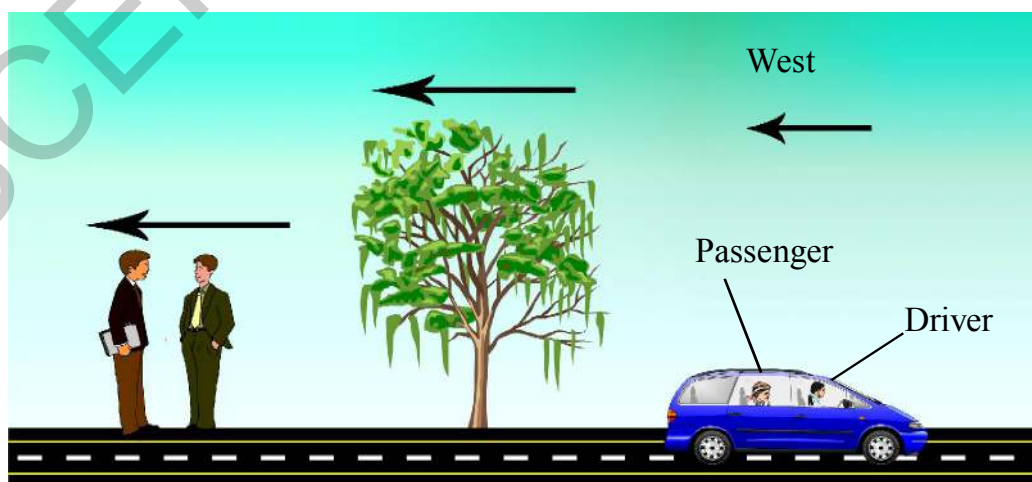

Fig-4: Motion in view of Passenger

Observe the fig.4. Now follow the conversation of the driver and the passenger in moving car.

Driver : What is the state of motion of the tree?

Passenger : It is moving due west

Driver : What is the state of motions of both the persons beside the road?

Passenger : They are also moving due west.

Driver : What is my state of motion?

Passenger : You are at rest.

Driver : What is the state of motion of the car?

- What answer may the passenger give to the driver? Discuss with your friends.

From the above discussion, it is clear that the tree is at rest with respect to Somesh and it is moving due west with respect to passenger.

The 'motion' or 'rest' of an object depends on the observer. So motion is a combined property of the observer and the body which is being observed.

Now we are able to define motion of an object.

A body is said to be in motion when its position is changing continuously with time relative to an observer.

Note: Any object can be taken as a point of observation.

- How do we understand motion?

2.2 Distance and displacement

Activity-1

Drawing path and distinguishing between distance and displacement

Take a ball and throw it into the air with some angle to the horizontal. Observe its path and draw it on paper.

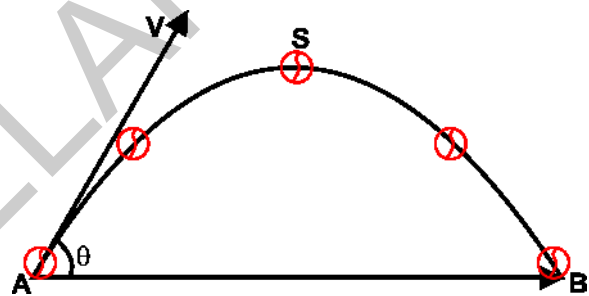
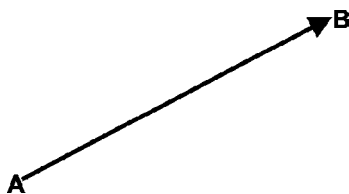

Fig-5: Distance - displacement

Fig- 5 shows the path taken by the ball when it was thrown into air. In the above example (Fig-5), A to S to B shows the path travelled by the ball and is the actual distance travelled by it. AB is the straight line drawn from the initial position to the final position. It shows the shortest distance as well as the direction of the displacement from A to B and is called displacement vector.

To describe a physical situation, some quantities are specified with magnitude as well as direction. Such a physical quantity is called vector. So, displacement is a vector. The physical quantity which does not require any direction for its specification is called scalar. So distance is a scalar.

A vector can be represented as a directed line segment. Its length indicates magnitude and arrow indicates its direction. Point 'A' is called tail or initial point 'B' is called head or end point.



We represent the displacement vector by \vec{AB} . Where A to B straight arrow is the direction and the shortest (straight line) distance AB is the magnitude of the displacement vector \vec{AB} .

- The SI unit of distance and displacement is metre denoted by 'm'.
- Other units like kilometre, centimetre etc. are also used to express this quantity.

$$1 \text{ km} = 1000 \text{ m}$$

$$1 \text{ m} = 100 \text{ cm}$$

Activity-2

Drawing the displacement vectors

A car moves along different paths as shown in figures 6(a) and 6(b). The points A and B are the initial and final positions of the car.

Draw the displacement vectors for two situations given below.

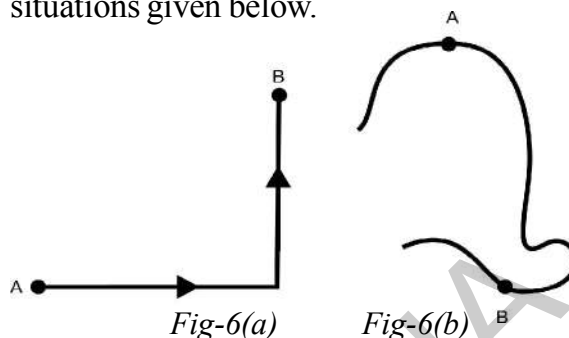

Generally, the distance covered and displacement are time dependent quantities.



Think and discuss

- What is the displacement of the body if it returns to the same point from where it started? Give one example from daily life.
- When do the distance and magnitude of displacement become equal?

2.3 Average speed and average velocity

A train named Telangana express starts at 2.00 pm from Sirpur Kaghaz Nagar and reaches Hyderabad at 8.00 pm the same day as shown in fig.- 7.

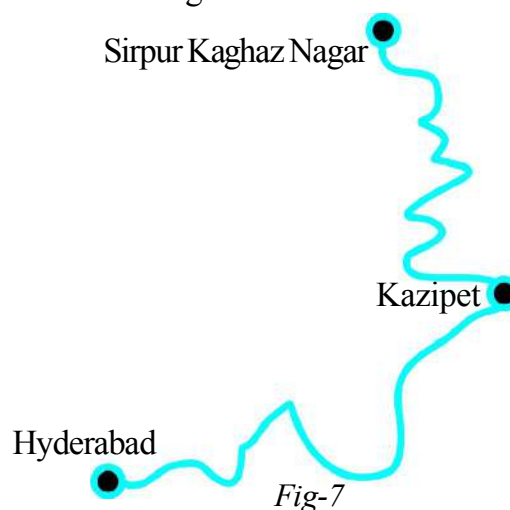

Draw displacement vectors from Sirpur Kaghaz Nagar to Kazipet, Kazipet to Hyderabad and from Sirpur Kaghaz Nagar to Hyderabad.

Let the distance of the entire trip from Sirpur Kaghaz Nagar to Hyderabad be 300 km. The journey time is 6 h. What is the distance covered by the train in each hour?

It is equal to $300\text{km}/6\text{h} = 50\text{km/h}$

Can you say that the train has covered exactly 50 km in each hour?

Obviously the answer is “No”, because there may be some variations in distance covered by the train each hour. So we take the average of distances covered by the train for each hour to decide its average speed. The distance covered by an object in unit time is called average speed.

$$\text{Average speed} = \frac{\text{Total distance}}{\text{Time taken}}$$

Let the displacement of the trip in the above example be 120 km due South–West. What is the displacement in each hour?

$$\begin{aligned} \text{The displacement per hour} \\ &= 120 \text{ km} / 6\text{h South - West} \\ &= 20\text{km} / \text{h South - West} \end{aligned}$$

The displacement of an object per unit time is called average velocity. Average Velocity is a vector and is along the direction of displacement.

$$\text{Average velocity} = \frac{\text{Total Displacement}}{\text{Time taken}}$$

The quantities average speed and average velocity explain the motion of a body in a given time interval. They do not give any information about the motion of the body at a particular instant of time.



Think and discuss

- What is the average speed of the car if it covers 200 km in 5 h?
- When does the average velocity become zero?
- A man used his car. The initial and final odometer readings are 4849 and 5549 respectively. The journey time is 25h. What is his average speed during the journey?

2.4 Speed and Velocity

- ◆ Can you measure the speed and velocity?
- ◆ How can you differentiate average speed and average velocity?

Let us do some activities to understand about speed and velocity.

Activity-3

Measuring the speed

Choose two points (say A & B) 50 meters apart in the school play ground. Ask some students to stand at point A. Ask another group of students with stop watches to stand at B. When you clap your hand, the students at A start running towards the point B in any path. At the same time the students at B start their stop watches.

See that for each runner there is a student at B to measure the time taken for completing the race. Note the time taken by each student to cover the distance between the points A and B in table-1.

Table -1

Student	Time taken to reach B (sec)	Speed m/s
A ₁	t ₁	s ₁
A ₂	t ₂	s ₂
A ₃	t ₃	s ₃

The student who took the least time to reach B (from A) is said to be the fastest runner, i.e., he/she has the greatest speed.

2.4.1 Measuring the average velocity

Repeat the whole activity after drawing a set of parallel straight lines from A to B and ask each student to run along a line (This ensures that each student is covering the same distance along a straight line specified for him/her from A to B)

Measure the time taken by each student and note it in a table-I as shown above and calculate the average velocity of each student. The student who took the least time to reach B from A along the line is said to have run with the greatest velocity.

- What difference did you notice between the two activities?
- Why are we calling the ratio of distance and time as speed in first activity and as velocity in second activity?

Discuss with your teacher.

2.4.2 Speed and Velocity

Objects in motion often have variations in their speeds. For example a car which travels along a street at 50 km/h, get slowed down to 0km/h at a red light and then attain a speed of 30 km/h due to traffic on the road.

- Can you find the speed of the car at a particular instant of time?

You can tell the speed of the car at any instant by looking at its speedometer. The speed at any instant is called **instantaneous speed**.

We can describe the motion of a car moving along a straight road with varying speed using a distance – vs – time graph.

Along the horizontal axis we plot the time elapsed in seconds, and along the vertical axis the distance covered in metres.

A general case of motion with varying speed is shown in fig.- 8.

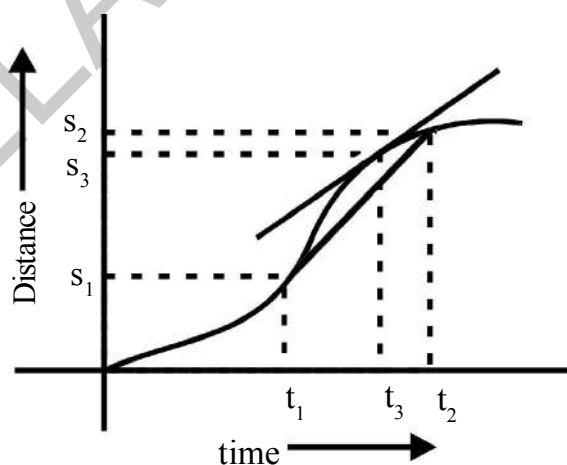

Fig-8: Distance vs time graph

- What is the speed of the car at the instant of time ‘ t₃ ’ for given motion?

We know how to find average speed during the time interval from t₁ to t₂, which includes the instant t₃. It is

$$\text{Average speed} = \frac{S_2 - S_1}{t_2 - t_1}$$

Then we calculate average speed for a very short time interval encompassing the time at an instant t_3 . This interval is so short interval, that the value of average speed would not change materially if it was made even shorter. The instantaneous speed is represented by the slope of the curve at a given instant of time. The slope of the curve gives speed of the car at that instant. If the slope is large, speed is high and if the slope is small, speed is low.

Speed gives the idea of how fast the body moves. In general, bodies move in a particular direction at an instant of interest and this direction may not be constant throughout the journey. So we need to define another quantity called “Velocity”.

Velocity is the speed of an object in a specified direction.

For Example :

A car moves with 15 m/s due east. Here 15 m/s is speed and 15 m/s due east is velocity.

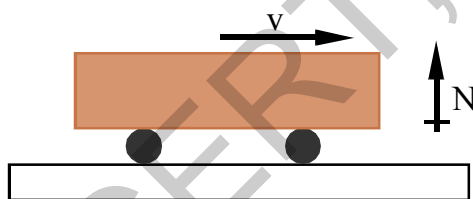

Fig-9

Velocity gives the idea of how fast the body moves in specified direction. Velocity is a vector. It can be represented by a directed line segment. Its length indicates speed and arrow gives the direction of motion.

If a body moves in a curved path, the tangent drawn at a point on the curve gives direction of velocity at that instant.

Observe the following diagram and try to draw tangents (velocity vector) to the curve at different points. Does the direction of velocity of body remain constant or not?

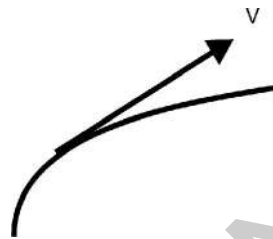

Fig-10: Direction of velocity at a point of path



Think and discuss

- Very often you must have seen traffic police stopping motorists or scooter drivers who drive fast and fine them. Does fine for speeding depend on average speed or instantaneous speed? Explain.
- One airplane travels due north at 300 km/h and another airplane travels due south at 300 km/h. Are their speeds the same? Are their velocities the same? Explain.
- The speedometer of the car indicates a constant reading. Is the car in uniform motion? Explain.

Activity-4

Observing the direction of motion of a body

Carefully whirl a small object or stone tied at the end of the string in the horizontal plane. Release the object while it is whirling on the string.

- In what direction does it move?

Try to release the object at different points on the circle and observe the direction of motion of object after it has been released from the string.

You will notice that the object moves on a straight-line along the tangent to the circle at the point where you released it. The direction of velocity is tangent to the path at a point of interest.

The SI unit of velocity is metre/sec.

In our daily life we must have observed many motions where, in some cases the velocity of an object which is in motion is constant but in other cases it continuously changes.

- Which motion is called uniform? Why?

Let us find out.

2.5 Uniform motion

Activity-5

Understanding uniform motion

Consider a cyclist moving on a straight road. The distance covered by him with respect to time is given in the following table. Draw distance vs time graph for the given values in the table 2.

Table -2

Time (t in seconds)	Distance (s in metres)
0	0
1	4
2	8
3	12
4	16

- What is the shape of the graph?

You will get a graph which resembles the graph shown in fig-11.

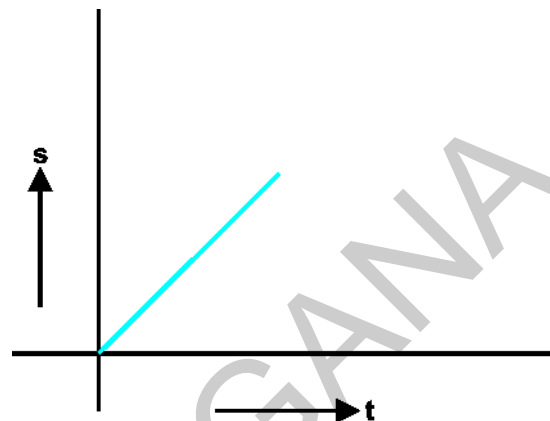

Fig-11

The straight line graph shows that the cyclist covers equal distances in equal intervals of time. From the graph you can understand that the instantaneous speed is equal to average speed. If the direction of motion of the cyclist is assumed as constant then we conclude that velocity is constant.

"The motion of the body is said to be uniform when its velocity is constant."

2.6 Non uniform motion

In our daily life in many situations when a body is in motion, its velocity changes with time. Let us observe the following example.

Consider a cyclist moving on a straight road. The distance covered by him with respect to time is given in the following table. Draw distance vs time graph for the values given in table 3.

Table-3

Time (t in seconds)	Distance (s in metres)
0	0
1	1
2	4
3	9
4	16
--	--

- What is the shape of the graph?
- Is it a straight line or not? Why?

Activity-6

Observing the motion of a ball on an inclined plane

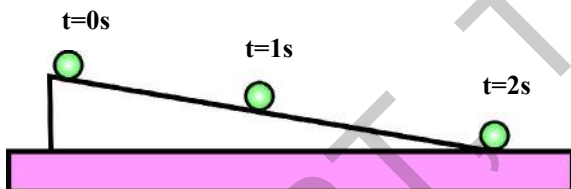

Fig-12: Ball moving down the inclined plane

Set up an inclined plane as shown in fig.- 12. Take a ball and release it from the top of the inclined plane. The positions of the ball at various times are shown in fig.-12.

- What is the path of the ball on the inclined plane?

- How does the velocity of the ball change?

Draw velocity vectors in fig.- 12 at times $t=0s$, $1s$ and $2s$.

On close observation we find that when the ball moves down the inclined plane its speed increases gradually, and the direction of motion remains constant.

Set up an inclined plane as shown in fig.-13. Take a ball and push it with a speed from the bottom of the inclined plane so that it moves up.

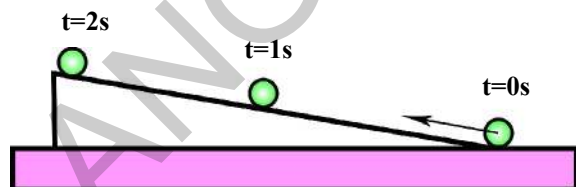

Fig-13: Ball moving up the inclined plane

- What is the path of the ball?
- What happens to its speed?

Draw velocity vectors at times $t=0s$, $1s$, $2s$ in fig.--13.

In above two situations of activity-6, we observe that the speed changes but the direction of motion remains constant.

Activity-7

Observing uniform circular motion

Whirl a stone which is tied to the end of a string continuously. Draw its path of motion and velocity vectors at different positions as shown in the fig.- 14. Assume that the speed of the stone is constant.

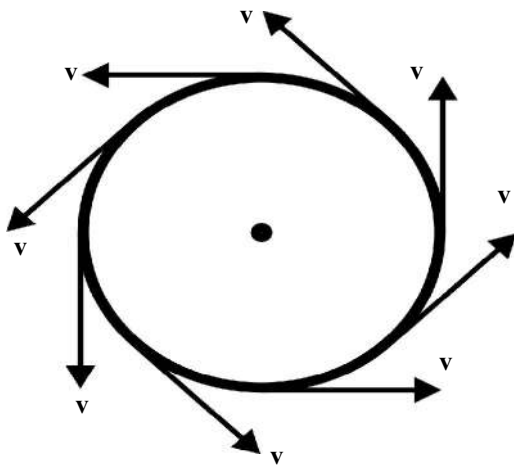

Fig-14

- What is the path of the stone?

It is clear that the path is a circle and the direction of velocity changes at every instant of time but the speed is constant.

Hence in this activity we observe that though speed remains constant, its velocity changes.

- Can you give few examples for motion of an object where its speed remains constant but velocity changes?

Activity-8

Observing the motion of an object thrown into air

Throw a stone into the air while making some angle with the horizontal. Observe the path taken by it. Draw a diagram to show its path and velocity vectors.

- Is the speed of the stone uniform? Why?
- Is the direction of motion constant? How?

In the above activity you might have noticed that the speed and direction of motion both change continuously.

- Can you give some more examples where speed and direction simultaneously change?

From the above three activities you can conclude that the change in velocity takes place in three ways.

1. Speed changes with direction remaining constant.
2. Direction of motion changes with speed remaining constant.
3. Both direction and speed change simultaneously.

"Motion of an object is said to be non-uniform when its velocity is changing."



Think and discuss

- An ant is moving on the surface of a ball. Does its velocity change or not? Explain.
- Give an example of motion where there is a change only in speed but no change in direction of motion.

2.7 Acceleration

We can change the velocity of an object by changing its speed or its direction of motion or both. In either case the body is said to be accelerated. Acceleration gives an idea how quickly the velocity of a body is changing.

- What is acceleration? How can we know that a body is accelerating?

We experience acceleration many times in our day to day activities. For example, if we are travelling in a bus or a car, when the driver presses the accelerator, the passengers sitting in the bus experience acceleration. Our bodies press against the seat due to the acceleration.

Suppose we are driving a car in a given direction. Let us steadily increase the velocity from 30 km/h to 35 km/h in 1sec and then 35 km/h to 40 km/h in the next second and so on.

In the above case the velocity of the car is increasing 5 km/hr. This rate of change of velocity of an object is called **acceleration**.

Acceleration is uniform when equal changes of velocity occur in equal intervals of time. Uniform acceleration is the ratio of change in velocity to time taken.

The term acceleration not only applies to increasing velocity but also to decreasing velocity. For example when we apply brakes to a car in motion, its velocity decreases continuously. We call this as deceleration. We can observe the deceleration of a stone thrown up vertically into the air and similarly we can experience deceleration when a moving train comes to rest.

Let us suppose that we are moving in a curved path in a bus. As the bus travels along the curved path its velocity direction changes continuously. So we also get acceleration with the bus. We experience acceleration that pushes us towards the outer part of the curve.

Observe fig-15. The motion of an object in a curved path at different instants is shown as a motion diagram. The length of the vector at a particular point corresponds to the magnitude of velocity (speed) at that point and arrow indicates direction of motion at every instant.

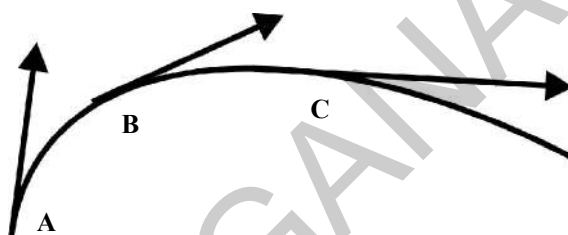

Fig-15: Motion diagram

- At which point is the speed maximum?
- Does the object in motion possess acceleration or not?

We distinguish speed and velocity for this reason and define 'acceleration' as the rate at which velocity changes, there by encompassing changes both in speed and direction.

Acceleration is also a vector and is directed along the direction of change in velocity.

The SI unit of acceleration is m/s^2



Think and discuss

- What is the acceleration of a race car that moves at constant velocity of 300 km/h ?
- Which has the greater acceleration, an airplane, that goes from 1000 km/h to 1005 km/h in 10s or a skateboard that goes from zero to 5km/h in 1 second?

- What is the deceleration of a vehicle moving in a straight line that changes its velocity from 100 km/h to a dead stop in 10s?
- Correct your friend who says “Acceleration gives an idea of how fast the position changes.”

2.8 Equations of uniform accelerated motion

Consider the motion of object along straight line with constant acceleration. (Uniform acceleration).

Then,

$$\text{Acceleration} = \frac{\text{Change in velocity}}{\text{Time taken}}$$

$$a = \frac{\Delta v}{\Delta t} = \text{constant}$$

'Δ' - denotes changes

If the acceleration of an object in motion is constant, then the motion is called uniform acceleration motion.

Let u be the velocity at the time $t = 0$ and v be the velocity at the time t and let s be the displacement covered by the body during time “ t ” as shown in fig.- 16.

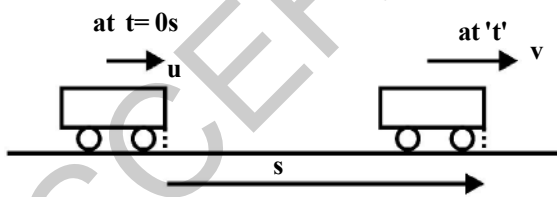

Fig-16

From the definition of uniform acceleration,

$$a = \frac{v - u}{t}$$

$$\text{Acceleration, } at = v - u$$

$$u + at = v \quad \dots\dots\dots (1)$$

Since the acceleration of the body is constant.

$$\text{Average velocity} = \frac{v + u}{2}$$

But we know

$$\text{Average velocity} = \frac{\text{Displacement}}{\text{Time taken}}$$

$$\frac{v + u}{2} = \frac{s}{t} \quad \dots\dots\dots (2)$$

From here onwards we manipulate the equations (1) and (2).

Put $v = u + at$ in equation (2), we have

$$\frac{u + at + u}{2} = \frac{s}{t}$$

$$\frac{2u + at}{2} = \frac{s}{t}$$

$$ut + \frac{1}{2} a t^2 = s \quad \dots\dots\dots (3)$$

From equation $v = u + at$, we get

$$t = \frac{v - u}{a}$$

Substitute the value of 't' in equation (2), we have

$$\left(\frac{v + u}{2}\right)\left(\frac{v - u}{a}\right) = s$$

$$v^2 - u^2 = 2as \quad \dots\dots\dots (4)$$

The equations of uniform accelerated motion are,

$$v = u + at$$

$$s = ut + \frac{1}{2} at^2$$

$$v^2 - u^2 = 2as$$

NOTE:

1. If the speed of an object increases, the direction of velocity and acceleration are one and the same.

2. If the speed of an object decreases, the direction of velocity and acceleration are in opposite directions. In such a case, at a certain instant the speed becomes zero.

3. If there exists an acceleration of a body at a point where its speed becomes zero for an instant; then the body 'returns' in the direction of acceleration and moves continuously. (like in the case of stone thrown vertically up into the air.)

2.9 Sign Convention Rules

These rules help to signify the direction of displacement (s), velocity (v) and acceleration (a)

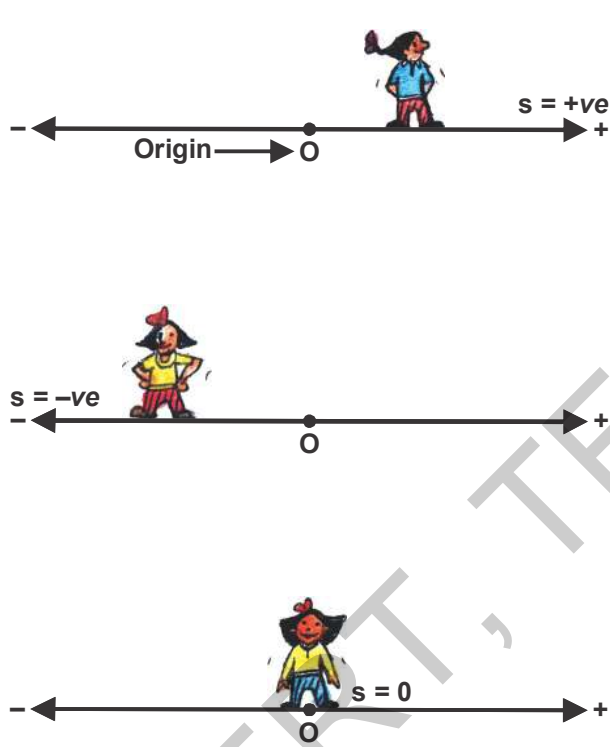

Fig-17(a)

Sign of displacement depends on position of particle

- Choose the origin on a straight line. The quantities measured to the right are taken as positive and they measured to the left are taken as negative.
- Expressing the displacement with proper sign, is important. Displacement is positive while measured along the positive direction and is negative while measured along the negative direction.

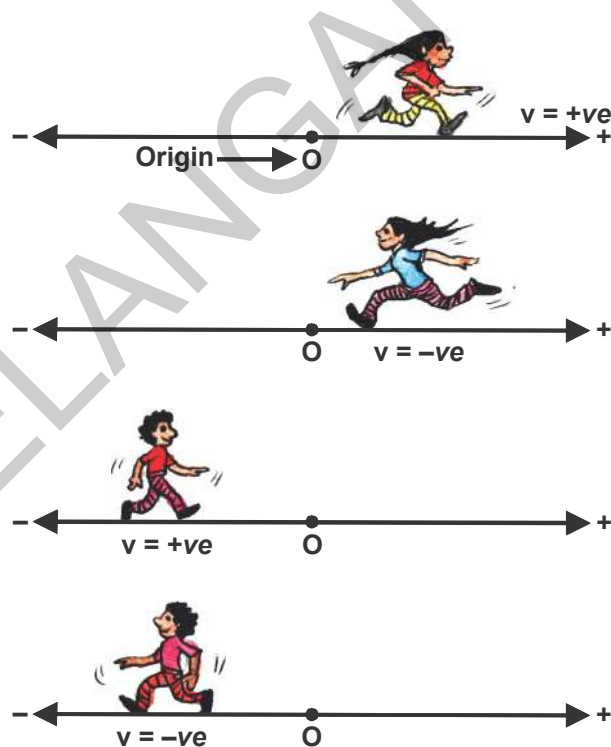

Fig-17(b)

Sign of velocity is independent of position, depends on the direction of motion



Lab Activity

Aim

- To find the acceleration and velocity of an object moving on an inclined track.

Materials required

Glass marbles, book, digital clock, long plastic tubes and steel plate.

Procedure

Take a long plastic tube of length nearly 200cm and cut it in half along the length of the tube. Use these tube parts as tracks. Mark the readings in cm along the track. Place the one end of the tube on a book and the other end on the floor, as shown in fig.-18. Keep a steel plate on the floor at the bottom of the track. Consider the reading at the bottom of the track to be zero.

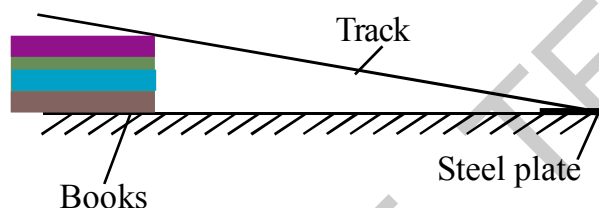

Fig-18

Take a marble having adequate size to travel in the track freely. Now release the marble freely from a certain distance say 40cm. Start the digital clock when the marble is released. It moves down on the track and strikes the steel plate. Stop the digital clock when a sound is produced. Repeat the same experiment for the same distance 2 to 3 times and note the values of times in table-4.

Table-4

Distance, S (cm)	Time t (s)			Average time t	$2S/t^2$
	t_1	t_2	t_3		

Repeat the same experiment for various distances.

Find average time and $2S/t^2$ for every trail. Will it be constant and equal to acceleration? Why?

Draw distance vs time (S-t) graph for the values in the table.

Do the same experiment for various slopes of the track and find accelerations in each case.

- Is there any relation between the slope and acceleration?
- What do you notice from the distance time graphs for various slopes?

Do the same experiment with a small iron block. Find the acceleration and draw the S-t graph.

Give your explanation for various accelerations related to slopes.

The values found in this experiment are approximate.

Example 1

A car is moving with the initial velocity 15 m/s. Car stopped after 5s by application of breaks. Find the retardation (Deceleration).

Solution

$$\begin{aligned}t &= 5 \text{ s} \\v &= 0 \text{ m/s} \\u &= 15 \text{ m/s} \\a &= ?\end{aligned}$$

Substituting the values in the following equation.

$$\begin{aligned}v &= u + at \\0 &= 15 + (a \times 5) \\a &= \frac{-15}{5} \\a &= -3 \text{ m/s}^2\end{aligned}$$

Example 2

A bus is moving with the initial velocity of 'u' m/s. After applying the breaks, its retardation is 0.5 m/s^2 and it stopped after 12s. Find the initial velocity (u) and distance travel by the bus after applying the breaks.

Solution

$$\begin{aligned}a &= -0.5 \text{ m/s}^2 \\v &= 0 \text{ m/s} \\t &= 12 \text{ s} \\u &= ? \\v &= u + at \\0 &= u + (-0.5 \times 12) \\0 &= u - 6 \\u &= 6 \text{ m/s}\end{aligned}$$

Initial velocity of the bus 6 m/s.

$$\begin{aligned}s &= ut + \frac{1}{2}at^2 \\&= (12 \times 6) + \frac{1}{2}(-0.5 \times 12^2) \\&= 72 - \frac{1}{2}(72) \\&= 36 \text{ m}\end{aligned}$$

Bus has stopped 36 m distance after applying the break.

Example 3

At a distance $L = 400 \text{ m}$ away from the signal light, brakes are applied to a locomotive moving with a velocity, $u = 54 \text{ km/h}$. Determine the position of rest of the locomotive relative to the signal light after 1 min of the application of the brakes if its acceleration $a = -0.3 \text{ m/s}^2$

Solution

Since the locomotive moves with a constant deceleration after the application of brakes, it will come to rest in 't' sec .

We know ,

$$v = u + at$$

Here $u = 54 \text{ km/h} = 54 \times \frac{5}{18} = 15 \text{ m/s}$

Let $v = 0$ at time 't' and given

$$a = -0.3 \text{ m/s}^2$$

From $v = u + at$ we get $t = \frac{v - u}{a}$

$$\text{We get, } t = \frac{-15}{-0.3} = 50 \text{ s}$$

During which it will cover a distance

$$\begin{aligned}
 s &= -\frac{u^2}{2a} \\
 &= -\frac{15^2}{2 \times (-0.3)} \\
 &= \frac{225}{0.6} \\
 &= 375 \text{ m}
 \end{aligned}$$

Thus in 1 minute after the application of brakes the locomotive will be at a distance $l = L - s = 400 - 375 = 25$ m from the signal light.

Example 4

What is the speed of the body moving with uniform acceleration at the midpoint of two points on a straight line, where the speeds are u and v respectively?

Solution

Let ' a ' be the constant acceleration and s be the distance between the two points,

From equation of motion

$$v^2 - u^2 = 2as \dots\dots\dots (1)$$

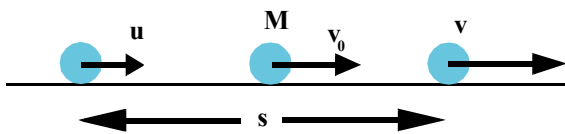

Fig-19

Let v_0 be the speed of the body at midpoint 'M' of the given points.

Applying the same equation used above, we get

$$v_0^2 - u^2 = 2a \frac{s}{2}$$

From (1), we get

$$v_0^2 - u^2 = \frac{v^2 - u^2}{2}$$

$$v_0^2 = \frac{v^2 - u^2}{2} + u^2$$

$$v_0^2 = \frac{v^2 - u^2 + 2u^2}{2}$$

$$v_0 = \sqrt{\frac{v^2 + u^2}{2}}$$

Example 5

A car travels from rest with a constant acceleration ' a ' for ' t ' seconds. What is the average speed of the car for its journey if the car moves along a straight road?

Solution

The car starts from rest, so $u = 0$

The distance covered in time t

$$s = \frac{1}{2}at^2$$

$$\text{Average speed} = \frac{\text{Total distance}}{\text{Time taken}}$$

$$v = \frac{\left(\frac{at^2}{2}\right)}{t}$$

$$= \frac{at}{2}$$



Key words

Relative, distance, displacement, average speed, average velocity, instantaneous speed (speed), velocity, uniform motion, acceleration, uniform acceleration, rectilinear motion, vectors, scalars.



What we have learnt

- Motion is relative. Motion of an object depends on the observer.
- Distance is the path length traversed and displacement is the shortest distance in a specified direction.
- Average speed is distance covered per unit time and average velocity is displacement in a specified direction per unit time.
- Speed at an instant is instantaneous speed which gives the idea of how fast the position of the body changes.
- Velocity is speed in specified direction.
- The motion is uniform when the velocity is constant.
- A body has acceleration when the velocity of the body changes.
- Acceleration is the rate of change of velocity.
- The motion is said to be uniform accelerated motion if acceleration is constant.
- The equations of uniform accelerated motion are given by

$$v = u + at$$

$$s = ut + \frac{1}{2}at^2$$

$$v^2 - u^2 = 2as$$



Improve your learning



I. Reflections on concepts

1. Distinguish between speed and velocity. (AS₁)
2. Briefly explain about constant acceleration.
3. How can you say that a body is in motion? Is it a common property? (AS₁)
4. Are average speed and average velocity same? If not explain why? (AS₁)
5. How do you measure instantaneous speed? (AS₁)
6. Explain acceleration with an example. (AS₁)

II. Application of concepts

1. In the given figure distance vs time graphs showing motion of two cars A and B are given. Which car moves fast? (AS₁)

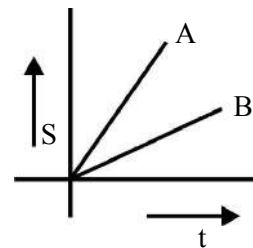

2. A train of length 50m is moving with a constant speed of 10m/s. Calculate the time taken by the train to cross an electric pole and a bridge of length 250 m. (5s , 30s) (AS₁)
3. Draw the distance vs time graph when the speed of a body increases uniformly. (AS₅)
4. Draw the distance – time graph when its speed decreases uniformly.(AS₅)
5. What is the average speed of a Cheetah that sprints 100m in 4sec. ? What if it sprints 50m in 2sec? (25 m/s)(AS₇)
6. A car travels at a speed of 80 km/h during the first half of its running time and at 40 km/h during the other half. Find the average speed of the car. (60 km/h) (AS₇)
7. A particle covers 10m in first 5s and 10m in next 3s. Assuming constant acceleration. Find initial speed, acceleration and distance covered in next 2s. (AS₇)
(7/6 m/s, 1/3 m /s², 8.33m)

III. Higher Order Thinking questions

1. When the velocity is constant, can the average velocity over any time interval differ from instantaneous velocity at any instant? If so, give an example; if not explain why. (AS₂)
2. You may have heard the story of the race between the rabbit and tortoise. They started from same point simultaneously with constant speeds. During the journey, rabbit took rest somewhere along the way for a while. But the tortoise moved steadily with lesser speed and reached the finishing point before rabbit. Rabbit wokeup and ran, but rabbit realized that the tortoise had won the race. Draw distance vs time graph for this story. (AS₅)



We observe the changes in motion of many objects around us. We discussed the concepts of velocity and acceleration in the chapter 'Motion'.

Philosophers of the ancient world were very much interested in the study of motion. One question always popping up in their mind was, what is the natural state of an object if left to itself? Our commonsense tells that every moving object on earth if it is left free for some time, gradually comes to rest by itself. What happens if you stop peddling your bicycle? It slows down gradually and finally stops.

We wonder to know that Aristotle, the great philosopher of that time also concluded that the natural state of an earthly object is to be at rest. He thought that the object at rest requires no explanation as any moving body naturally comes to rest.

Galileo Galilee stated that an object in motion will remain in same motion as long as no external force is applied on it.

Galileo came up with two thoughtful experiments. He did his experiments on inclined planes with smooth surfaces and observed that the smoother the surface, the farther the ball travelled. He extended this argument and concluded that if the surface was perfectly smooth, the ball will travel indefinitely, until encountered by another object. (In real world such a surface of course does not exist).

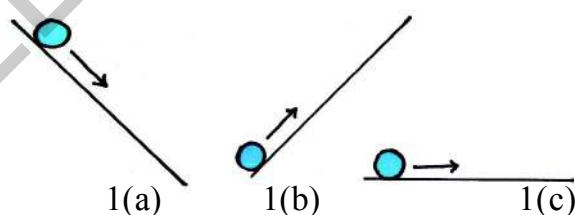

Fig-1: (a) downward motion (b) upward motion (c) motion on a plane surface

As shown in fig.- 1 (a) he observed that when a marble rolls down a slope, it picks up speed due to the force of gravity of the earth.

In fig.- 1 (b) when the object rolls up an inclined plane, its speed decreases. Now let us assume that a marble is moving on a level surface as shown in fig.- 1(c) it has no reason to speed up or slow down. So it will continue to move with constant velocity.

By this experiment, Galileo came to a conclusion which was in contrast to Aristotle's belief that the natural state of an object is 'rest'.

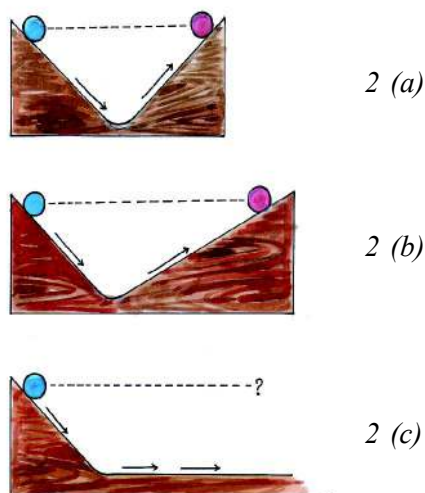

Fig-2: (a) (b) motion along inclined planes with different slopes. (c) Motion from inclined surface to plane surface

Galileo observed that, as shown in fig.- 2 (a), the marble released from its initial height rolled down due to the force of gravity and then moves up the slope until it reached its initial height. Then he reduced the angle of the upward slope and did the same experiment as in fig.- 2 (b). The marble rolled up the same height, but it had to go farther in this instance. That means the distance travelled by it is greater. He made his observation by further reduction in the angle of the upward slope, he got the same results. To reach the same height the ball had to go farther each time.

Then a question arose in his mind, "How far must it have to move to reach the same height if it has no slope to go up"? Since it has no slope to go up as shown in fig.- 2(c), obviously it should keep on

moving forever along the level surface at constant velocity. He concluded that the natural state of a moving object, if it is free of external influences, is uniform motion. What do you think of these experiments? Is any external force required to stop a moving object? From this experiment we can say that an object will remain in uniform motion unless a force acts on it.

Galileo imagined a world where there is no friction. But as we learnt in class VIII this is not possible in reality because friction, which affects the motion of an object plays an important role in our lives. For example, if there were no friction we would not have been able to walk on ground, we would not have been able to stop a fast moving car etc. It is very difficult to perform many physical activities without friction. Built upon ideas primarily developed by Aristotle and Galileo, Sir Isaac Newton proposed his three fundamental laws which explain the connection between force and a change in motion. These three laws are popularly known as Newton's laws of motion.

3.1 First law of motion

The first law of motion can be stated as follows: "Every object will remain at rest or in a state of uniform motion unless compelled to change its state by the action of a net force".

Newton's first law explains what happens to an object when no net force acts on it.

It either remains at rest or moves in a straight line with constant speed (that is

uniform motion). Let's discuss.



Do you know?

Galileo Galilei was born on 15 February 1564 in Pisa, Italy. Galileo has been called the “father of modern science”.

In 1589, in his series of essays, he presented his theories about falling objects using an inclined plane to slow down the rate of descent.

Galileo was also a remarkable craftsman. He developed a series of telescopes whose optical performance was much better than that of other telescopes available during those days.

Around 1640, he designed the first pendulum clock. In his book ‘Starry Messenger’ on his astronomical discoveries, Galileo claimed to have seen mountains on the moon, the Milky Way made up of tiny stars, and four small bodies orbiting Jupiter. In his books ‘Discourse on Floating Bodies’ and ‘Letters on the Sunspots’, he disclosed his observations of sunspots.

Using his own telescopes and through his observations on Saturn and Venus, Galileo argued that all the planets must orbit the Sun and not the earth, contrary to what was believed at that time.

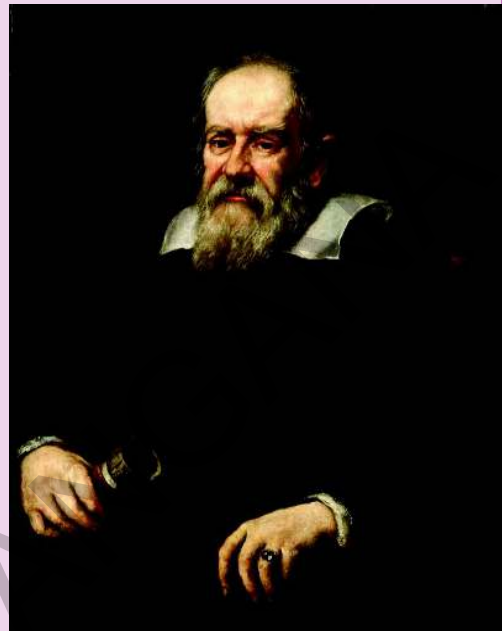

Activity-1

Observing the motion of a coin kept on thick paper

Take a thick paper. keep it on a glass tumbler. Now take a coin and keep it on the centre of the paper. As shown in fig.- 3. Push the paper with your finger as fast as you can.

- What do you observe?
- What happens to the coin?



Fig-3: Fast pushing of thick paper kept on a glass tumbler

Activity-2

Observing the motion of the coins hit by a striker

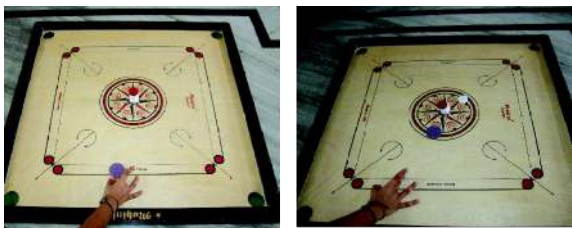

Fig-4: Hitting the stack of coins with a striker

Make a stack of carrom coins on the carrom board. Give a sharp hit at the bottom of the stack with striker. You can find that the bottom coin will be removed from the stack, and the others in the stack will slide down as shown in fig. - 4.

- What are your observations from the above activities?
- Why does the coin fall inside the glass tumbler?
- Why does the stack of carrom coins fall down vertically?

To understand this, we have to discuss some more examples which we face in our daily life.

For example when the bus which is at rest begins to move suddenly, the person standing in the bus falls backward because of static inertia of the body. The object at rest will try to remain at rest. until we apply an external force there will be no change in the position of the object. This is known as **static inertia**.

Similarly when you are travelling in a bus, the sudden stop of the bus makes you fall forward, due to dynamic inertia of the body.

The body which is in motion always tries to move in same direction until some net force act on it. This property is known as **dynamic inertia**.

With our day to day experiences, we all know that we must exert some force on an object to keep it moving. As far as the object is concerned, the force applied by us is just one of the several forces acting on it. The other forces might be friction, air resistance or gravity. Thus it is clear that it is the "net force" which determines the change in motion of an object.

Let us consider a football placed at rest on the ground. The law of inertia tells us that the football will remain in the same state unless something moves it.

If you kick the ball, it will fly in the direction you kicked, with certain speed, until a force slows it down or stops it. If the ball goes high, the force of gravity slows it down. If the ball rolls on the ground, the force of friction makes the ball slow down and stop.

If the net force acting on an object is zero, the object which is at rest remains at rest or if the object is already moving with a certain velocity it continues to move with the same velocity. Thus we can represent the first law of motion as:

If $F_{\text{net}} = 0$, then the velocity of an object is either zero or constant.

Thus when the net force acting on a body is zero, we say that the body is in equilibrium. Newton's first Law of motion is also known as the Law of Inertia.

3.2 Inertia and mass

We have learnt that inertia is the property of an object that resists changes in its state of motion. All objects have this tendency.

- Do all the bodies have the same inertia?
- What factors can decide the inertia of a body?

Which is easy for you, to push a bicycle or a car? You can observe that it is difficult to push the car. We say car has greater inertia than the bicycle. Why does the car possess more inertia than a bicycle?

Inertia is a property of matter that resists changes in its state of motion or rest. It depends on the mass of the object. The car has more inertia than a bicycle because of its mass.

Mass of an object is considered as the measure of inertia. We know that SI unit of mass is 'kg'.

Activity-3

Pushing two wooden blocks with same force

Take two rectangular wooden blocks with different masses and place them on a straight line drawn on a floor as shown in fig.--5. Give the same push at the same time to both the blocks with the help of a wooden scale.

- What do you find?
- Which one goes farther? Why?
- Which block accelerates more?

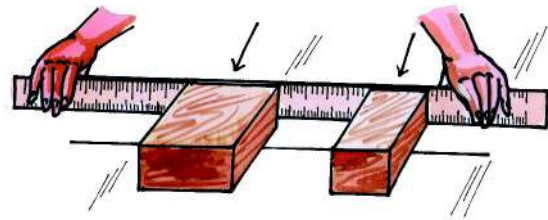

Fig-5: pushing wooden boxes with same force

Through your observations you can tell that the greater the mass of an object, the more it resists the changes in its state of motion.

From the above examples, we can conclude that some objects have more inertia than others. Mass is a property of an object that specifies how much inertia the object has.



Think and discuss

- You may have seen the trick where a table cloth is jerked from a table, leaving the dishes that were on the cloth nearly in their original positions.
 - ✓ What do you need to perform this successfully?
 - ✓ Which cloth should we use? Is it cloth made of thick cotton or thin silk?
 - ✓ Should the dishes possess large mass or small mass?
 - ✓ Is it better to pull the cloth with a large force or pull it with a gentle and steady force?
- What is the velocity of a small object that has separated from a rocket moving in free space with velocity 10km/s?

Example 1

A body of mass 'm' is kept on the horizontal floor and it is pushed in the horizontal direction with a force of 10N continuously, so that it moves steadily.

- Draw FBD (a diagram showing all the forces acting on the body at a point of time)
- What is the value of friction?

Solution

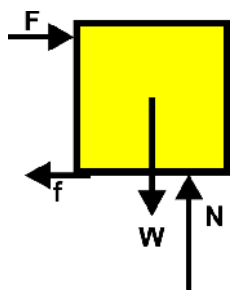

Fig-6: Free body diagram

Given that the body is moving steadily, Hence the net force on the body is zero both in horizontal and vertical directions.

Forces acting on it along horizontal direction are force of friction (f), force of push (F)

$$\begin{aligned} \text{We know that } F_{\text{net } x} &= 0 \\ F + (-f) &= 0 \\ F &= f \end{aligned}$$

Hence the value of force of friction is 10N.

3.3 Second law of motion

Newton's second law explains what happens to an object when non-zero net force acts on it.

Place a ball on the verandah and push it gently. The ball accelerates from rest.

Thus, we can say that force is an action which produces acceleration.

A non zero net force acting on a body disturbs the state of equilibrium.

Now we are going to discuss how the acceleration of an object depends on the force applied on it and how we measure a force.

3.3.1 Linear momentum

Let us recall our observations from our everyday life. If a badminton ball and a cricket ball hit you with same speed, which one hurts you more? A small bullet fired from gun damages the wall, only due to its high speed. We all know that a heavy truck causes more damage than a bicycle if both hit a wall. These can be explained by a concept called 'momentum' which is usually denoted by the symbol 'p'.

From the above examples, we can say that the momentum depends on two factors: one is mass of an object and the other is its velocity. Newton used the phrase "mass in motion" to represent the meaning of momentum. The momentum (p) of a body is simply defined as the product of its mass (m) and its velocity (v) : i.e.

$$\text{Momentum} = (\text{mass}) \times (\text{velocity})$$

$$p = mv$$

It can be stated as mass in motion. As all objects have mass, if an object is in motion, then it acquires momentum.

Momentum is a vector because velocity is a vector. Hence, the direction of momentum is in the direction of velocity.

The SI unit of momentum is kg – m/s or N-s

Activity-4

Net force acceleration

Gently push a block of ice on a smooth surface and observe how the object speeds up, in other words how it accelerates. Now increase the net force and observe change in its speed.

- Is the acceleration increased?

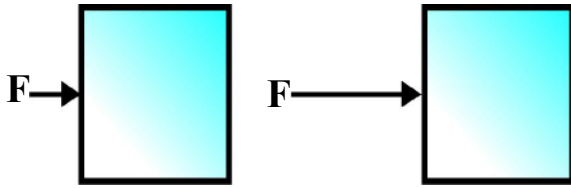

Fig-7: Different forces applied on same object

Activity-5

Mass acceleration

Apply a force on an ice block. It undergoes some acceleration.

Now take a block of ice with greater mass, but apply almost the same force on this ice block and observe the acceleration.

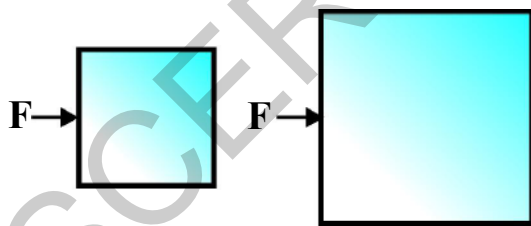

Fig-8: Same forces applied on objects of different masses

In both the cases, the object accelerates. But we can observe in the second case, it does not speed up as quickly as before.

- From the above examples what have you noticed?

The larger the net force the greater the acceleration, if the mass of the body is constant, and also larger the mass lesser the acceleration, if a constant net force is applied.

According to Newton's 'Principia' second law states that the rate of change of momentum of an object is proportional to the net force applied on the object, in the direction of net force.

Thus net force $F_{net} \propto$ change in momentum / time

$$\text{Net force} \propto \frac{\text{Change in momentum}}{\text{Time}}$$

$$F_{net} \propto \frac{\Delta p}{\Delta t}$$

Δp is the change in momentum of a particle or a system of particles brought about by the net force in a time interval Δt .

When the symbol of proportionality is removed, a constant is inserted in the equation.

$$F_{net} = k \frac{\Delta p}{\Delta t} \quad (k \text{ is constant})$$

The SI units of momentum and time are 'kg- m/s' and 's' respectively. The unit of force is so chosen that the value of constant 'k' becomes 1. So that,

$$F_{net} = \frac{\Delta p}{\Delta t}$$

We know $p = mv$

so that,

$$\Delta p = \Delta(mv)$$

If the mass of the body is constant during its motion then,

$$\Delta p = m\Delta v$$

Now we have,

$$F_{\text{net}} = m \frac{\Delta v}{\Delta t}$$

We know that $\frac{\Delta v}{\Delta t} = a$, is called uniform acceleration.

$$\text{Then } F_{\text{net}} = ma$$

The above formula says that the net force produces acceleration in a body in the direction of force.

SI units of force are kg.m/s^2 . This unit has been named as Newton (N) and

$$1\text{N} = 1\text{kg.m/s}^2.$$

Note:

- $F_{\text{net}} = \frac{\Delta p}{\Delta t}$ is a universal formula that can be applied for any system whereas $F_{\text{net}} = ma$ can be applied only for a system with constant mass.
- To solve problems by using Newton's second law, the weight of the body is taken as 'mg' vertically down. (You learn more about this in the chapter 'Gravitation')

Example 2

Atwood used the system to prove Newton's laws of motion.

Atwood machine

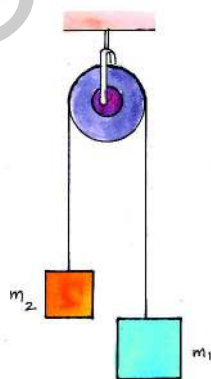

Fig-9

Atwood machine consists of two loads of masses m_1 and m_2 attached to the ends of a limp of inextensible string as shown in the fig.- 9. The string runs over a pulley. Find the acceleration of each load and tension in the string ($m_1 > m_2$).

Solution

From fig.- 10 we know that tension of string always tries to pull the bodies up.

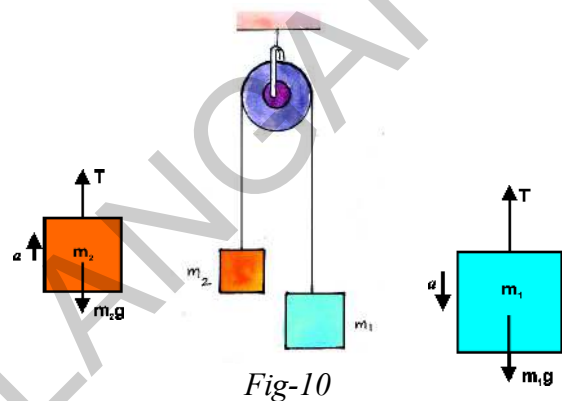

Fig-10

From the FBD of the mass m_1 , there exist two forces on the load of mass m_1 , one is tension of the string acting in upward direction and weight of the load (m_1g) acting in downward direction.

The net force on m_1

$$F_{\text{net}} = m_1 a$$

$$\Rightarrow m_1 g - T = m_1 a \text{ ----- (1)}$$

$$(\because m_1 g > T)$$

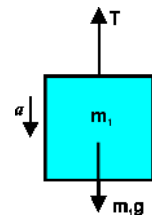

Thus the net force (F_{net}) acting on mass m_1 produces an acceleration 'a' in it.

When m_1 moves down, m_2 moves up. So the magnitudes of acceleration are same.

From the FBD of mass m_2

$$F_{\text{net}} = T - m_2 g = m_2 a \text{ ----- (2)}$$

$$(\because T > m_2 g)$$

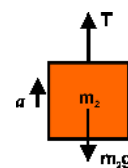

Solving (1) and (2) equations, we get

$$a = \frac{(m_1 - m_2)g}{m_1 + m_2}$$

$$T = \frac{2m_1m_2g}{m_1 + m_2}$$



Think and discuss

- Observe the Fig- 11



Fig- 11

What is the upper limit of weight that a strong man of mass 80kg can lift as shown in figure 11 ?

- What is the momentum of a ceiling fan when it is rotating?
- Is it possible to move in a curved path in the absence of a net force?

3.4 Third law of motion

Activity- 6

Pulling two spring balances

Let's take two spring balances of equal calibrations. Connect the two spring balances as shown in fig.- 12. Pull the spring balances in opposite directions as shown in fig.- 12.

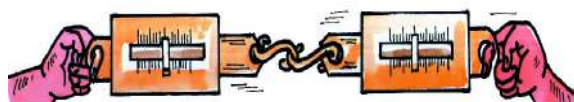

Fig-12: Forces applied in opposite direction

- What do you notice from the readings in the spring balances?
- Are the readings of two spring balances the same?
- Are we able to make the spring balances show different readings by pulling them simultaneously in opposite directions? Why not?

According to third law of motion, when an object exerts a force on an other object, the second object also exerts a force on the first one which is equal in magnitude but opposite in direction.

The two opposing forces are known as action and reaction pair. Newton's third law explains what happens when one object exerts a force on another object.

If you are walking on the ground, at each step, you know that your feet exert some force on the ground. Are you thinking that the ground also exerts some force in the opposite direction on you?

Is it not surprising to hear that when you push a wall then the wall pushes you back!

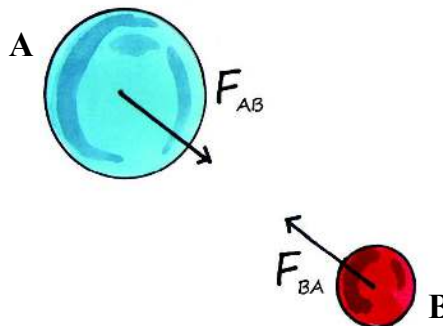

Fig-13: Action and reaction forces

If two objects interact, the force F_{BA} exerted by the object 'A' on the object 'B' is equal in magnitude and opposite in direction to the force F_{AB} exerted by object 'B' on the object 'A'.

$$F_{AB} = -F_{BA}$$

The negative sign indicates that the reaction force is acting in a direction opposite to that of action force. This states that no single isolated force exists.

Newton's first and second laws of motion apply to a single body, whereas Newton's third law of motion applies to an interaction between the two bodies. Note that the two forces in Newton's third law never act on the same body. The action-reaction pair in Newton's third law always represents forces acting on two different bodies simultaneously.

Let us consider the following examples.

When birds fly, they push the air downwards with their wings, and the air pushes back the bird in opposite upward direction. Thus the force applied by the wings of bird on air and an opposite force applied by the air on wings are equal in magnitude and opposite in direction.

When a fish swims in water, the fish pushes the water back and the water pushes the fish with equal force but in opposite direction. The force applied by the water makes the fish to move forward.

A rocket accelerates by expelling gas at high velocity. The reaction force of the gas on the rocket accelerates the rocket in

a direction opposite to the expelled gases. It is shown in fig.-14



Fig-14 : Motion of rocket

- Does the rocket exert a force on the gas expelled from it?

Activity-7

Balloon rocket

Inflate a balloon and press its neck with fingers to prevent air escaping from it.

Pass a thread through a straw and tape the balloon on the straw as shown in the fig.-15.

Hold one end of the thread and ask your friend to hold the other end of the thread. Now remove your fingers from the balloon's neck so as to release the air from the balloon.

- What happens now ?

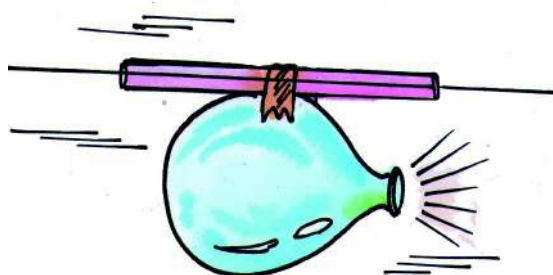

Fig-15: Balloon rocket

Inflate a balloon and tie its neck. The air within the balloon exerts force on the walls of the balloon equally in all the directions as shown in fig.-.15

This is balanced by the elastic forces of the balloon.

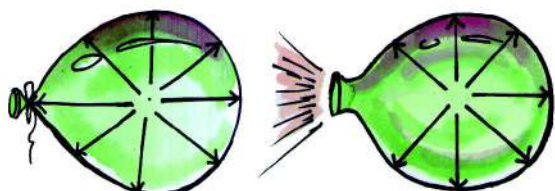

Fig-16: The forces on the inside wall of a balloon

When you release the neck of the balloon to allow air to escape from the balloon, what happens? The balloon moves in a direction opposite to that of escaping air. The momentum of the balloon and air begins with zero, when the air escapes with some velocity, the balloon moves in the opposite direction to balance the momentum of the escaping air.

Hence Balloon will get acceleration in the direction of net force.



Lab Activity

Aim: To show the action and reaction forces acting on two different objects.

Material required: Test tube, rubber cork, Bunsen burner, retort stand, water and thread.

Procedure

- Take a test tube of good quality glass and put small amount of water in it. Place a rubber cork at its mouth to close it.
- Now suspend the test tube horizontally with the help of two strings as shown in the fig.- 17.

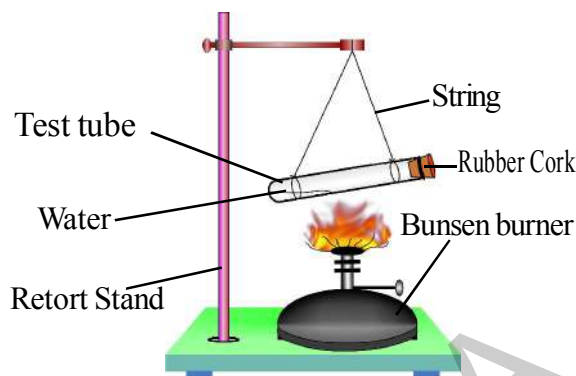

Fig-17

- Heat the test tube with a Bunsen burner until water vaporizes and cork blows out.

Observe the movement of the test tube when rubber cork blows out. Compare the directions of movement of test tube as well as rubber cork. Observe the difference in the velocity of rubber cork and that of recoiling test tube.

- What do you infer from above experiment?



Think and discuss

- The force exerted by the earth on the ball is 8N. What is the force on the earth by the ball?
- A block is placed on the horizontal surface. There are two forces acting on the block. One, the downward pull of gravity and other a normal force acting on it. Are these forces equal and opposite? Do they form action – reaction pair? Discuss with your friends.
- Why is it difficult for a fire fighter to hold a hose that ejects large amount of water at high speed?

3.5 Law of conservation of momentum

Let two objects with masses m_1 and m_2 are traveling with different velocities u_1 and u_2 respectively in the same direction along a straight line. If $u_1 > u_2$, they collide with each other and the collision lasts for time 't', which is very small. During the collision the first marble exerts a force on the second marble F_{21} and the second marble exerts a force on the first marble F_{12} . Let v_1 and v_2 be the velocities of the marbles respectively after collision.

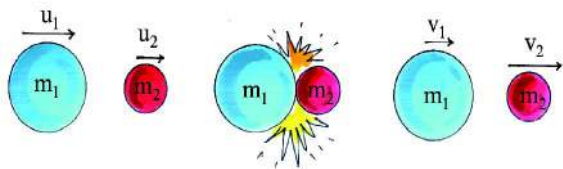

Fig-18: Conservation of momentum

What are the momenta of the marbles before and after collision? Let's know from the table.

	Marble 1	Marble 2
Momentum before collision	$m_1 u_1$	$m_2 u_2$
Momentum after collision	$m_1 v_1$	$m_2 v_2$
Change in momentum, Δp	$m_1 v_1 - m_1 u_1$	$m_2 v_2 - m_2 u_2$
Rate of change in momentum $\frac{\Delta p}{\Delta t}$	$\frac{(m_1 v_1 - m_1 u_1)}{t}$	$\frac{(m_2 v_2 - m_2 u_2)}{t}$

According to Newton's third law of motion, the force exerted by first marble

on the second is equal to the force exerted by the second marble on the first one.

$$\text{Hence } F_{12} = -F_{21}$$

Hence we get,

$$\frac{(\Delta p)_1}{t} = - \frac{(\Delta p)_2}{t}$$

$$\frac{m_1 v_1 - m_1 u_1}{t} = - \frac{(m_2 v_2 - m_2 u_2)}{t}$$

After solving this, we get

$$m_1 u_1 + m_2 u_2 = m_1 v_1 + m_2 v_2$$

$m_1 u_1 + m_2 u_2$ is the total momentum of the two marbles before collision and $m_1 v_1 + m_2 v_2$ is the total momentum of the two marbles after collision.

From the above equation, we observe that the total momentum is unchanged before and after collisions. We can say that the momentum is conserved. **Law of "Conservation of Momentum"** states that in the absence of a net external force on the system, the momentum of the system remains unchanged".

3.6 Impulse

It will be surprising if anybody says that the fall doesn't hurt, but it is the sudden stop at the end that hurts you. Is it true?

- Why does a pole vault jumper land on thick mats of foam?
- Is it safe to jump on sand rather than a cement floor? Why?

A softer and more cushioned landing surface provides a greater stopping distance because of the longer time taken to stop.

That's why the fielder pulls back his hands while catching a fast moving cricket ball. In this situation, the fielder is trying to increase the time to decrease its velocity.

Thus, the rate of change of momentum will be less so that the force of impact of the ball on hands will be reduced.

As we expressed the second law as

$$F_{\text{net}} = \frac{\Delta p}{\Delta t}$$

In order to minimize F_{net} , you have to maximize the stopping time.

$$\text{We get } F_{\text{net}} \Delta t = \Delta p$$

From the above equation we know that the product of net force and interaction time is called impulse of net force. Impulse is equivalent to the change in momentum that an object experiences during an interaction. Forces exerted over a limited time are called impulsive forces. Often the magnitude of an impulsive force is so large that its effect is appreciable, even though its duration is short. Let us observe the following activity.

Activity-8

Dropping eggs

Take two eggs and drop them from a certain height such that one egg falls on a concrete floor and another egg falls on a cushioned pillow.

- What changes do you notice in both eggs after they are dropped? Why?

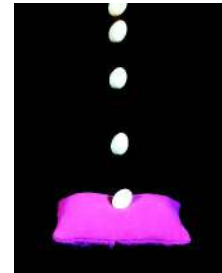

Fig-19(a)

Fig-19(b)

Fig-19: (a) fall of an egg on a concrete floor
(b) fall of an egg on a cushioned pillow.

When we drop the egg on the concrete floor, it will break, because a large force acts on the egg for the short interval of time.

$$\Delta p = F_{\text{net}2} \Delta t_1$$

When we drop the egg on a cushioned pillow, it doesn't break because a smaller force acts on the egg for longer time.

$$\Delta p = F_{\text{net}} \Delta t_2$$

Even if the Δp is the same in both the cases, the magnitude of the net force (F_{net}) acting on the egg determines whether the egg will break or not.

Why does a fielder catch a fast moving cricket ball by pulling back his arms while catching it? If he doesn't pull his hands back what would happen? The ball definitely hurts him. When he pulls back his hands he experiences a smaller force for a longer time. The ball stops only when your hands stop. This shows that the change in the momentum not only depends on the magnitude of the force but also on the time during which force is exerted on that object.



Think and discuss

- A meteorite burns in the atmosphere before it reaches the earth's surface. What happens to its momentum?

- As you throw a heavy ball upward, is there any change in the normal force on your feet?
- When a coconut falls from a tree and strikes the ground without bouncing. What happens to its momentum?
- Air bags are used in cars for safety. Why?

Example 3

A cannon of mass $m_1 = 12000$ kg located on a smooth horizontal platform fires a shell of mass $m_2 = 300$ kg in horizontal direction with a velocity $v_2 = 400$ m/s. Find the velocity of the cannon after it is shot.

Solution

Since the pressure of the powder gases in the bore of the cannon is an internal force the net external force acting on cannon during the firing is zero.

Let v_1 be the velocity of the cannon after shot. The initial momentum of system is zero.

The final momentum of the system
 $= m_1 v_1 + m_2 v_2$

From the conservation of linear momentum, We get,

$$m_1 v_1 + m_2 v_2 = 0$$

$$m_1 v_1 = - m_2 v_2$$

$$v_1 = - m_2 v_2 / m_1$$

Substituting the given values in the above equation, we get

$$v_1 = - \frac{(300\text{kg}) \times (400\text{m/s})}{12000\text{kg}}$$

$$= -10 \text{ m/s.}$$

Thus the velocity of cannon is 10m/s after the shot.

Here '-' sign indicates that the canon moves in a direction opposite to the motion of the bullet.



Key words

Laws of motion, Inertia, Mass, Linear momentum, Conservation of momentum, Impulse, Impulsive force



What we have learnt

- First Law of Motion: A body continues its state of rest or of uniform motion unless a net force acts on it.
- The natural tendency of objects to resist a change in their state of rest or of uniform motion is called inertia.
- The mass of an object is a measure of inertia. SI unit of mass is Kilogram (kg).
- Second Law of Motion: The rate of change of momentum of a body is directly proportional to the net force acting on it and it takes place in the direction of net force.

- Linear momentum of a body is the product of its mass and velocity $p = mv$.
- One 'Newton' is the force which when acting on a body of mass 1 kg, produces an acceleration of 1 m/s^2
 $1 \text{ newton (N)} = 1\text{kg} \times 1 \text{ ms}^{-2}$
- Third Law of Motion: If one object exerts a force on other object, the second object exerts a force on the first one with equal magnitude but in opposite direction.



Improve your learning



I. Reflections on Concepts

- 1) Explain the reasons for the following. (AS_1)
 - a) Why dust comes out of a carpet when it is beaten with a stick?
 - b) Luggage kept on the roof of a bus is tied with a rope.
 - c) Why a pace bowler in cricket runs from a long distance before he bowls?
- 2) Illustrate an example of each of the three laws of motion. (AS_1)
- 3) Explain the following: (AS_1)
 - a) Static Inertia
 - b) Inertia of motion
 - c) momentum
 - d) impulse
 - e) impulsive force

II. Application of Concepts

- 1) Two objects have masses 8 kg and 25 kg. Which one has more inertia? Why? (AS_1)
- 2) What is the momentum of a 6.0 kg ball bowling with a velocity of 2.2 m/s?
 (Ans: 13.2 kg m/s^2) (AS_1)
- 3) Two people push a car for 3 s with a combined net force of 200 N. (AS_1)
 - (a) Calculate the impulse provided to the car.
 - (b) If the car has a mass of 1200 kg, what will be its change in velocity?
 (Ans: (a) 600 N.s (b) 0.5 m/s)
- 4) A man of mass 30 kg uses a rope to climb which bears only 450 N. What is the maximum acceleration with which he can climb safely? (Ans: 15 m/s^2) (AS_7)

III. Higher Order Thinking questions

1. A vehicle has a mass of 1500 kg. What must be the force between the vehicle and the road if the vehicle is to be stopped with a negative acceleration of 1.7 ms^{-2} ?
 (Ans:- -2550 N in a direction opposite to that of the motion of the vehicle) (AS_7)

- Two ice skaters initially at rest, push of each other. If one skater whose mass is 60 kg has a velocity of 2 m/s. What is the velocity of other skater whose mass is 40 kg?
(Ans: 3 m/s in opposite direction) (AS₇)
- If a fly collides with the windshield of a fast-moving bus, (AS₂)
 - Is the impact force experienced, same for the fly and the bus? Why?
 - Is the same acceleration experienced by the fly and the bus? Why?



Multiple choice questions

- The scientist who said that "an object in motion will remain in same motion as long as no external force is applied" is []
 - Aristotle
 - Galileo
 - Newton
 - Dalton
- If the net force acting on an object is zero, then the body is said to be in the state of []
 - Equilibrium
 - Motion
 - Inertia of motion
 - Uniform motion
- The inertia of a body depends on []
 - Shape
 - Volume
 - Mass
 - Area
- Newton used the word 'mass in motion' to represent []
 - Linear momentum
 - Inertia of motion
 - Velocity
 - Inertia at rest
- The S.I unit of momentum is []
 - m/sec
 - Kg-m
 - k.g.m/sec
 - Kg. m/sec²



Suggested Experiments

- Conduct an experiment to prove Newton's first law of motion and write a report.
- Conduct an experiment to show the action and reaction forces acting on two different objects.



Suggested Projects

- Observe some daily life examples for Newton's first law of motion and explain the situations. Write a report on your observations.
- Write a report on the action and reaction in the systems that you have observed in your daily life which are the evident of Newton's third law of motion.



We have learnt about the reflection of light on plane surfaces in class 7 and 8. Beauty of the nature is made apparent with light. Light exhibits many interesting phenomena.

Let us try to explore a few of them.

You might have observed that a coin kept at the bottom of a vessel filled with water appears to be raised. Similarly, a lemon kept in a glass of water appears to be bigger than its size. When a thick glass slab is placed over some printed letters, the letters appear raised when viewed through the glass slab.

- What could be the reasons for the above observations?

Activity 1

Take some water in a glass tumbler. Keep a pencil in it. Look at the pencil from one side of the glass and also from the top of the glass.

- How does it look?
- Do you find any difference between the two views?

Activity 2

Go to a long wall (of length about 30 feet) facing the Sun. Go to one end of a wall and ask your friend to bring a bright metal object near the other end of the wall. When the object is a few inches from the wall it appears distorted and you will see a reflected image in the wall as though the wall were a mirror.

- Why is there an image of the object on the wall?

To answer the above questions and to give reasons for the situations mentioned we need to understand the phenomenon of refraction of light.

4.1 Refraction

Activity 3

Take a shallow vessel with opaque walls such as a mug. (A tin or a pan is suitable). Place a coin at the bottom of the vessel.

Move away from the vessel until you cannot see the coin.

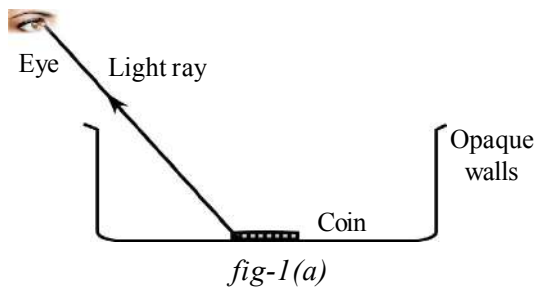

See fig.- 1(b).

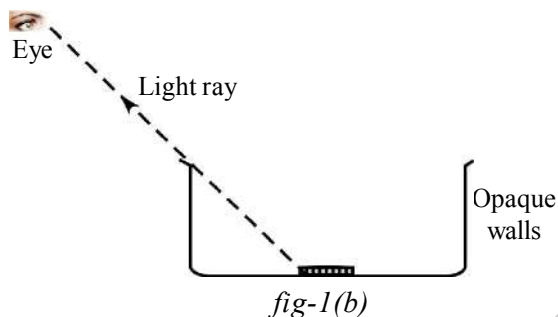

Stand there. Ask your friend to fill the vessel with water. When the vessel is filled with water the coin comes back into view. See fig.- 1(c).

- Why are you able to see the coin when the vessel is filled with water?

You know that the ray of light originating from the coin, doesn't reach your eye when the vessel is empty (see fig.-1b). Hence you couldn't see the coin. But the coin becomes visible to you after the vessel is filled with water.

- How is it possible?
- Do you think that the ray reaches your eye when the vessel is filled with water?

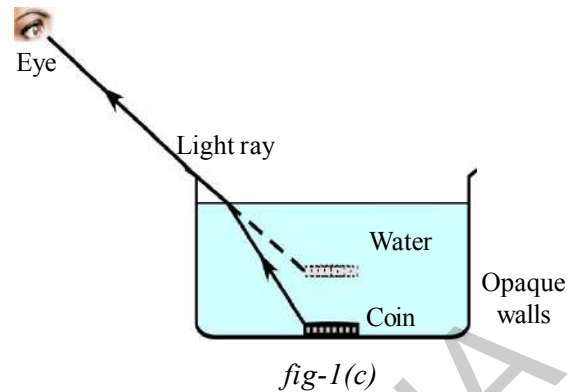

If yes, draw a ray diagram from the coin to the eye. Keep in mind that the light ray travelling in a medium takes a straight line path.

- What happens to the light ray at the interface between water and air?
- What could be the reason for this bending of the light ray in the second instance?

The above questions can be answered by Fermat's principle, the principle states that the light ray always travels between two points in a path which needs the shortest possible time to cover. Let us apply this principle to our activity.

By observing the path of the ray, it is clear that the light ray changes its direction at the interface separating the two media i.e, water and air. This path is chosen by the light ray so as to minimize time of travel between coin and eye. This is possible only if the speed of the light changes at interface of two media. Thus we can conclude that the speed of the light changes when light propagates from one medium to another medium.

“The process of changing speed at an interface when light travels from one medium to another resulting in a change in direction is called refraction of light. The process of refraction involves bending of light ray except when it is incident normally”.

Consider that light travels from medium 1 with speed v_1 to medium 2 with speed v_2 as shown in figures-2(a) and 2(b).

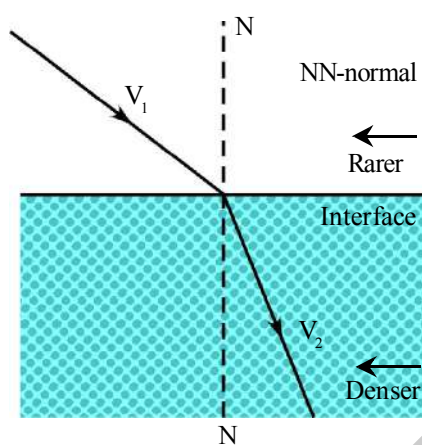

fig-2(a)

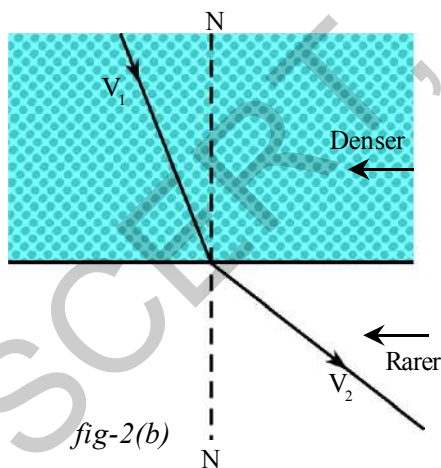

fig-2(b)

- What difference do you notice in fig 2(a) and Fig 2(b) with the respect to refracted rays?
- Is there any relation between behaviour of refracted rays and speeds of the light?

Experiments have showed that change in the direction of light is due to change in the speed of the light in the medium.

If v_2 is less than v_1 then medium 2 is said to be denser with respect to medium 1.

If v_2 is greater than v_1 then medium 2 is said to be rarer with respect to medium 1.

If light ray enters from rarer medium to denser medium then refracted ray moves towards the normal drawn at the interface of separation of two media. When it travels from denser medium to rarer medium it bends away from normal. We have seen that the ray of light deviates from its path at the interface. Draw a normal at the point of incidence as shown in fig.- (3).

Let ‘ i ’ be the angle made by incident ray with normal and ‘ r ’ be the angle made by refracted ray with the normal. These angles are called angle of incidence and angle of refraction respectively.

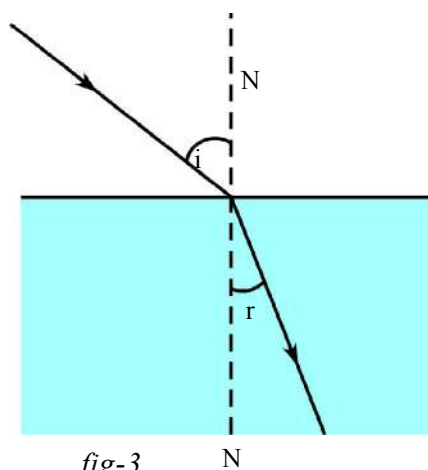

fig-3

To explain the process of refraction we need to know about a constant called refractive index which is the property of a transparent medium. Let us learn about it.

The extent of the change in direction that takes place when a light ray propagates through one medium to another medium is expressed in terms of refractive index.

4.2 Refractive index

Light travels in vacuum with a speed nearly equal to 3×10^8 m/s (denoted by letter 'c'). The speed of light is smaller than 'c' in other transparent media.

Let 'v' be the speed of light in a certain medium. Then the ratio of speed of light in vacuum to the speed of light in that medium is defined as refractive index 'n'. It is called absolute refractive index.

Absolute refractive index (n)

$$= \frac{\text{speed of light in vacuum}}{\text{speed of light in medium}}$$

$$n = \frac{c}{v} \quad \dots\dots\dots(1)$$

It is a dimensionless quantity because it is a ratio of the same physical quantities. Refractive index gives us an idea of how fast or how slow light travels in a medium. The speed of light in a medium is low when refractive index of the medium is high and vice versa. The refractive index 'n' means that the speed of light in that medium is n^{th} part of speed of light in vacuum.

For example the refractive index of glass is $\frac{3}{2}$. Then the speed of light in glass

$$\text{is } v = \frac{c}{n} = \frac{3 \times 10^8}{3/2} = 2 \times 10^8 \text{ m/s}.$$

Table:1 Refractive indices of some material media.

Material medium	Refractive index	Material medium	Refractive index
Air	1.0003	Canada balsam	1.53
Ice	1.31	Rock salt	1.54
Water	1.33	Carbon Diasulphide	1.63
Kerosene	1.44	Dense flint glass	1.65
Fused quartz	1.46	Ruby	1.71
Turpentine oil	1.47	Sapphire	1.77
Crown glass	1.52	Diamond	2.42
Benzene	1.50		

Note : From table-1, you know that an optically denser medium may not possess greater mass density. For example, kerosene with high refractive index is optically denser than water

although its mass density is less than water.

- Why do different material media possess different values of refractive Indices?

- On what factors does the refractive index of a medium depend?

Refractive index depends on the following factors.

(1) Nature of material (2) Wavelength of light used. (You will learn about this in your higher classes).

4.2.1 Relative refractive index

The refractive index of a medium with respect to another medium is defined as the ratio of speed of light in the first medium to the speed of light in the second medium. Let v_1 and v_2 be the speeds of light in the first and second media respectively. Then,

Refractive index of second medium with respect to first medium is given by

$$n_{21} = \frac{\text{speed of light in medium - 1}}{\text{speed of light in medium - 2}}$$

$$n_{21} = \frac{v_1}{v_2}$$

Dividing both numerator and denominator by c we get

$$= \frac{v_1}{v_2} = \frac{v_1/c}{v_2/c} = \frac{1/n_1}{1/n_2} = \frac{n_2}{n_1}$$

$$\Rightarrow n_{21} = \frac{n_2}{n_1} \dots\dots\dots(2)$$

This is called relative refractive Index. We define relative Refractive index as follow

Relative refractive index, $n_{21} =$

$$\frac{\text{Refractive index of second medium } (n_2)}{\text{Refractive index of first medium } (n_1)}$$



Lab Activity

Aim: Obtaining a relation between angle of incidence and angle of refraction.

Materials required: A plank, white chart, protractor, scale, small black painted plank, a semi circular glass disc of thickness nearly 2cm, pencil and laser light.

Procedure :

Take a wooden plank which is covered with white chart. Draw two perpendicular lines, passing through the middle of the paper as shown in the fig.- 4(a). Let the point of intersection be O. Mark one line as NN which is normal to the another line marked as MM. Here MM represents the line drawn along the interface of two media and NN represents the normal drawn to this line at 'O'.

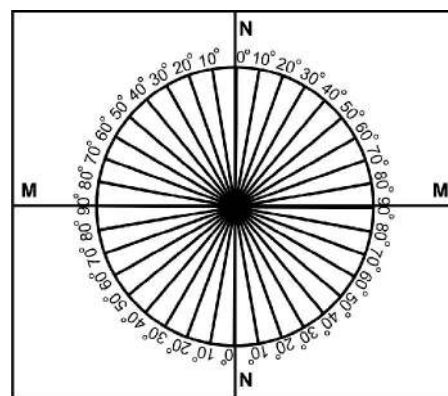

fig-4(a)

Take a protractor and place it along NN in such way that its centre coincides with O as shown in fig.- 4(a). Then mark the angles from 0° to 90° on both sides of the line NN as shown in fig.- 4(a).

Repeat the same on the other side of the line NN. The angles should be indicated on the curved line.

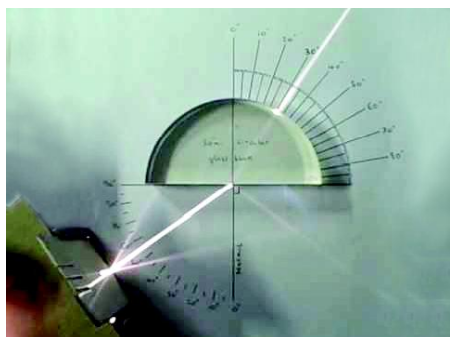

fig-4(b)

Now place a semi-circular glass disc so that its diameter coincides with the interface line (MM) and its center coincides with the point O. Point a laser light along NN in such a way that the light propagates from air to glass through the

interface at point O and observe the path of laser light coming from other side of disc as shown in fig.- 4 (b). (If you cannot observe the path of laser light put a black-coloured plank against the curved line and observe the light point and imagine the light path).

- Is there any deviation?

Send Laser light along a line which makes 15° (angle of incidence) with NN and see that it passes through point O. Measure its corresponding angle of refraction, by observing laser light coming from the other side (Circular side) of the glass slab. Note these values in table-2. Do the same for the angles of incidence such as $20^\circ, 30^\circ, 40^\circ, 50^\circ$ and 60° and note the corresponding angles of refraction.

Table 2

i	r	Sin i	Sin r	Sin i / Sin r

Find sin i, sin r for every 'i' and 'r' and evaluate sin i / sin r for every incident angle 'i'.

Note : Take the help of your teacher to find the values of sin i and sin r for each case.

Finally, we will get the ratio $\frac{\sin i}{\sin r}$ as a constant.

- Is this ratio equal to refractive index of glass? Why?

This ratio gives the value of refractive index of glass. In the above experiment you might have noticed that 'r' is less than 'i' in all cases and the refracted ray bends towards normal in each case.

- What do you conclude from these observations?

From the above experiment we can conclude that when light ray travels from a rarer medium (air) to a denser medium (glass) the value of r is less than the value of 'i' and

the refracted ray bends towards the normal.

- Can you guess what happens when light ray travels from a denser medium to a rarer medium?

Let us take up another activity to find this.

Activity 4

Take a metal disk. Use a protractor and mark angles along its edge as shown in the fig.- 5(a). Arrange two straws at the centre of the disk in such a way that they can be rotated freely about the centre of the disc.

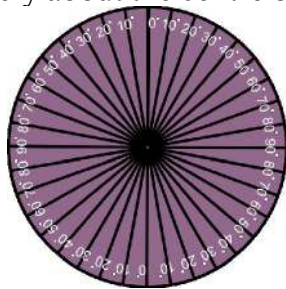

fig-5(a)

Adjust one of the straws to make an angle 10° . Immerse half of the disc vertically into the water, filled in a transparent vessel. While dipping, verify that the straw at 10° is inside the water. From the top of the vessel try to view the straw which is inside the water as shown in fig.- 5(b). Then adjust the other straw which is outside the water until both straws appear to be in a single straight line.

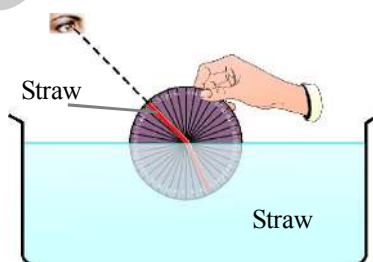

fig5(b)

Then take the disc out of the water and observe the two straws on it. You will find that they are not in a single straight line.

- Why do the straws appear to be in a straight line when we view them from the top?

Measure the angle between the normal and second straw. Draw table-2 again in your notebook and note the value. Do the same for various angles. Find the corresponding angles of refraction and note them in the table drawn. Use the data in the table and find refractive index of water. Do not take up this activity for angles of incidence greater than 48° . You will learn the reasons for this in the following sections.

You will observe that in the above activity, 'r' is greater than 'i' in all cases that means when light travels from water (denser) to air (rarer). It behaves in an opposite way to that we observed in lab activity 1.

From this activity we can generalize that when the light ray travels from denser to rarer, it bends away from the normal and $r > i$.

- Is there any relation between the angle of incidence and the angles of refraction?

The relation between angle of incidence and angle of refraction can be given by $n_1 \sin i = n_2 \sin r$.

This is called **Snell's law**

$$\Rightarrow \frac{\sin i}{\sin r} = \frac{n_2}{n_1}$$

we know $\frac{n_2}{n_1} = \frac{v_1}{v_2}$

$$\Rightarrow \frac{\sin i}{\sin r} = \frac{v_1}{v_2}$$

When light travels from one medium to another the ratio of speeds is $\frac{v_1}{v_2}$ and the ratio of refractive indices is $\frac{n_2}{n_1}$. Hence angle of incident and angle of refraction will follow $\frac{\sin i}{\sin r} = \frac{v_1}{v_2}$

Derivation of Snell's Law :

Consider the following analogy to derive it.

Let us imagine that a person has fallen out of boat and is screaming for help in the water at point B as shown in fig.- 6(a).

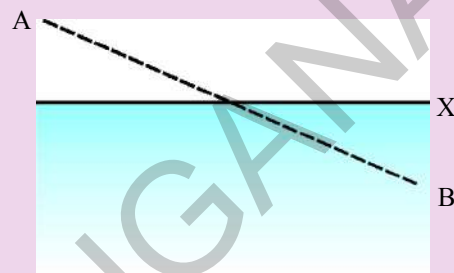

fig-6(a)

The line marked through point 'X' is the shore line. Let us assume that we are at a point 'A' on the shore and we saw the accident. In order to save the person we need to travel a certain distance on land and a certain distance in water.

We know that, we can run faster on land than we can swim in water.

- What do we do to save the person?
- Which path enables us to save the person in the shortest possible time?
- Do we go in a straight line?

By careful thought we would realize that it would be advantageous to travel a greater distance on the land in order to decrease the distance in water because we go much slower in water. For whatever speeds on land and in water, the final path that one has to follow to reach the person is ACB, and that this path takes the shortest time of all the possible paths (see fig.- 6c). If we take any other route, it will be longer.

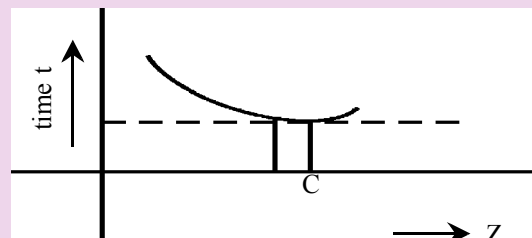
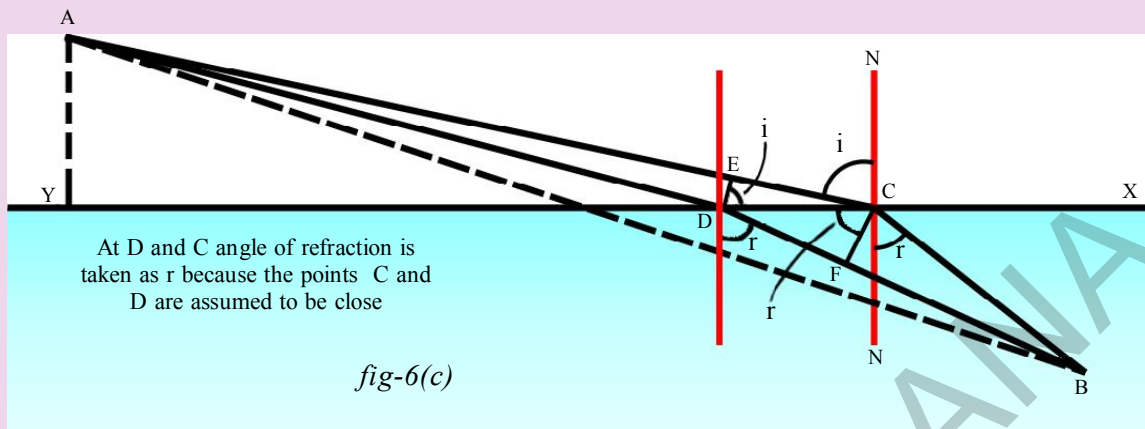

fig-6(b)

If we plot a graph for the time taken to reach the girl against the position of any point when we cross the shore line, we would get a curve something like that shown in fig.-6(b). In this graph, the distance from point Y to the points like D, C are taken as values of Z.

Where 'C', the point on shore line, corresponds to the shortest of all possible times. Let us consider a point 'D' on shore line which is very close to point 'C' such that there is essentially no change in time between path ACB and ADB.

Let us try to calculate how long it would take to go from A to B by the two paths one through point D and another through point C (see fig.- 6c).



First look at the paths on the land as shown in fig.- 6(c). If we draw a perpendicular DE; between two paths at D, we see that the path (AD) on land is shortened by the amount EC. On the other hand, in the water, by drawing a corresponding perpendicular CF we find that we have to go the extra distance DF in water.

In other words, we gain a time that is equal to go through distance EC on land but we lose the time that is equal to go extra distance DF in water. These times must be equal since we assumed there no change in time between the two paths.

Let the time taken to travel from E to C and D to F be Δt and v_1 and v_2 be the speeds of running and swimming. From fig.- 6(c) we get,

$$EC = v_1 \Delta t \text{ and } DF = v_2 \Delta t$$

$$\Rightarrow \frac{EC}{DF} = \frac{v_1}{v_2} \quad \text{—————(3)}$$

Let i and r be the angles measured between the path ACB and normal NN, perpendicular to shore line X.

- Can you find $\sin i$ and $\sin r$ from fig.- 6(c)?

Note : Sin of any acute angle in a right angled triangle can be defined as a ratio of opposite side of that angle to the Hypotenuse.

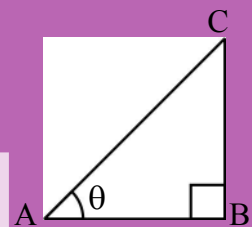
$$\sin \theta = \frac{BC}{AC}$$

From fig.- 6(c), we get;

$$\sin i = \frac{EC}{DC} \text{ and } \sin r = \frac{DF}{DC}$$

Therefore,

$$\frac{\sin i}{\sin r} = \frac{EC}{DF} \quad \text{—————(4)}$$

from equations (3) and (4), we have

$$\sin i / \sin r = v_1 / v_2 \quad \text{—————(5)}$$

Thus to save the person, one should take such a path to satisfy the above equation. We used the principle of least time to derive the above result. Hence we can apply the same for the light ray also. From (5) we get,

$$\frac{\sin i}{\sin r} = \frac{v_1}{v_2} = \frac{n_2}{n_1} \quad \left(\text{since } \frac{v_1}{v_2} = \frac{n_2}{n_1}\right)$$

$$\Rightarrow n_1 \sin i = n_2 \sin r.$$

This is called **Snell's law**.

Above experiments and activities show that refraction of light occurs according to certain laws.

Following are the laws of refraction.

1. The incident ray, the refracted ray and the normal to interface of two transparent media at the point of incidence all lie in the same plane.
2. During refraction, light follows Snell's law

$$n_1 \sin i = n_2 \sin r \quad (\text{or}) \quad \frac{\sin i}{\sin r} = \text{constant.}$$

- Is there any chance that angle of refraction is equal to 90° ? When does this happen?

Let us find out

4.3 Total Internal Reflection

Activity 5

Use the same materials as used in lab activity 1. Place the semi circular glass disc in such a way that its diameter coincides with interface line MM and its centre coincides with point 'O' as we have done in lab activity. Now send light from the curved side of the semicircular glass disc.

This means that we are making the light travel from denser medium to rarer medium. Start with angle of incidence (i) equal to 0° i.e., along the normal and look for the refracted ray on the other side of the disc.

- Where do you find the refracted ray?
- Does it deviate from its path when it enters the rarer medium?

You might have noticed that it doesn't deviate. Send laser light along angles of incidence 5° , 10° , 15° etc., and measure the angle of refraction. Tabulate the results in table-3 as shown below and note the values 'i' and 'r' in the table.

- At what angle of incidence do you notice that the refracted ray grazes the interface separating the two media (air and glass)?

Table 3

i	r

You will observe that at a certain angle of incidence the refracted ray does not come out but grazes the interface separating air and glass. Measure the angle of incidence for to this situation. This angle of incidence is known as **critical angle**.

Let us consider the light ray that travels from medium 1 with refractive index n_1 to medium 2 with refractive index n_2 . See fig.-7.

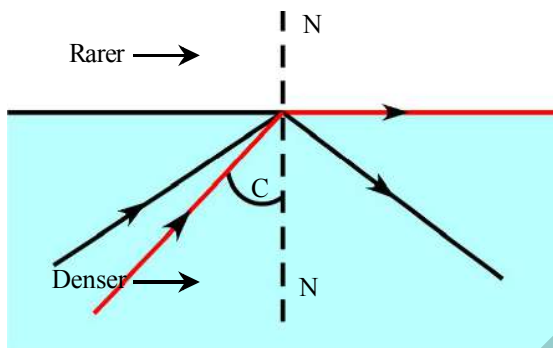

fig-7

It is already found that the angle of refraction is more than angle of incidence when a light ray travels from denser(n_1) to rarer medium (n_2).

For the angle of incidence i , let r be the angle of refraction.

From Snell's law

$$n_1 \sin i = n_2 \sin r \Rightarrow \frac{n_1}{n_2} = \frac{\sin r}{\sin i}$$

we know that, $\frac{n_1}{n_2}$ is greater than 1, so that $\sin r / \sin i$ is greater than 1. So we conclude that the angle of refraction is greater than the angle of incidence, i.e, r is greater than i .

The angle of incidence at which the light ray, travelling from denser to rarer medium, grazes the interface is called critical angle for denser medium. It is shown in fig.-7.

Let C be the critical angle. Then r becomes 90°

$$\text{we get, } \frac{n_1}{n_2} = \frac{\sin 90^\circ}{\sin c}$$

$$\Rightarrow \frac{n_1}{n_2} = \frac{1}{\sin c}$$

We get $\sin c = \frac{n_2}{n_1}$. We know that $\frac{n_1}{n_2}$ i.e., n_{12} is called *refractive index* of denser medium with respect to rarer medium

$$\sin c = \frac{1}{n_{12}}$$

- Can you find the critical angle of water using the above equation? Discuss it in your class.
- What happens to light when the angle of incidence is greater than critical angle?

When the angle of the incidence is greater than critical angle, the light ray gets reflected into the denser medium at the interface i.e., light never enters the rarer medium. This phenomenon is called *total internal reflection*. It is shown in fig.- 7.

Discuss these ideas in your class and find out the critical angle of water.

Let us see an example on total internal reflection.

Activity 6

Take a transparent glass tumbler and coin. Place the coin on a table and place glass tumbler on the coin. Observe the coin from the side of the glass.

- Can you see the coin?

Now fill the glass tumbler with water and observe the coin from the side of the glass tumbler.

- Can you see the coin?
- Explain why the coin disappears from view.

Activity 7

Take a cylindrical transparent vessel (you may use 1 L beaker). Place a coin at the bottom of the vessel. Now pour water until you get the image of the coin on the water surface (look at the surface of water from a side). See fig.- 8.

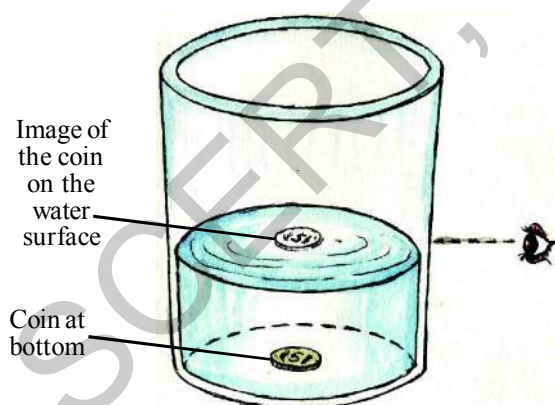

fig-8

- Can you explain why the image of the coin is formed?

There are many interesting situations around us which involve the phenomenon

of total internal reflection. One of that is a mirage which we witness while driving or while walking on a road during a hot summer day.

4.4 Mirages

Mirage is an optical illusion where it appears that water has collected on the road at a distant place but when we get there, we don't find any water.



fig-9(a)

- Do you know the reason why it appears so?

The formation of a mirage is the best example where refractive index of a medium varies throughout the medium.

During a hot summer day, air just above the road surface is very hot and the air above is less warmer. As a result density of air increases with height above road. We know that refractive index of air increases with density. Thus the refractive index of air increases with height. So, the cooler air at the top has greater refractive index than hotter air just above the road. Light travels faster through the thinner hot air than through the denser cool air above it.

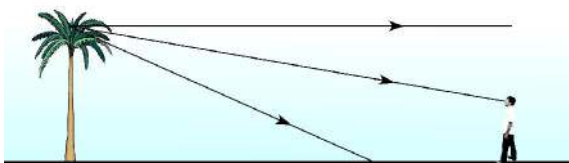
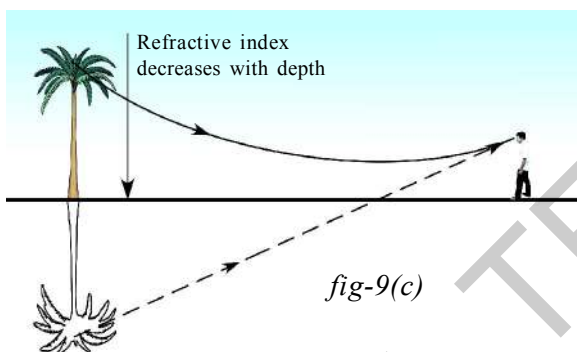

fig-9(b): The paths of light rays when there is no change in density of air

When the light from a tall object such as tree or from the sky passes through a medium just above the road, whose refractive index decreases towards ground, it suffers, refraction and takes a curved path because of total internal reflection. See fig.- 9(c).



This refracted light reaches the observer in a direction shown in Fig.--9c. This appears to the observer as if the ray is reflected from the ground. Hence we feel the illusion of water being present on road (shown in fig.-9a) which is the virtual image of the sky (mirage) and an inverted image of tree on the road (shown in fig.-9c).



Think and discuss

- Why should you see a mirage as a flowing water?
- Can you take a photo of a mirage?

4.5 Applications of total internal reflection

- Brilliance of diamonds:** Total internal reflection is the main reason for brilliance of diamonds. The critical angle of a diamond is very low (24.4°) due to higher refractive index. So if a light ray enters a diamond it is very likely to undergo multiple total internal reflection which makes the diamond shine from its multiple edges.
- Optical fibres:** Total internal reflection is the basic principle behind working of optical fibre. An optical fibre is very thin fibre made of glass (or) plastic having radius about a micrometer (10^{-6} m). A bunch of such thin fibres form a light pipe.

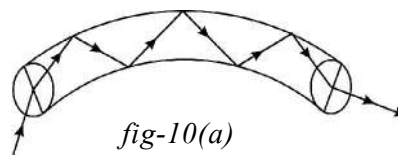

fig-10(a)

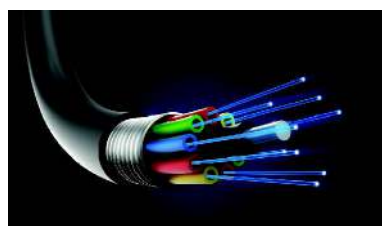

fig-10(b)

Fig.- 10(a) shows the principle of light transmission by an optical fibre. Fig.- 10(b) sketches a optical fibre cable. Because of the small radius of the fibre, light going into it makes a nearly glancing incidence on the wall. The angle of incidence is greater than the critical angle and hence total internal reflection takes place. The light is thus transmitted along the fibre.

All organs of the human body are not accessible to the naked eye of the doctor, for example intestines. The doctor inserts light pipe into the stomach through the mouth. Light is sent down through one set of fibres in the pipe. This illuminates the inside of the stomach. The light from the inside travels back through another set of fibres in the pipe and the viewer gets the image at the outer end (generally fed to the computer screen).

The other important application of fibre optics is to transmit communication signals through light pipes. For example, about 2000 telephone signals, appropriately modulated with light waves, may be simultaneously transmitted through a typical optical fibre. The clarity of the signals transmitted in this way is much better than other conventional methods.

- How does light behave when a glass slab is introduced in its path?

Let us see.

4.6 Refraction Through a Glass Slab

A thin glass slab is formed when a medium is isolated from its surroundings by two plane surfaces parallel to each other. Let us determine position and nature of the image formed when the slab is placed in front of an object. Let us do an activity.



Lab Activity

Aim: Determination of refracted ray tracking by a glass slab and lateral shift.

Material required: Drawing board, chart paper, clamps, scale, pencil, thin glass slab and pins.

Procedure:

Place a piece of chart (paper) on a drawing board. Clamp it. Place a glass slab in the middle of the paper. Draw border line along the edges of the slab by using a pencil. Remove it. You will get a figure of a rectangle. Name the vertices of the rectangle as A, B, C and D.

Draw a perpendicular at a point on the longer side (AB) of the rectangle. Again keep the slab on paper such that it coincides with the sides of the rectangle ABCD. Take two pins. Stick them on the perpendicular line to AB. Take two more pins and stick them on the other side of the slab in such a way that all pins come to view along a straight line. Remove the slab from its place. Take out the pins. Draw a straight line by using the dots formed by the pins such that it reaches first edge (AB) of the rectangle. You will get a long straight line.

- What does it mean?

The light ray that falls perpendicular to one side of the slab surface comes out with out any deviation.

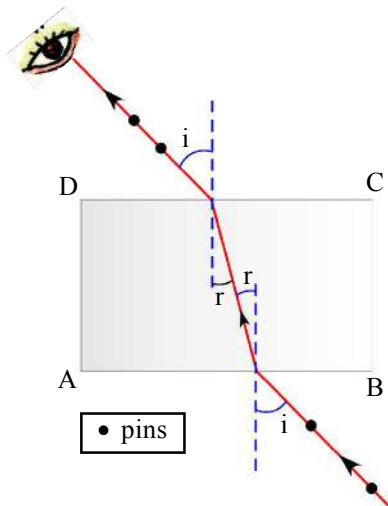

fig-11

Now take another piece of white chart on the plank. Clamp it. Place a glass slab in the middle of the paper. Again draw a border line along the edges of the slab by using a pencil. Remove the slab and name the vertices of the rectangle formed as A,B,C and D. Draw a perpendicular at a point on the longer side AB. Now draw a line, from the point of intersection where side AB of rectangle and perpendicular meet, in such a way that it makes 30° angle with normal. This line represents the incident ray falling on the slab and the angle it makes with normal represents the angle of incidence.

Now place the slab on the paper in such way that it fits in the rectangle drawn. Fix two identical pins on the line making 30° angle with normal such that they stand vertically with equal height. By looking at the two pins from the other side of the slab, fix two pins in such a way that all pins appear to be along a straight line. Remove slab and take out pins. Draw a straight line by joining the dots formed by the pins up to the edge CD of the rectangle. This line represents emergent ray of the light.

Draw a perpendicular ON to the line CD where our last line drawn meets the line CD. Measure the angle between emergent ray and normal. This is called angle of emergence. (Check your drawing with the fig- 11).

- Is the line formed a straight line?
- Are the angles of incidence and emergence equal?
- Are the incident and emergent rays parallel?

You will notice an important result that the incident and emergent rays are parallel.

- Can you find the distance between the parallel rays?

The distance between the parallel rays is called **lateral shift**. Measure this shift. Repeat the experiment for different angles of incidence and tabulate the values of angle of incidence and shift corresponding to each angle of incidence in table (4).

Table 4

Agle of Inciddene	Shift

- Can you find any relation between the angle of incidence and shift?
- Can you find the refractive index of the slab?

Let us find the refractive index of the glass slab.

Activity 8

Let us take a glass slab and measure the thickness of it. Note it in your notebook. Take a white chart and fix it on the table. Take the slab and place it in the middle of the chart. Draw its boundary. Remove the slab from its place. The lines form a rectangle. Name the vertices as A,B,C and D. Draw a perpendicular to the longer line AB of the rectangle at any point on it. Place slab again in the rectangle ABCD. Take a pin. Place at a point P in such a way that its length is parallel to the AB on the perpendicular line at a distance of 15cm from the slab. Now take another pin and by looking at the first pin from the other side of the slab try to place the pin so that it forms a straight line with the first pin.

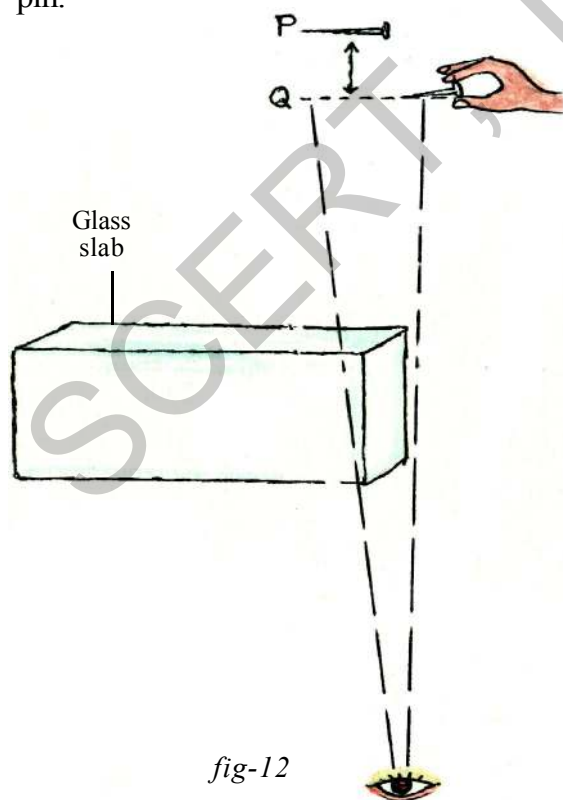

fig-12

Note : While doing this, keep your eye fixed along the edge of the glass slab and first pin is seen through the glass slab, where as second pin is seen through air i.e. outside of the glass slab.

Remove the slab and observe the positions of the pins.

- Are they in the same line?

Draw a perpendicular line from the second pin to the line on which first pin is placed. Call the intersection point Q. Find the distance between P and Q. We may call it **vertical shift**.

- Is this shift independent of distance of first pin from slab?

To find this, do the same activity for another distance of the pin from the slab. You will get the same vertical shift. We could use a formula to find out refractive index of the glass.

$$R.I = \frac{\text{Thickness of the slab}}{(\text{thickness of slab} - \text{vertical shift})}$$



Key words

Refraction, Incident ray, Refracted ray, Angle of incidence, Angle of Refraction, Absolute refractive index, Relative refractive index, Snell's law, Critical angle, Total internal Reflection, Mirage, Shift, Optical fibre.



What we have learnt

- When light travels from one medium to another, its direction changes at the interface. The phenomenon of changing direction at the interface of the two media is known as refraction.
- Absolute refractive index = Speed of light in vacuum/ Speed of light in medium $\Rightarrow n=c/v$.
- Relative refractive index, $n_{21} = \frac{v_1}{v_2} = \frac{n_2}{n_1}$.
- Snell's law is given by, $n_1 \sin i = n_2 \sin r$.
- The angle of incidence, at which the light ray travelling from denser to rarer medium grazes the interface, is called the critical angle for those media. $\sin C = \frac{n_2}{n_1}$, where n_1 is the refractive index of denser medium and n_2 is the refractive index of rarer medium. ($n_1 > n_2$)
- When the angle of incidence is greater than the critical angle, the light ray is reflected into denser medium at interface. This phenomenon is called total internal reflection.



Improve your learning

I. Reflections on concepts

1. The speed of the light in a diamond is 1,24,000 km/s. Find the refractive index of diamond if the speed of light in air is 3,00,000 km/s. (AS₁)
(Ans: 2.42)
2. Refractive index of glass relative to water is 9/8. What is the refractive index of water relative to glass? (AS₁) (Ans: 8/9)
3. The absolute refractive index of water is 4/3. What is the critical angle? (AS₁) (Ans: $\sin C = \frac{3}{4}$)
4. Determine the refractive index of benzene if the critical angle of benzene with respect to air is 42°. (AS₁) (Ans: 1.51)
5. Explain the formation of mirage? (AS₁)
6. Explain the refraction of light through a glass slab with a neat ray diagram. (AS₃)
7. Why do stars appear twinkling? (AS₇)



4. If the angle of incidence is equal to critical angle, then the angle of refraction is []
 a) 0° b) 20° c) 90° d) 180°
5. Mirage is a best example for the phenomenon of []
 a) Reflection b) Refraction c) Total internal reflection d) Shift
6. Refractive indices of Ice, Benzene, Ruby and Kerosene are 1.31, 1.50, 1.71 and 1.44 respectively. In which of the above media, light travels slowly? []
 a) Ice b) Benzene c) Ruby d) Kerosene
7. The relative refractive index of water with respect to air is $\frac{4}{3}$. Then relative refractive index of air with respect to water is []
 a) 4 b) 3 c) $\frac{4}{3}$ d) $\frac{3}{4}$
8. In an experiment to trace the path of ray through a glass slab, Shiva traced as shown in the figure. The teacher asked him to identify the emerging ray. Which of the following would Shiva identify.
 a) AB b) BC
 c) CD d) N_2

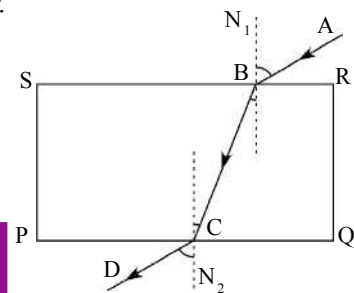

 **Suggested Experiments**

- Verify experimentally that $\frac{\sin i}{\sin r}$ is a constant.
- Organise some activities to understand the phenomenon of total internal reflection
- Conduct an experiment to find the relation between angle of incidence and angle of refraction, when light rays travel from denser to rarer medium.
- Take a bright metal ball and make it black with soot in a candle flame. Immerse it in water. How does it appear and why? (Make hypothesis and do the above experiment).
- Take a glass vessel and pour some glycerine into it and then pour water up to the brim. Take a quartz glass rod. Keep it in the vessel. Observe the glass rod from the sides of the glass vessel.
 - What changes do you notice?
 - What could be the reasons for these changes?

6. Conduct the activity-7 again. How can you find critical angle of water? Explain your steps briefly.
7. Find the critical angle of glass and water with respect to air using activity - 5.



Suggested Projects

1. Collect the refractive indices of the following media. Compare them with those are given in table 1. Findout the pairs of media in which light travels almost with same speed.

Coconut oil, Cooking oil, Hydrogen gas, petrol, diesel, Glycerine, Vinegar, Hydrochloric acid, Transparent plastic.

2. Collect information on working of optical fibres.
3. Prepare a report about various uses of optical fibres in our daily life.

4. Take a thin thermocol sheet. Cut it in circular discs of different radii like 2cm, 3cm, 4cm, 4.5cm, 5cm etc and mark centers with sketch pen. Now take needles of length nearly 6cm. Pin a needle to each disc at its centre vertically. Take water in a large opaque tray and place the disc with 2cm radius in such a way that the needle is inside the water as shown in fig-P4.



fig-P4

Now try to view the free end (head) of the needle from surface of the water.

- Are you able to see the head of the needle?

Now do the same with other discs of different radii. Try to see the head of the needle, each time.

Note: the position of your eye and the position of the disc on water surface should not be changed while repeating the activity with other discs.

- At what maximum radius of disc, were you not able to see the free end of the needle?
- Why were you not able to view the head of the nail for certain radii of the discs?
- Does this activity help you to find the critical angle of the medium (water)?
- Draw a diagram to show the passage of light ray from the head of the nail in different situations.



We have learnt about uniformly accelerated motion in the chapter 'motion'. In this chapter let us study about uniform circular motion which is an example of accelerated motion.

We always observe that an object dropped from certain height falls towards the earth. We know that all planets move around the sun. We also know that the moon moves around the earth. In all these cases there must be some force acting on these objects to make them move around another object, instead of moving in a straight line.

- What is that force?
- Is the motion of the earth around the sun uniform motion?
- Is the motion of the moon around the earth uniform motion?

Newton explained the motion of moon by using the concept of uniform circular motion and then he developed the idea of gravitation between any two masses in the universe.

In this chapter you will learn about gravitation and centre of gravity.

5.1 Uniform circular motion

Activity-1

Observing the motion of an object moving in a circular path

Take an electric motor (which is used in toys) and fix a disc to the shaft of the electric motor. Stick a small wooden block on the disc at the edge as shown in fig.-1 (a). Switch on the motor. Find the time required to complete ten revolutions by the block and repeat the same two to three times. Begin counting revolutions a few seconds after starting the motor.

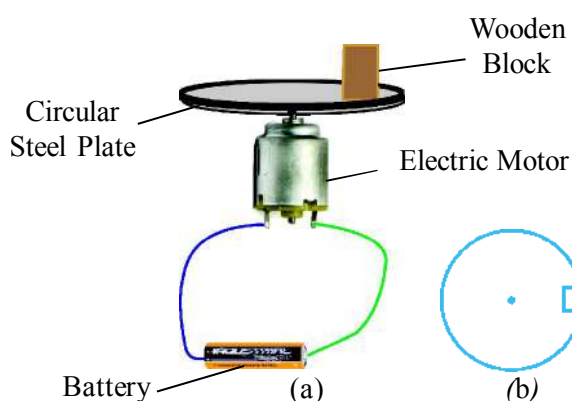

Fig-1: (a) motion of wooden block on a circular plate (b) top view of wooden block

- Is the time of revolution constant?
- Is the speed of the block constant?
- What is the shape of its path?

The wooden block moves in a circular path with a constant speed. So this motion of the wooden block, is uniform circular motion.

"**Uniform circular motion** is motion of the body with a constant speed in a circular path"

- Does the velocity of the body change in uniform circular motion? Why?
- Does the body in uniform circular motion have an acceleration? What is the direction of acceleration?

Activity-2

Take a piece of thread and tie a small stone at one end. Hold the other end of the thread and rotate it round as shown in the Fig-2.



Fig-2

- What is the direction of motion of the stone?

Now release the thread and observe the direction of motion of the stone.

- What is the direction of motion of the stone?

Before the thread is released the stone moves in a circular path, with a certain speed.

When the thread is released, the stone moves in linear motion.

This shows that the original direction of velocity of stone is linear and while in circular motion, the direction of velocity and acceleration always changes thus the stone remains in circular motion. It is clear that the change in direction of velocity makes an object to move in circular motion. This change is caused by an external force.

- Where from the stone gets this force?
- What will be the direction of that force?

The force that causes this change in velocity keeps the stone moving along the circular path is acting towards the centre. This force is called centripetal force.

In the absence of this force (when the thread is released) the stone flies off along a straight line. This line is a tangent to the circular path.

Tangent to a Circle

The straight line which meets the circle at one and only one point is called the tangent to the circle at that point. The point is called tangential point. The tangent is perpendicular to the radius of the circle at that point.

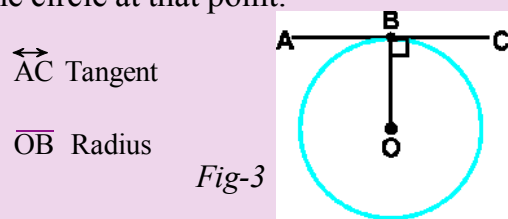

Fig-3

The centripetal acceleration is given

by the formula, $a_c = \frac{v^2}{r}$

Hence the centripetal force-

$$F_c = \frac{mv^2}{r} (\because F_c = ma_c)$$

Where m = mass of the object

v = Velocity of the object

r = Radius of the circular path.

Note : Centripetal force is a net force. It always directed to the centre.



Think and discuss

- Can an object move along a curved path if no force acts on it?
- As a car speeds up when rounding a curve, does its centripetal acceleration increase? Use above equation to justify your answer.
- Calculate the tension in a string that whirls a 2 kg mass toy in a horizontal circle of radius 2.5 m, when it is moving at a speed of 3m/s.

5.2 Universal law of gravitation

Once while Sir Isaac Newton was sitting under a tree, an apple fell to the ground.

- Do you know what questions arose in his mind from this observation?
- Why did the apple fall to the ground?
- Why does the moon not fall to the ground?
- What makes the moon to move in a circular orbit around the earth?

With the above observations Newton assumed that there exists a force between any two objects in the Universe. This force is named as Gravitational force. The generalised law of gravitation as stated by Newton is "Every body in the universe attracts other body with a force which is directly proportional to the product of their masses and inversely proportional to the square of the distance between them". The direction

of the force of attraction is along the line joining the centers of the two bodies.

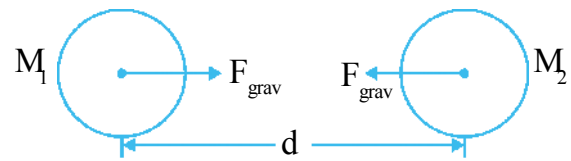

Fig-4

Let two bodies of masses M_1 and M_2 be separated by a distance of 'd', and the force of gravitation between them is F_{grav} .

Force of attraction $\propto (\text{mass})_1 (\text{mass})_2$

$F_{\text{grav}} \propto M_1 M_2$ and

$F_{\text{grav}} \propto \frac{1}{d^2}$

$F_{\text{grav}} \propto \frac{M_1 M_2}{d^2}$

$F_{\text{grav}} = \frac{GM_1 M_2}{d^2}$

G is a proportionality constant, called universal gravitational constant and found experimentally by Henry Cavendish to be $G=6.67 \times 10^{-11} \text{ Nm}^2 \text{ Kg}^{-2}$. The value of G is equal to the magnitude of force between a pair of 1 kg masses that are 1 metre apart.

Note: This formula is applicable to spherical bodies. We use the above formula for all bodies on the earth though they are not spherical because, when compared to the earth, any object on earth is very small and it is assumed to be a point object.

Example 1

What is the time period of satellite near the earth's surface? (neglect height of the orbit of satellite from the surface of the earth) M -Mass of earth = 6×10^{24} kg, R -radius of earth = 6.4×10^6 m.

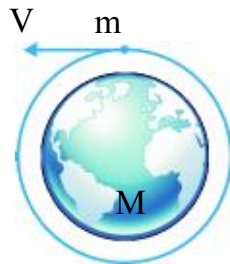

Fig-5

Solution

Let's assume the mass of the earth and radius are ' M ' and ' R '. Mass of the satellite is ' m '. Then, the force on the satellite due to earth is given by $F = \frac{GmM}{R^2}$

Let v be the speed of the satellite

$$v = \frac{2\pi R}{T} \Rightarrow T = \frac{2\pi R}{v}$$

Required centripetal force is provided to satellite by the gravitational force hence $F_c = \frac{mv^2}{R}$.

But $F_c = \frac{GMm}{R^2}$ according to Newton's law of gravitation.

$$\begin{aligned} \text{i.e., } \frac{GMm}{R^2} &= \frac{m(2\pi R)^2}{T^2 R} \\ \Rightarrow T^2 &= \frac{4\pi^2 R^3}{GM} \end{aligned}$$

As mass of the earth (M) and G are constants the value of T depends only on the radius of the earth.

$$\Rightarrow T^2 \propto R^3$$

Substituting the values of M , R and G in above equation we get, $T = 84.75$ minutes.

Thus the satellite revolving around the earth in a circular path near to the earth's surface takes 1 Hour and 24.7 minutes approximately to complete one revolution around earth.

Derivation of the Universal Law of Gravitation

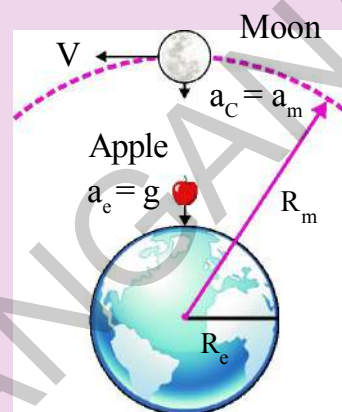

Fig-6: Comparing the motions of the moon and apple

Newton knew that the motion of moon around the earth is approximately uniform circular motion. So certain net force, which we call centripetal force, is required to maintain the uniform circular motion.

So he introduced the idea of force of attraction between the moon and earth. He proposed that earth attracts moon and termed it as gravitational force. This gravitational force acts as a centripetal force and makes the moon revolve around the earth in uniform circular motion.

Newton knew the following data. The distance of the moon from center of the earth is $3,84,400 \text{ km} = 3.844 \times 10^{10} \text{ cm}$. The moon takes 27.3 days or $2.35 \times 10^6 \text{ s}$ for a complete revolution around the earth.

- What is the speed of moon?

You can calculate the speed of the moon using the equation,

$$v = \frac{2\pi R}{T}$$

Thus the acceleration of the moon towards the centre of the earth

$$a_m = \frac{v^2}{R} = \frac{4\pi^2 R}{T^2}$$

Substituting the values of R and T in above equation we can get

$$a_m = 0.27 \text{ cm/s}^2.$$

Galileo found that the acceleration of bodies acquired near the surface of earth is equal to 981 cm/s^2 . Thus acceleration of an apple, approximately is equal to 981 cm/s^2 .

He compared the both the acceleration of an apple, a_e to the acceleration of the moon, a_m .

$$\text{We get, } \frac{a_e}{a_m} = \frac{981}{0.27} \cong 3640 \text{--- (1)}$$

Newton knew that the radius of Earth, R_e and the distance of the moon from the centre of the Earth, R_m are 6371 km and 3,84,400 km respectively. We get

$$\frac{R_m}{R_e} = \frac{384400}{6371} \cong 60.3$$

$$\left(\frac{R_m}{R_e}\right)^2 = (60.3)^2 \cong 3640 \text{----- (2)}$$

From 1, 2 equations it is clear that

$$\frac{a_e}{a_m} = \left(\frac{R_m}{R_e}\right)^2$$

So we get,

$$a \propto \frac{1}{R^2} \text{ ----- (3) and thus,}$$

Force of attraction

$$F \propto \frac{1}{R^2} \text{ ----- (4)}$$

Thus it became clear that the force of gravity decreases with increase in distance of the object from the center of the earth.

According to Newton's third law the force on the apple by the earth is equal to the force on the earth by the apple. We get the force on an object by the earth by using the second law of motion and equation-1.

From Newton's second law of motion $F = ma$, and from equation-1, $a \propto \frac{1}{R^2}$

$\Rightarrow a = \frac{k}{R^2}$ (where k is proportionality constant)

$$\text{Thus we get, } F = \frac{km}{R^2}$$

Therefore the force on the apple by the earth = $\frac{Km}{R^2}$ ---- (5)

Where 'm' is the mass of apple and 'R' is the radius of the earth.

$$\text{Force on the earth by the apple} = \frac{KM}{R^2} \text{----- (6)}$$

Where M is the mass of the earth.

The above forces are equal in magnitude only when the following condition is satisfied.

$$K=GM \text{ and } K' = Gm \text{ ---- (7)}$$

Where G is a constant.

From equations (5) & (7) we have force on apple by the earth, $F = \frac{GMm}{R^2}$

We conclude that gravitational force between the masses is directly proportional to the product of their masses.



Think and discuss

- In fig.-7, we see that the moon 'falls' around earth rather than straight into it. If the magnitude of velocity were zero, how would it move?

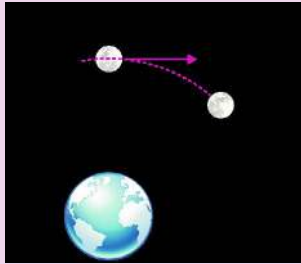

Fig-7

- According to the equation for gravitational force, what happens to the force between two bodies if the mass of one of the bodies doubled?
- If there is an attractive force between all objects, why do we not feel ourselves gravitating toward massive buildings in our vicinity?
- Is the force of gravity stronger on a piece of iron than on a piece of wood if both have the same mass?
- An apple falls because of the gravitational attraction of earth. What is the gravitational attraction of apple on the earth?

5.3 Free fall

Activity-3

Acceleration is independent of masses

Place a small paper on a book. Release the book with the paper from certain height from the ground.

- What is your observation? Now drop the book and paper separately, what happens?

A body is said to be in free fall when only the gravitational force acts on that body.



Fig-8

Let us drop a body of mass m near the earth's surface.

Let M be the mass of the earth and R be the radius of the earth.

Now the force of attraction on the mass is given by,

$$F = \frac{GMm}{R^2} \Rightarrow \frac{F}{m} = \frac{GM}{R^2}$$

From Newton's second law, F/m is equal to acceleration. Here this acceleration is denoted by 'g'

$$\text{Hence, } g = \frac{GM}{R^2}$$

From the above equation you can conclude that 'g' is the independent of the body's mass.

If there were no air friction or resistance, all the bodies would fall with the same acceleration. This acceleration, produced due to gravitational force of the earth near the surface, is called free- fall acceleration.

Mass of the earth (M) = 6×10^{24} kg

Radius of earth (R) = 6.4×10^6 km

Putting these values in the above equation.

We get $g = 9.8 \text{ m/s}^2$ (approximately)

In general, this value of acceleration due to gravity changes due to change in distances of objects from the center of the earth.

Since free - fall acceleration is constant near the ground, the equations of uniform accelerated motion can be used for the case of free-fall body.

$$v = u + at,$$

$$s = ut + \frac{1}{2} at^2,$$

$$v^2 - u^2 = 2as.$$

- While solving problems related to Free fall objects we use 'g' instead of 'a' in above equations.
- When we use these equations, you must follow the sign convention (It is discussed in the chapter "motion")

Activity-4

What is the direction of 'g'?

Throw a stone vertically up. Measure the time required for it to come back to earth's surface with a stop clock.

- What happens to its speed when it moves up and down?
- What is the direction of acceleration?

When a stone moves up, the speed decreases. When a stone moves down, the speed increases. So the free-fall acceleration

is vertically downwards. No matter how you throw objects, "g" is directed vertically down as shown in fig.-9. (Actually the body tends to move towards the centre of the earth).

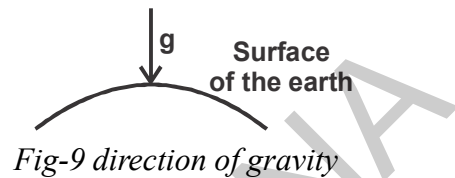

Fig-9 direction of gravity

Observe the following table-1 to know the direction of acceleration.

Table-1

	s	v	a
1	+	+	-g
2	+	0	-g
3	+	-	-g
4	0	-	-g
5	-	-	-g

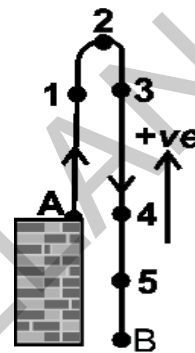

Fig-10



Think and discuss

- Give an example for the motion of an object of zero speed and with non zero acceleration?
- Two stones are thrown into air with speeds 20 m/s, 40m/s respectively? What are accelerations possessed by the objects?

Example 2

A body is projected vertically up. What is the distance covered in its last second of upward motion? ($g = 10 \text{ m/s}^2$)

Solution

The distance covered by the object in its last second of its upward motion is equal to the distance covered in the first second of its downward motion.

Hence $u = 0$ and from $s = ut + \frac{1}{2}at^2$, the distance covered by the last second.

$$s = \frac{1}{2}gt^2 = \frac{1}{2} \times 10 \times 1 = 5 \text{ m}$$

Example 3

Two bodies fall freely from different heights and reach the ground simultaneously. The time of descent for the first body is $t_1 = 2\text{s}$ and for the second $t_2 = 1\text{s}$. At what height was the first body situated when the other began to fall? ($g = 10 \text{ m/s}^2$)

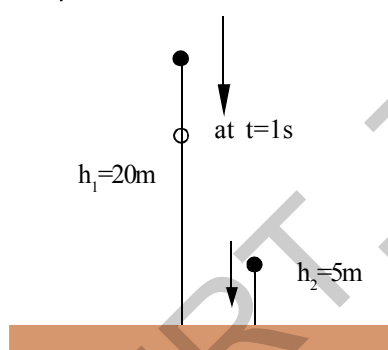

Fig-11

Solution

An object with travel time of 2s is first and the travel time 1s is second object. The distance covered (h_1) by second body in 1s is

$$h_2 = \frac{1}{2}gt^2 = \frac{1}{2} \times 10 \times 1^2 = 5 \text{ m}$$

The distance covered by first body in 2s is h_1 ,

$$h_1 = \frac{1}{2}gt^2 = \frac{1}{2} \times 10 \times 2^2 = 20\text{m}.$$

The height of the first body when the other begin to fall $h = 20 - 5 = 15\text{m}$.

Example 4

A stone is thrown vertically up from the tower of height 25m with a speed of 20 m/s. What time does it take to reach the ground? ($g = 10 \text{ m/s}^2$)

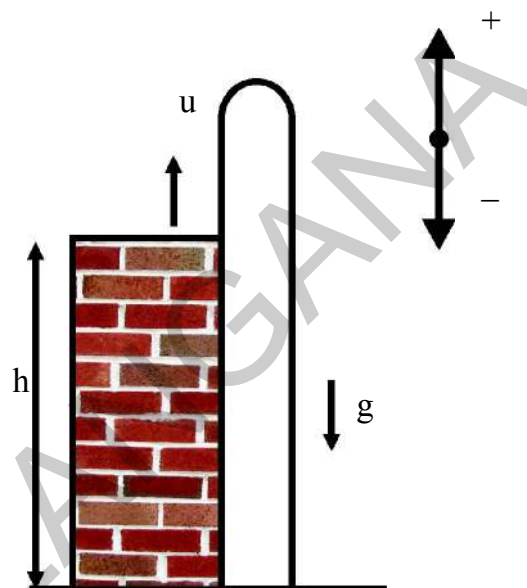

Fig-12

Solution

Sign convention must be used to solve this problem. It is shown in fig.-12.

Take the point from which the stone is thrown as the fixed point. From this point upward positive and downwards negative.

$$\text{Then, } u = 20 \text{ m/s}$$

$$a = g = -10 \text{ m/s}^2$$

$$s = h = -25 \text{ m}$$

From equation of motion $s = ut + \frac{1}{2}at^2$

$$-25 = 20t - \frac{1}{2} \times 10 \times t^2$$

$$-25 = 20t - 5t^2$$

$$-5 = 4t - t^2$$

$$\Rightarrow t^2 - 4t - 5 = 0$$

Solving this equation,

$$\text{We get, } (t - 5)(t + 1) = 0$$

$$t = 5 \text{ or } -1$$

$$t = 5\text{s}$$

The time it takes for the stone to reach the ground is 5s.

Example 5

Find the time taken, by the body projected vertically up with a speed of 'u', to return back to the ground.

Solution

Let us take the equation $s = ut + \frac{1}{2} a t^2$

For entire motion $s = 0$

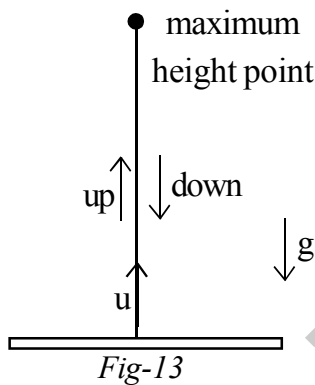

$$a = -g$$

$$u = u$$

$$0 = ut - \frac{1}{2}gt^2$$

$$\frac{1}{2}gt^2 = ut$$

$$t = 2u/g$$

5.4 Weight

Weight of a body is the force of attraction on the body due to earth. So, from Newton's second law of motion.

$$F_{\text{net}} = ma$$

We get,

$$W = mg$$

It is measured in newtons

1 kg body weighs 9.8 N

2 kg body weighs 19.6 N

10kg body weighs 98 N

Activity-5

Can we measure the weight of free-fall body?

Let us find,

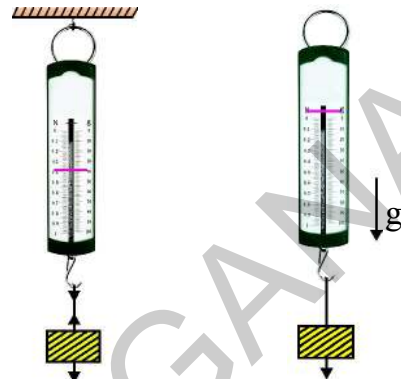

Take a spring balance and suspend it to the ceiling and put some weight to it. Note the reading of the spring balance. Now drop the spring balance with load from certain height to fall freely. Carefully observe the change in the position of indicator on the spring balance scale while it is in free-fall.

- What changes do you notice in the readings of spring balance in above two instances?
- Are the readings same? If not why?

Some of you might have the experience of diving into a swimming pool from certain height. (Don't try if you are not a swimmer).

- How do you feel during free-fall of your body from a height?

Activity-6

Observing the changes during the free-fall of a body

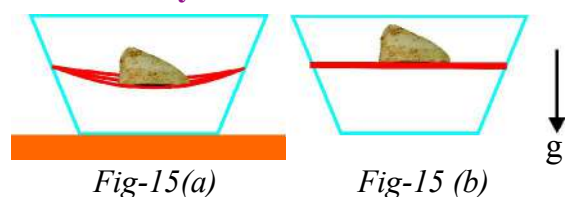

Take a transparent tray and make holes on opposite sides. Take two or three rubber bands and tie them tightly, close to each other between the holes. Now place a stone on the bands as shown in the figures 15(a) and 15(b).

- Do the bands bend?

Now drop the tray with stone.

- Now what happens?

We get the following results in free fall.

In spring - mass activity, the reading becomes zero. In jumping, the man feels weightlessness. In the activity-6, the bands are straight. No stretch occurs in the rubber bands. We treated the weight of an object as the force due to gravity upon it.

When in equilibrium on a firm surface, weight is balanced by a support force or when in suspension, by a supporting tension. In either case with no acceleration, weight equals to mg . A support force can occur without regard to gravity. The definition of the weight of something is the net force it exerts against a support.



Think and discuss

- When is your weight equal to mg ?
- Give example of when your weight is zero?

5.5 Centre of gravity

Activity-7

Balancing of objects



Fig-16: Balancing of fork

Fasten a fork, spoon, and wooden match stick together as shown. The combination will balance nicely - on the edge of the glass as shown in Fig-16. Why?

Activity-8

Can you get up without bending?



Fig-17

Sit in a chair comfortably as shown in fig-17. Try to get up from the chair without bending your body or legs.

- Are we able to do so? If not why?

Activity-9

5.6 Balancing a ladder

Try to balance a ladder on your shoulder?

When does it happen?

We need to introduce the idea of "Centre of gravity" to understand this observation.

The center of gravity is simply the average position of weight distribution. The point where total weight appears to act is called **centre of gravity**.

Activity-10

Locating centre of gravity

Take a meter scale. Suspend it from various points. What do you notice? Suspend it from its mid point. What happens?

The center of gravity of a uniform object, such as meter scale, is at its midpoint. The stick behaves as if its entire weight was concentrated at that point. The support given to that single point gives support to the entire scale. Balancing an object provides a simple method of locating its centre of gravity.

See the Fig-18. The many small arrows represent the pull of gravity all along the meter scale. All of these can be combined into a resultant force acting through the centre of gravity.

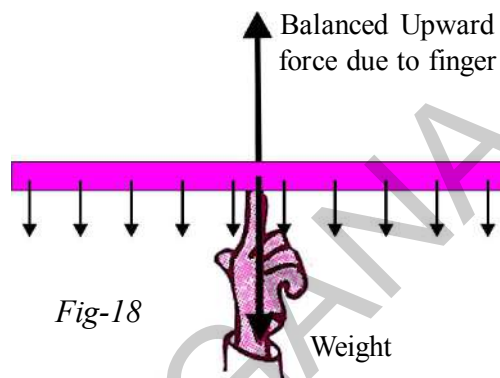

Fig-18

The entire weight of the scale may be thought of as acting at this single point. Hence we can balance the scale by applying a single upward force at this point.

- How to find the center of gravity of an object?

The center of gravity of any freely suspended object lies directly beneath the point

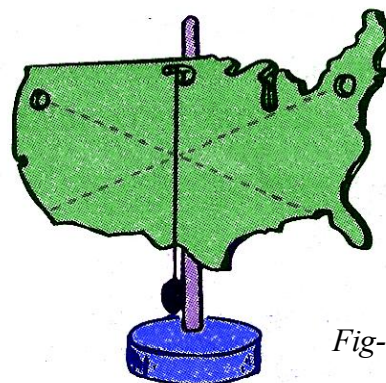

Fig-19

If a vertical line is drawn through the point of suspension, the center of gravity lies somewhere along that line. To determine exactly where it lies along the line, we have only to suspend the object from the some other point and draw a second vertical line through that point of suspension. The center of gravity lies where the two lines intersect.

Activity-11

Identifying the center of gravity of a ring

Find the centre of gravity of ring using the method explained in the above example.

- Where does the center of gravity of a ring lie?
- Does the center of gravity of a body exist outside the body?
- Does center of gravity of an object exist at a point where there is no mass of the object?

5.7 Stability

The location of the centre of gravity is important for stability. If we draw a line straight down from the centre of gravity of an object of any shape and it falls inside the base of the object, then the object will be stable.

If the line through the center of gravity falls outside the base then the object will be unstable.

Activity-12

Shift of the center of gravity and its effects

When you stand erect, where is your centre of gravity?



Fig-20 (a)

Fig-20 (b)

Try to touch your toes as shown in fig.- 20 (a). Try this again when standing against a wall as shown in fig.- 20 (b).

- Are you able to touch your toes in second case as shown in fig-20(b)? If not why?
- What difference do you notice in the center of gravity of your body in the above two positions?



Think and discuss

- Where does the centre of gravity of a sphere and triangular lamina lie?
- Can an object have more than one centres of gravity?
- Why doesn't the leaning tower of Pisa topple over?
- Why must you bend forward when carrying a heavy load on your back?



Key words

Uniform circular motion, centripetal acceleration, centripetal force, centre of gravity, law of gravitation, gravity weight, weightlessness, stability, free fall.



What we have learnt

- Motion of body with constant speed in a circular path is called uniform circular motion.
- The acceleration which causes changes only in direction of the velocity of a body in circular motion is called centripetal acceleration and it is always directed towards the center of the circle.
- The net force required to keep a body in uniform circular motion is called "Centripetal force". $F_c = \frac{Mv^2}{R}$.
- Every object in the universe attracts other bodies. The force of attraction between the bodies is directly proportional to the product of masses and inversely proportional to the square of the distance between them.
- All the bodies have the same acceleration (9.8m/s^2) near the surface of the earth. But this acceleration slightly decreases as we move away from the surface of the earth.
- A body is said to be in free fall when only gravity acts on it. (its acceleration is 'g')
- Weight of an object is the force of gravity acting on it. $W = mg$
- During free fall condition, the body is in state of 'weightlessness'.
- The center of gravity is the point where total weight of the body acts.
- The body is in equilibrium when the weight vector goes through the base of the body.



Improve your learning



H2S7F3

I. Reflections on concepts

1. How do you explain that an object is in uniform circular motion (AS_1)
2. Calculate the acceleration of the moon towards earth's center. (AS_1)
3. Explain universal law of gravitation. (AS_1)
4. Explain some situations where the center of gravity of man lies outside the body. (AS_1)
5. Explain why a long pole is more beneficial to the tight rope walker if the pole has slight bending. (AS_7)

II. Application of concepts

1. A car moves with constant speed of 10 m/s in a circular path of radius 10m. The mass of the car is 1000 kg. How much is the required centripetal force for the car?
(Ans: 10^4N) (AS_1)
2. A ball is projected vertically up with a speed of 50 m/s. Find the maximum height, the time to reach the maximum height, and the speed at the maximum height
($g=10\text{ m/s}^2$) (AS_1) (Ans: 125m; 5s; zero)
3. Two spherical balls of mass 10 kg each are placed with their centers 10 cm apart. Find the gravitational force of attraction between them. (AS_1) (Ans: 10^4G. Newton)
4. A ball is dropped from a height. If it takes 0.2s to cross the last 6m before hitting the ground, find the height from which it is dropped. Take $g = 10\text{m/s}^2$ (AS_1)
(Ans: 48.05m)
5. What path will the moon take when the gravitational interaction between the moon and earth disappears? (AS_2)
6. Why is it easier to carry the same amount of water in two buckets, one in each hand rather than in a single bucket? (AS_7)

III. Higer Order Thinking questions

1. A man is standing against a wall such that his right shoulder and right leg are in contact with the surface of the wall along his height. Can he raise his left leg at this position without moving his body away from the wall? Why? Explain. (AS_7)
2. An apple falls from a tree. An insect in the apple finds that the earth is falling towards it with an acceleration 'g'. Who exerts the force needed to accelerate the earth with this acceleration? (AS_7)



Multiple choice questions

1. The acceleration which can change only the direction of velocity of a body is called []
a) Acceleration due to gravity b) Uniform acceleration
c) Centripetal acceleration d) Deceleration
2. The distance between the Earth and the Moon is []
a) 3,84,400 Km b) 3,84,400 cm
c) 84,000 Km d) 86,000 Km

3. The value of Universal Gravitational Constant is []
a) $6.67 \times 10^{-11} \text{N.m}^2\text{Kg}^{-2}$ b) 9.8 m/ Sec^2
c) $6.67 \times 10^{-12} \text{N.m}^2\text{Kg}^{-2}$ d) 981 m/ Sec^2
4. The weight of an object whose mass is 1 Kg is []
a) 1 Kg/m^2 b) 9.8 m/Sec^2 c) 9.8 N d) 9.8 N/m^2



Suggested Experiments

1. Conduct an experiment to find the Centre of Gravity of an object and write a report.
2. Conduct an experiment to find $\frac{2s}{t^2}$ value for a freely falling body and also find the value of 'g'.



Suggested Projects

1. Collect the information about the base area and stability of some objects with different shapes and write a report.
2. Collect information about the path of revolution of moon around the earth and write a report.



P8B8G6

You might have gone to the market many times with your parents to purchase rice, salt, milk, ghee and other provisions. You must have tried to ensure that you got the purest possible milk and pure ghee etc. In our day to day language, 'pure' means something with no adulteration. But in chemistry pure means something different.

Let us find out what is pure in chemistry.

Activity-1

6.1 Is full cream milk pure?

Take some milk in a vessel. Spin it with a milk churner for some time. (See fig-1)



Fig-1: Churning of milk

After some time, you observe separation of a paste like solid out of the milk. This paste like solid called cream. So full cream milk contains more than one component like fat and water. It is therefore a mixture. We have already studied about mixtures in previous classes. Let us learn more about them.

Churning makes the lighter components to come to the surface when a mixture of liquids are spun rapidly. Commercially for separating the cream from milk, a machine called centrifuge is used. It follows the same principle. Centrifugation



Fig-1(A): Centrifuge

is also used in a diagnostic laboratory, to test blood and urine samples. The sample is taken in a centrifugation tube and the centrifugation tube is

placed in a centrifugation machine. On rotation of the tubes with machine, the heavier particles settle to the bottom and the lighter particles come to the top of the test tube.



Think and discuss

How does a laundry dryer squeeze out water from wet clothes?

6.1.1 What is a mixture?

Many things that we call pure are actually mixtures of different substances.

Juice is a mixture of water, sugar and fruit pulp. Even water we drink contains some salts and minerals. All the matter around us can be classified into two groups – pure substances and mixtures.

When a scientist says that something is pure, he means that the composition of the substance doesn't change, no matter which part of the substance you take for examination.

For example, whichever part of a pure gold biscuit is taken as a sample, the composition is found to be same throughout. (See fig.-2)

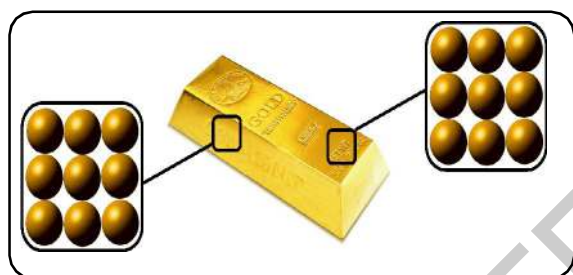

Fig-2: Pure gold biscuit

But, the composition in mixtures is not always same. The composition in some mixtures change, depending on the part you have taken as a sample.

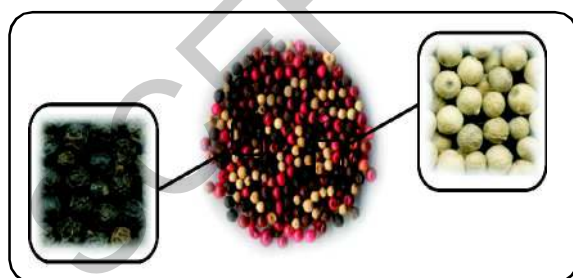

Fig-3: Mixture

A mixture is generally made of two or more components that are not chemically combined. The substances in a mixture retain their own properties, and they can be physically separated.

- What would you notice from the fig.-4a and 4b?

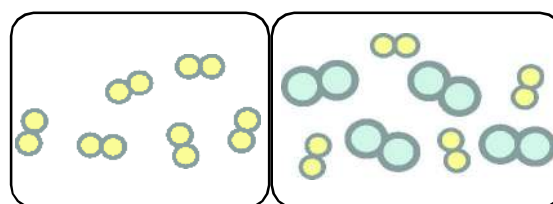

Fig-4: (a) Pure substance 4(b) Mixture

6.2 Types of mixtures

You have learnt about a mixture. Do you know the types of mixtures? What are they? Let's find out.

Mixtures can be in solid, liquid gaseous states or the combination of these three states.

Activity-2

Finding out homogeneous and heterogeneous mixtures

Take two test tubes, Now add one tea spoon of salt to both the test tubes. Fill one test tube with water and other with kerosene and stir them.

- What do you notice ?

In the first test tube you can observe that the salt dissolves completely. Such types of mixtures are called **homogeneous mixtures**. In other test tube salt is not dissolved. What do you conclude from this? Think!

In a homogeneous mixture the components of mixture are uniformly distributed throughout the bulk. The components of a homogeneous mixture are too intimately mixed up that it will be difficult to distinguish them from one another by visual observation. For example air is a homogeneous mixture of many gases.

We all prepare a drink 'lemonade' and enjoy its taste. It is a mixture of water, sugar, lemon juice and salt. Is it homogeneous or not? If you taste a spoonful of lemonade, it tastes the same throughout. The particles of sugar, lemon juice and salt are evenly distributed in this solution and we cannot see the components separately. We call such mixtures as homogeneous mixtures.

- Can you give few more examples of this kind?

You have observed in the above activity the salt added to kerosene has not dissolved in it. Mixtures of this type are called **heterogeneous mixtures**.

Heterogeneous mixture is a mixture made up of different substances. Which are not uniformly distributed in it. For example the mixtures "oil and water", "naphthalene and water" are heterogeneous mixtures.

Thus we can conclude that mixtures are two types homogeneous and heterogeneous. Do you know that these can again be classified into different kinds? Let us find out.

6.3 Solutions

All of us enjoy drinking soda water and lemonade. We know that they are examples of homogeneous mixtures. The homogeneous mixture of two or more substances is called a **solution**. Solutions can be in the form of solids, liquids, or gases. A solution has minimum two components, a solvent and a solute. The component of the solution that dissolves the other component in it (usually the component present in larger quantity) is called **solvent**. The component of solution usually the component present in lesser quantity that is dissolved in the solvent is called **solute**.

A solution of sugar is prepared by dissolving the sugar in water. In this solution, sugar (solid) is the solute and water (liquid) is the solvent. In the solution of iodine in alcohol (tincture of iodine) iodine (solid) is the solute and alcohol (liquid) is the solvent. All the aerated drinks are liquid solutions containing carbon dioxide (gas) as solute and water as solvent.

Can you give some more examples for solutions and tell the solute and solvent present in those solutions?



Think and discuss

- "All the solutions are mixtures, but not all mixtures are solutions". Discuss about the validity of the statement and give reasons to support your argument.
- Usually we think of a solution as a liquid that contains either a solid, liquid or a gas dissolved in it. But, we can have solid solutions. Can you give some examples?

Properties of a solution

In a solution the particles are so small in size that we cannot see them with our naked eyes. They do not scatter a beam of light passing through the solution and hence the path of light is not visible in a solution.

- Can you prove this with an experiment?
- If the solution is diluted, can the path of light be visible?

One more interesting property of solution is that, the solute particles do not settle down when left undisturbed. Can you give a reason? If the solute particles are settling down in a solution can we call it as a homogeneous mixture?

- What would happen if you add a little more solute to a solvent?
- How do you determine the percentage of the solute present in a solution?

6.3.1 Concentration of a solution

Can we dissolve as much solute as we want in a given solvent? How do you decide the amount of solute that dissolves in a solvent?

Solubility is the number of grams of a solute that desolves in 100g. of solvent to form a saturated solution at a given temperature.

For example, take one gram of sugar and add 50ml of water to it. Also take 30gm of sugar and add the same amount of water to it in another beaker. Which one of the above solutions is called as dilute and which one is called concentrated?

Activity-3

Preparation of saturated and unsaturated solutions

Take 50 ml of water in an empty cup. Add one spoon of sugar to the water in the cup and stir until it dissolves. Keep on adding sugar to the cup and stir till no more sugar can be dissolved in it. How many spoons of sugar is added ?



Fig.5: Adding Sugar to water

When no more solute can be dissolved in the solution at a certain temperature, it is said to be a **saturated solution**. In a saturated solution, equilibrium with the undissolved solute at a certain temperature.

If the amount of solute present in a solution is less than that in the saturated solution, is called an **unsaturated solution**.

Can you tell what is saturation level? Is it the same for all solutions?

Now take the solution prepared by you into a beaker and heat it slowly by 5° to 6°C above the Room Temperature (do not boil). The undissolved solute dissolves. Add some more sugar to this solution. You notice that more sugar dissolves in it easily when it is heated.



Fig.6: Adding more sugar to water

Find out whether this is true for the salt solution also.

Activity-4

Factors affecting the rate of dissolving

Take three glass beakers and fill each of them with 100 ml of water. Add two spoons of salt to each beaker. Place the first beaker undisturbed, stir the water in the second beaker and warm the third beaker.

What do you observe from the above three situations? Which method allows the solute to dissolve in the solvent easily? If you increase the temperature of the third beaker, what will happen? Repeat the activity by using salt crystals instead of salt powder. What change do you observe?

What are the factors that affect the rate of the solubility of a solute?

From this activity we can conclude that the temperature, size of the solute particles, and stirring are some of the factors that affect the rate of solubility of solute in a solvent.

You know that solubility is the measurement of amount of solute that dissolves in a solvent at a certain temperature. If the amount of solute present is little, the solution is said to be **dilute**, and if the amount of solute present is more, the solution is said to be **concentrated**.

The concentration of a solution can be defined as the amount in grams (mass) of solute present in 100 grams of (mass) solution or the amount (mass) in grams of solute present in 100 ml of the solution.

There are many ways of expressing the concentration of a solution, we learn only about three of those.

$$(i) \text{ Mass percentage of a solute} = \frac{\text{Mass of solute}}{\text{Mass of solution}} \times 100$$

$$(ii) \text{ Volume percentage of a solute} = \frac{\text{Volume of solute}}{\text{Volume of solution}} \times 100$$

$$(iii) \text{ Mass by volume percentage of a solute} = \frac{\text{Mass of solute}}{\text{Volume of solution}} \times 100$$

Example - 1

A solution contains 50g of common salt in 200g of water. Calculate the concentration in terms of mass by mass percentage of the solute?

Solution

Mass of solute (salt) = 50g

Mass of solvent (water) = 200g

$$\begin{aligned} \text{Mass of solution} &= \text{Mass of solute} + \text{Mass of solvent} \\ &= 50\text{g} + 200\text{g} = 250\text{g} \end{aligned}$$

$$\begin{aligned} \text{Mass percentage of a solute} &= \frac{\text{Mass of solute}}{\text{Mass of solution}} \times 100 \\ &= \frac{50}{250} \times 100 = 20\% \end{aligned}$$

Example - 2

80ml of solution contains 20 g of solute. Calculate the concentration in terms of mass by volume percentage of the solution.

6.4 Suspensions and Colloidal Solutions

Activity-5

Finding of heterogeneous mixtures- suspensions and colloids

Take some chalk powder in a test tube. Take a few drops of milk in another test tube. Add water to these samples and stir with a glass rod. Observe whether the particles in the mixtures are visible. Can you call these mixtures as solutions? (Hint: Are the above solutions heterogeneous or homogeneous?)

Now do the following steps and write your observations in the table-1.

- Direct a beam of light from a torch or a laser beam on the test tubes. Is the path of the light beam visible in the liquid?
- Leave the mixture undisturbed for some time. What changes do you observe? Does the solute settle down after some time?
- Filter the mixtures. Did you find any residue on the filter papers?

Record your observations in the table - 1

Table-1

Mixture	Is the path of the light beam visible? (Yes/No)	Did solute settle down? (Yes/No)	Residue is seen on the filter paper (Yes/No)
Chalk, Water			
Milk, Water			

We find that the particles of chalk did not dissolve but remained suspended throughout the volume of the water. So this is a heterogeneous mixture because the solute particles didn't dissolve and the particles are visible to naked eye. Such heterogeneous mixtures are called **suspensions**. "Suspensions are the heterogeneous mixtures of a solid and a liquid, in which the solids do not dissolve, like mixture of soil and water".

In activity-5, particles of milk in the second test tube are uniformly spread throughout the mixture. Due to smaller size of milk particles it appears to be homogeneous but it is a heterogeneous mixture. These particles easily scatter a beam of visible light. Such mixtures are called **colloids or colloidal solutions**. These mixtures possess the characteristics in between a solution and a suspension. (They are also called as colloidal dispersions. Colloidal dispersions may appear homogeneous but are actually heterogeneous.)

A large number of substances such as milk, butter, cheese, cream, gel, boot polish, and clouds in the sky etc. are some more examples of colloids.



Think and discuss

- Have you ever observed carefully the syrup that you take for cough? Why do you shake it before consuming?
- Is it a suspension or colloidal solution?

Colloidal solutions are heterogeneous in nature and always consist of at least two phases; **the disperse phase and the dispersion medium**. Disperse phase is the substance that present in small proportion and consists of particles of colloidal size (**1nm to 100nm**).

Dispersion medium is the medium in which the colloidal particles are dispersed. These two phases can be in the form of solid, liquid or a gas. Thus, different types of colloidal solutions are possible depending upon the physical state of the two phases.

Here are some common examples of colloids from our daily life. (See table-2) Don't try to memorize this table-2, it is given only for your information.

We studied that the particles in a colloidal solution can easily scatter a beam of visible light. This scattering of a beam of light is called the **Tyndall effect**, named after the scientist who discovered it.

You may observe this effect in your day to day life when a fine beam of light enters a room through a small hole or slit. You can try to see Tyndall effect at your home.

Select a room where the sunlight falls directly through a window. Close the windows in such a way that a slit is left open between the windows. (Don't close completely). What do you see?

Table-2: Type of Colloids and their Examples based on dispersion medium and dispersed phase

Dispersion Medium	Dispersed Phase	Colloid type	Examples
Gas	Liquid	Aerosol	Fog, clouds, mist
Gas	solid	Aerosol	Smoke, automobile exhaust
Liquid	Gas	Foam	Shaving cream
Liquid	Liquid	Emulsion	Milk, face cream
Liquid	solid	Sol	Mud, milk of magnesia
Solid	Gas	Foam	Foam, rubber, sponge, pumice stone
Solid	liquid	Gel	Jelly, cheese, butter
Solid	solid	Solid sol	Coloured gem stone, milky glass

You can also observe this phenomenon while walking on a road having a lot of trees on both sides. When the sunlight passes through branches and leaves you see the path of dust particles.

Try to observe the Tyndall effect in the kitchen when the smoke from the stove is exposed to sun light.

- Did you ever observe this phenomenon in the cinema halls?
- Have you ever got an opportunity of going through deep forests? If you go through deep forest you can experience this effect.



Fig-7: Tyndall effect in the forest

When sunlight passes through the canopy of a dense forest; mist contains tiny droplets of water, which act as particles of colloid dispersed in air.



Fig- 8: Ice cream

Is ice-cream a colloid ?

Ice cream is made by churning a mixture of milk, egg sugar and flavours. This mixture is slowly chilled to form ice cream. The churning process disperses air bubbles into the mixture by foaming and breakup the large ice crystals into tiny particles. The result is a complex substance

which contains solids (milk fats and milk proteins), liquids (water) and gases (air bubbles). Now can you guess whether ice cream a colloid or not?

Can you explain now in a comparative way about suspensions and colloids? Let us see.



Think and discuss

- Is there any difference between a true solution and colloidal solution? If you find the differences, what are those differences?

Table-3: Properties of suspension and colloids

Suspensions	Colloids
Suspensions are heterogeneous mixtures.	Colloids are heterogeneous mixtures.
The particles of suspensions can be seen with be naked eyes.	The size of particles of colloid are too small to seen by naked eyes.
The particles of suspensions scatter a beam of scatter light passing through it and make its path visible.	The particles of colloids are big enough to a beam of light passing through it which makes its path visible.
The solute particles settle down when a suspension is kept undisturbed. When the quite particles settle down it does not scatter light any more.	The particles don't settle down when the colloid left undisturbed. i.e., colloid is quite stable.
Suspension is unstable. The components can be separated from the mixture by the process of filtration or decantation.	The components cannot be separated from the mixture by the process of filtration but Centrifugation technique is used in separation.

6.5 Separating the components of a mixture

Till now we have discussed the types of mixtures. Do you know techniques to separate these mixtures into their respective constituents?

Usually heterogeneous mixtures can be separated into their respective constituents by simple physical methods like

handpicking, sieving, filtration etc., as we use in our day to day life.

Sometimes special techniques have to be used for the separation of the components of mixture. We have learnt in class VI, how to separate mixtures in various ways like, flotation, filtration, crystallization, chromatography etc. Let us see more.

6.6 Sublimation

Activity-6

Separation of components of mixture by sublimation

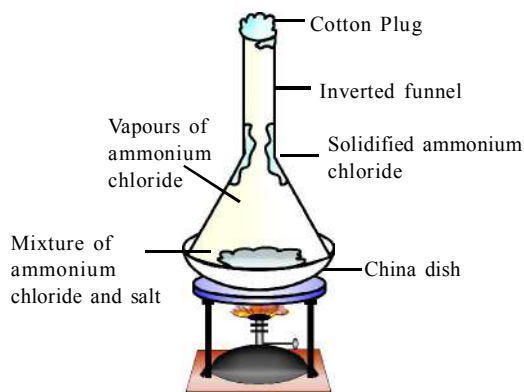

Fig-9: Separating ammonium chloride and salt

Take one table spoon of common salt, one tablespoon of ammonium chloride and mix them.

- Is the mixture heterogeneous? Give reasons.
- How do we separate the salt and ammonium chloride?

Take the mixture in a china dish. Take a glass funnel which is big enough to cover the dish. Plug the mouth of the funnel with cotton and invert it over the dish as shown in fig.-9. Keep the dish on the stand of stove and heat for some time and observe the walls of the funnel. Initially you find vapours of ammonium chloride and then solidified ammonium chloride on the walls of the funnel.

Try it for mixtures that have camphor or naphthalene.



Think and discuss

- Why do we use different separation techniques for mixtures like grain and husk as well as ammonium chloride and salt though both of them are heterogeneous mixtures?
- What is the basis for choosing a separation technique to separate mixtures?

6.7 Evaporation

Activity-7

Process of evaporation of water

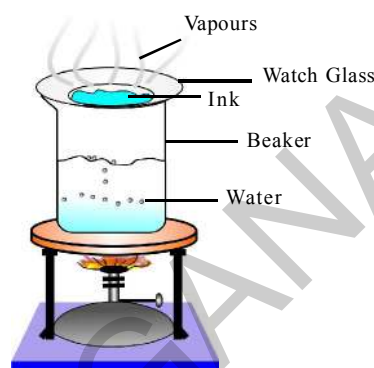

Fig-10: Evaporation of water

Take a beaker and fill it to half its volume with water. Keep a watch glass on the mouth of the beaker as shown in fig.-- 10. Put few drops of ink on the watch glass. Heat the beaker and observe the watch glass. Continue heating till you do not observe any further change on the watch glass.

What is evaporated from the watch glass? Is there any residue on the watch glass?

We know that ink is a mixture of a dye in water. We can separate the components in the ink using evaporation.



Think and discuss

- Is it possible to find out adulteration of kerosene in petrol with this technique?

In activity-7 we saw that ink is a mixture of solute and solvent. Is the dye in ink a single colour? How many dyes are there in ink? How can we find out those? Is there any technique to separate the different components in the ink? That is where chromatography would help.

Chromatography is a laboratory technique for the separation of mixtures into its individual components. We can use chromatography to separate components in ink. The process can also be used to separate the coloured pigments in plants and flowers. It is used to determine the composition of mixtures.

6.8 Paper Chromatography



Lab Activity

Aim: Separating the components of ink using paper chromatography.

Material required: Beaker, rectangular shaped filter paper, black marker (non-permanent), water, pencil and cello tape.

Procedure : Draw a thick line just above the bottom of the filter paper using the marker. Pour some water in the beaker and hang the paper strip with the help of a pencil and cello tape in such a way that it should just touch the surface of water as shown in fig.- 11. Make sure that the ink line or mark does not touch the water.

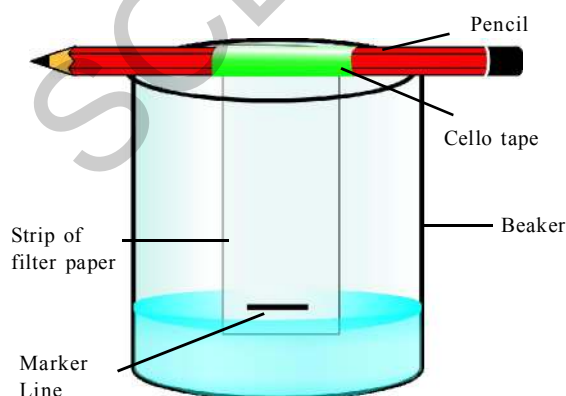

Fig-11: Separating the components of ink

Allow the water to move up the paper for 5 minutes and then remove the strip from water. Let it dry.

What colours did you observe in the black ink sample?

Take two more paper strips and markers as samples and do the experiment. Do the colours occur in the same order and in the same location on all the samples?

Instead of non permanent marker use a permanent marker. What will you observe?

Now touch the marker line to water. What will you notice?

Instead of thick line, draw a thin line on the paper strip with non- permanent marker? Will your results change in each case?

- Is chromatography used only to separate components of coloured compounds?

6.9 Separation of immiscible and miscible liquids

A liquid is said to be miscible if it dissolve completely in another liquid. For example alcohol is miscible in water. Can you give some more examples for miscible liquids?

An immiscible liquid is one which doesn't dissolve but forms a layer over another liquid and can be separated easily like oil is immiscible in water.

Can you name any such liquids from your daily observation?

Do you know how to separate immiscible liquids?

Activity-8

6.9.1 Separation of immiscible liquids

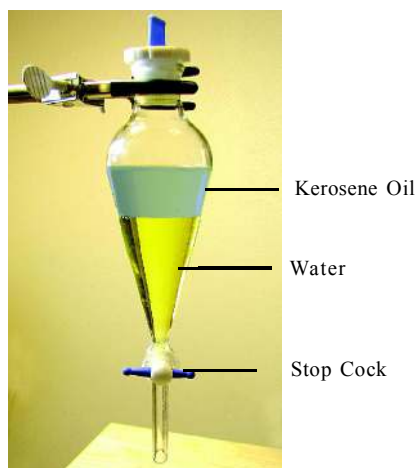

Fig-12: Separating funnel

You must have seen a mixture of oil and water. How many layers do you observe? How do you separate the two components?

Take a separating funnel and pour the mixture of kerosene and water in it. Let it stand undisturbed for some time. So that separate layers of oil and water are formed. Open the stopcock of the separating funnel and pour out the lower layer (water) carefully. Close the stopcock of the separating funnel as the oil reaches the stop-clock. This method is used to separate immiscible liquid according to their density.

6.9.2 Separation of a mixture of two miscible liquids

Sometimes a homogeneous solution is formed by the mixing of liquids. Some liquids have the property of mixing in all proportions, forming a homogeneous solution. Water and ethanol, for example,

are miscible because they mix in all proportions. How can we separate such mixtures?

6.10 Distillation

Activity-9

Separation of two miscible liquids by distillation

Acetone and water are also miscible. Take a mixture of acetone and water in a distillation flask. Fit it with a thermometer and clamp it to stand. Attach the condenser to the flask and on the other side of the condenser keep a beaker to collect distillate. Heat the mixture slowly keeping a close watch on the thermometer. The acetone vaporizes and condenses in the condenser. Acetone can be collected from the condenser outlet. Water remains in the distillation flask.

The separation technique used above is called **distillation**. Distillation is used in the separation of components of a mixture containing two miscible liquids. But there should be a large difference in the boiling points of the two liquids.

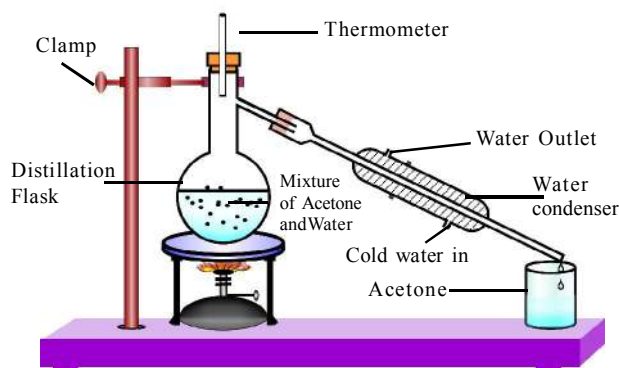

Fig-13: Separating the mixture of Acetone and water by distillation

6.11 What if the boiling points of the two liquids are close to each other?

To separate two or more miscible liquids when the difference in their boiling points is less than 25°C , fractional distillation process is used. If the difference in boiling points is greater than 25°C , a simple distillation is used.

Do you know what process of fractional distillation is?

The apparatus is similar to that for simple distillation except that a fractionating column is fitted in between the distillation flask and the condenser. A simple fractionating column is a tube packed with glass beads. The beads provide maximum possible surface area for the vapours to cool and condense repeatedly as shown in Fig. 14

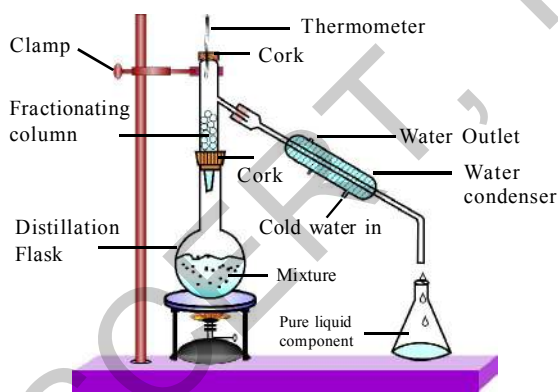
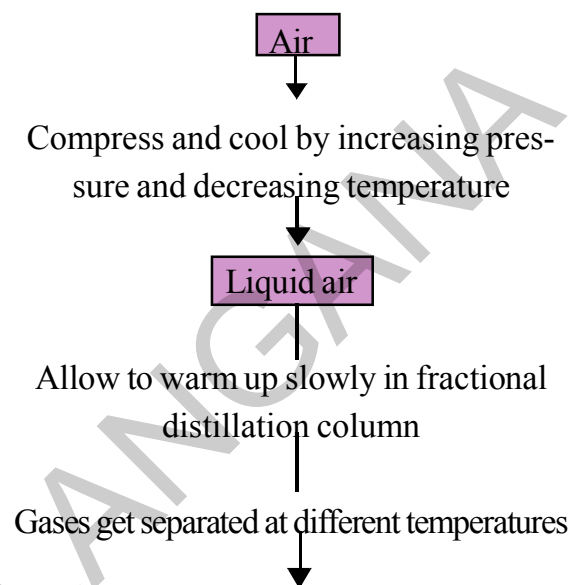

Fig-14: Fractional distillation

- Can you give any examples where we use this technique?
- How can we obtain different gases from air ?

We have learnt that air is a homogeneous mixture. Can it be separated into its components?

Let's see the flow chart which gives the steps of the process.



Points	Oxygen	Argon	Nitrogen
Boiling points ($^{\circ}\text{C}$)	-183	-186	-196
% air by volume	20.9	0.9	78.1

Flow chart shows the process of obtaining gases from air

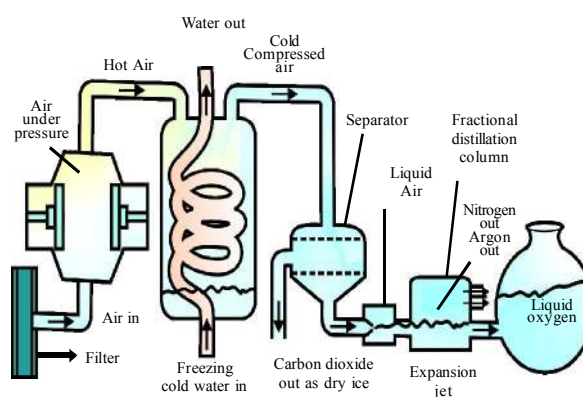

Fig-15: Separation of components of air

If we want oxygen gas from air (fig.--15), we have to separate out all the other gases present in the air. The air is compressed by increasing the pressure and is then cooled by decreasing the temperature to get liquid air. This liquid air is allowed to warm up slowly in a fractional distillation column where gases separated at different temperatures depending upon their boiling points.



Think and discuss

- Arrange the gases present in air in increasing order of their boiling points. What do you observe?
- Which gas forms the liquid first as the air is cooled?

6.12 Types of pure substances

So far we have studied about mixtures example – substances whose components can be separated by physical methods. What about substance that cannot be separated further by any of the methods of separation? We call them as **pure substances**. Let us explore further about them.

Activity-10

Can we separate Sulphur and Oxygen from Copper sulphate

Take concentrated solution of copper sulphate in beaker and drop a piece of aluminum foil in it. After some time you will observe a layer of copper deposited on the aluminum foil. The solution becomes colourless. Why did this happen?

(recall activities of the chapter on **Metals and Non-metals**)

We know that a chemical reaction takes place among the copper ions present in the solution with aluminum and copper metal is separated. Does it mean that copper sulphate is a mixture? No it is not.

Here copper cannot be separated from sulphur and oxygen by any physical process. It can be separated only by a chemical reaction. Substances such as copper sulphate are called **compounds**.

Table-4 : Mixtures and Compounds

Mixtures	Compounds
1. Elements or compounds just mix together to form a mixture and no new compound is formed.	1. Elements react to form new compounds.
2. A mixture has a variable composition.	2. The composition of each new substance is always fixed.
3. A mixture shows the properties of the constituent substances.	3. The new substance has totally different properties.
4. The constituents can be separated fairly easily by physical methods.	4. The constituents can be separated only by chemical or electrochemical reactions.

We can define compounds as pure substances that can be separated into two or more components only by means of a chemical reaction.

We now have two types of pure substances

1. Compounds
2. Elements

Elements can be divided into metals, non-metals and metalloids. We have already studied properties of metals and non-metals. Can you write down the names of some elements that you know?

Elements have been used since the early days of civilisation. Metals such as iron, lead, copper, helped in the development of civilizations. For thousands of years, alchemists up to and including Isaac Newton attempted to unearth new elements, and study their properties.

Hennig Brand, a German alchemist, boiled urine to discover phosphorus in 1669. But it was not until the late 18th century that our knowledge of the elements really took off, as chemists developed new ways to purify and isolate elements.

Sir Humphry Davy, was extremely successful in discovering many elements - sodium, magnesium, boron, chlorine and many more. Robert Boyle used the term element and Lavoisier was the first to establish a useful definition of element. He defined.

An element as a basic form of matter that cannot be broken down into simpler forms by chemical reactions.

If any substance can be separated into two or more constituent parts by a chemical reaction, that substance is definitely a compound.

What do we get when two or more elements are combined? We can understand through an activity.

Activity-11

Understanding the nature of elements, compounds and mixtures

Divide the class into two groups. Give 5g of iron fillings and 3g of sulphur powder in a china dish to both the groups.

Activity for group-1:

Mix and crush iron fillings and sulphur powder. Check for magnetism in the material obtained. Bring a magnet near the material and check if the material is attracted towards the magnet.

Activity for group-2:

Mix and crush iron fillings and sulphur powder. Heat this mixture strongly in china dish on a spirit lamp till it becomes black. Remove it from flame and let the mixture cool. Check for magnetism in the material obtained. Compare the texture and colour of the material obtained by the two groups.

Now answer the following

- Did the material obtained by the two groups look the same?
- Which group has obtained a material with magnetic property?
- Can we separate the components of the material obtained?

Group-1 has carried out the activity involving a physical change. Where as group-2 examined a chemical change. The material obtained by group 1 is a mixture of two substances. i.e. iron and sulphur, which are elements.

The properties of mixture are the same as that of its constituents. The material obtained by the group 2 is a compound. On heating the two elements strongly we get compound, which has totally different properties, compared to the properties of the combining elements. The composition of a compound is the same throughout. We can also observe that the texture and colour of the compound is the same throughout its volume.

The chemical and physical nature of the matter is better understood by the following flow chart.

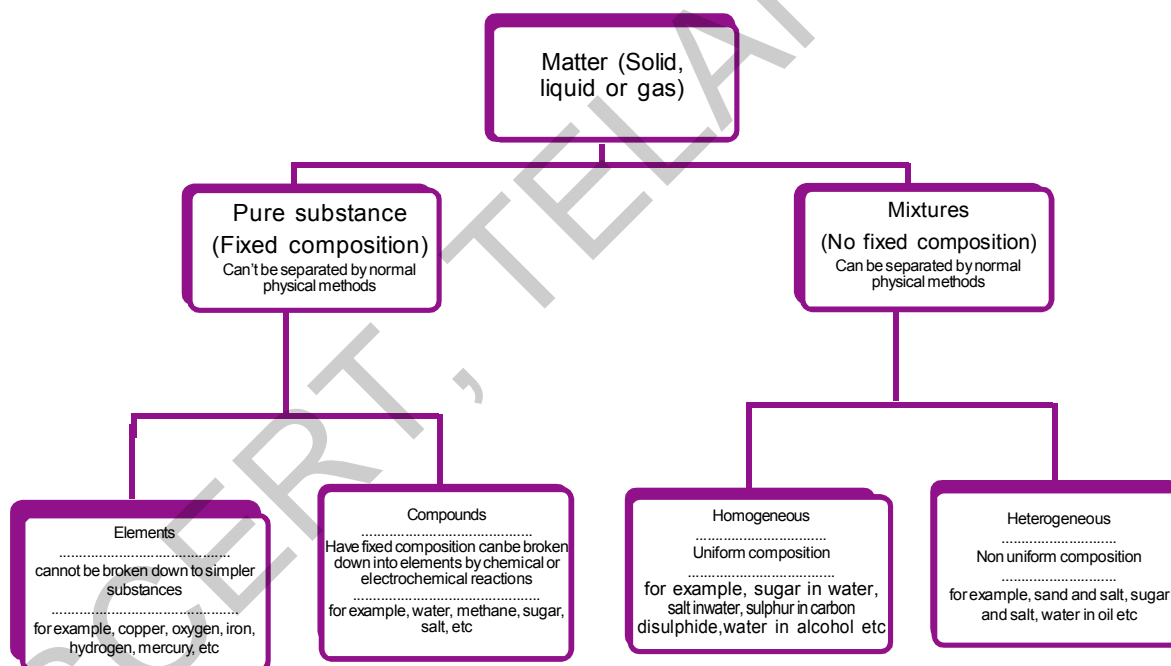

Key words

Pure substances, Mixture, Heterogeneous mixture, Homogeneous mixture, Solution, Suspension, colloids, solvent, solute, concentration of solution, Tyndall effect, Evaporation, Centrifuge, Immiscible liquids, Miscible liquids, Chromatography, distillation, Fractional distillation, Elements, Compounds. Disperse phase, dispersion medium.



What we have learnt

- A mixture contains more than one substance (element and/or compound) mixed in any proportion.
- Mixtures can be separated into pure substances using appropriate separation techniques.
- A solution is a homogeneous mixture of two or more substances. The major component of a solution is called the solvent, and the minor, the solute.
- The concentration of a solution is the amount of solute in grams present per 100 ml or per 100 g of the solution.
- Materials that are insoluble in a solvent and have particles that are visible to naked eye, is called a suspension. A suspension is a heterogeneous mixture.
- Colloids are heterogeneous mixtures in which the particle size is too small to be seen with the naked eye, but is big enough to scatter light. Colloids are useful in industry and daily life. The colloid has the dispersed phase and the medium in which they are distributed is called the dispersion medium.
- Pure substances can be elements or compounds. An element is a form of matter that cannot be broken down by chemical reactions into simpler substances. A compound is a substance composed of two or more different types of elements, chemically combined in a fixed proportion.
- Properties of a compound are different from its constituent elements, whereas a mixture shows the properties of its constituting elements or compounds.



Improve your learning



I. Reflections on concepts

1. Which separation techniques will you apply for the separation of the following? (AS₁)
 - (a) Sodium chloride from its solution in water.
 - (b) Ammonium chloride from a mixture containing sodium chloride and ammonium chloride.
 - (c) Mixture of oil and water.
 - (d) Fine mud particles suspended in water.
2. Explain the following giving examples. (AS₁)
 - (a) Saturated solution
 - (b) Pure substance
 - (c) colloid
 - (d) Suspension
3. Classify the following into elements, compounds and mixtures. (AS₁)
 - (a) Sodium
 - (b) Soil
 - (c) Sugar solution
 - (d) Silver
 - (e) Calcium carbonate
 - (f) Tin
 - (g) Silicon
 - (h) Coal
 - (i) Air
 - (j) Methane
 - (k) Carbon dioxide
 - (l) Sea water

II. Application of concepts

1. Determine the mass by mass percentage of solute concentration of a 100g salt solution which contains 20g salt? (AS₁) Ans: (20%)
2. Calculate the concentration in terms of mass by volume percentage of the solute containing 2.5g potassium chloride in 50ml of potassium chloride (KCl) solution? (AS₁)
Ans: (5%)
3. Classify the following substances in the below given table. (AS₁)
Ink, soda water, brass, fog, blood, aerosol sprays, fruit salad, black coffee, oil and water, boot polish, air, nail polish, starch solution, milk.

Solution	Suspension	Colloidal dispersion

III. Higher Order Thinking Questions

1. Use the words given below and write the steps for making tea (AS₇)
Solution, solvent, solute, dissolve, soluble, insoluble, filtrate and residue.



Multiple choice questions

1. The machine used to separate the massive particles and light particles from a mixture is []
a) Atwood machine b) Centrifuge c) Filter paper d) Separating funnel
2. Which is not formed by the physical mixing of two substances []
a) Mixture b) Compound c) Colloid d) Suspension
3. The substance which is relatively less in quantity in a solution is []
a) Solute b) Solvent c) Dispersion phase d) Dispersion medium

4. The amount of solute present in a saturated in 100g. at constant temperature is known as its []
 a) Solubility b) Concentration c) Volume percentage d) Weight percentage
5. If the quantity of solute is more in a solution then the solution is said to be []
 a) Saturated solution b) Dilute Solution
 c) Concentrated solution d) Unsaturated Solution
6. The phenomenon of scattering of a visible light by the particles of colloid is known as []
 a) Tyndall effect b) Chromotography c) Sublimation d) Reflection
7. Immiscible liquids can be separated by []
 a) Distillation process b) Fractional distillation
 c) Chromotography d) Separating funnel
8. Miscible liquids can be separated by []
 a) Distillation process b) Fractional distillation
 c) Chromotography d) Separating funnel



Suggested Experiments

1. Which of the following will show Tyndall effect? How can you observe the Tyndall effect in them?
 a) salt solution b) milk c) solution of copper sulphate d) starch solution
2. Take a solution, a colloid, and a suspension in three different beakers. Pass a light beam from the side of the beaker and test whether they show Tyndall effect or not?



Suggested Projects

1. Make a list of solids, liquids and gases from your surroundings. (These substance may be organic or chemical). Separate mixtures from them and classify them into solutions, colloids and suspensions.



In the chapter "Is matter around us pure?" we used the terms elements and compounds. You learned about the role of separation techniques in identifying elements. The pure components obtained after separation (or purification) are either elements or compounds.

In this chapter, we can use this knowledge to explain some of the observations made in previous classes like the rusting of iron rod kept outside, etc.

- Does the weight of iron rod increase or decrease, on rusting?

We notice that on burning charcoal, it leaves ash at the end.

- Where does the matter of charcoal go?
- Wet clothes dry after some time - Where does the water go?

These questions and several other similar questions fascinated scientists for many years. Burning and combustion reactions, puzzled them to a greater extent.

Recall the chapter "Metals and non-metals."

- What happens to magnesium on burning it in air ?
- What happens to Sulphur on burning it in air?
- Are the weights of the reactants and products the same or different?



Do you know?

Antoine Lavoisier (1743-1794) was a French nobleman. He made many important contributions to chemistry and some call him as the **Father of Modern Chemistry**.



Lavoisier studied combustion reactions in detail. He was able to find the masses of reactants and products accurately irrespective of their physical states. Based on his observations he proposed the **law of conservation of mass**.

In this chapter, we use the following terms frequently - elements, compounds, reactants and products. Discuss with your friends about meaning of these terms. Think of different examples for each term.

Let us carry on a lab activity to observe what will happen to weights of reactants and products during a chemical reaction.

Lab Activity

Aim: To find out the change in the mass before and after a chemical reaction.

Materials required: Lead nitrate, potassium iodide, distilled water, two conical flasks, spring balance, small test tube, retort stand, rubber cork, thread, etc.

Procedure

1. Prepare a solution of lead nitrate by dissolving approximately 2 grams of lead nitrate in 100 ml of distilled water in a 250 ml conical flask.
2. Prepare a potassium iodide solution by dissolving approximately 2 gm of Potassium iodide in 100 ml water in another conical flask
3. Take 4ml solution of potassium iodide in a small test tube from the above prepared solution.

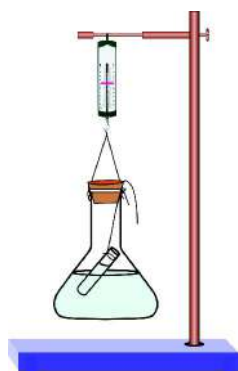

Fig - 1

4. Hang the test tube containing 4ml of potassium iodide solution in the conical flask containing lead nitrate solution carefully, without mixing the solutions. Close the flask with a cork.(see fig.- 1)
5. Weigh the flask with its contents carefully using spring balance.
6. Now tilt and swirl the flask, so that the two solutions mix. (see fig.- 2).

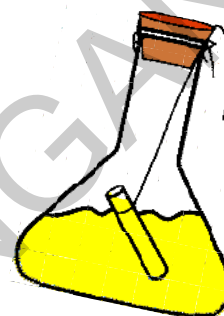

Fig - 2

7. Weigh the flask again using the same spring balance as shown in fig.- 3.

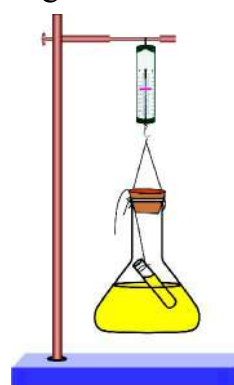

Fig - 3

8. Record your observations:
Weight of flask and contents before mixing =
Weight of flask and contents after mixing =

Now, try to answer these questions:

- Did you observe any precipitate in the reaction?
- Do you think that a chemical reaction has taken place in the flask? Give reasons.

- Do the weights, of the flask change during the activity?
- What are your conclusions?

Result:

A chemical reaction takes place and the mass remains same before and after the chemical reaction. Therefore, mass is neither created nor destroyed in a chemical reaction.



Think and discuss

- Do you get the same result if the conical flask is not closed?

7.1 Law of conservation of mass

Earlier, it was thought that mass of charcoal decreases on burning. But Lavoisier, carried out the burning of charcoal in a closed apparatus and found no change in mass.

Antoine Lavoisier on the basis of his experiment proposed the law of conservation of mass. It states that, **"Matter is neither created nor destroyed during a chemical reaction"**. More simply, **"the mass of products is equal to the mass of the reactants in a chemical reaction"**.



Think and discuss

- Recall the burning of the Magnesium ribbon in air. Do you think mass is conserved during this reaction?



Do you know?

Though the law of conservation of mass was proposed by Lavoisier, It was experimentally verified by Landolt. The experiment carried out by us is a modified form of the experiment performed by Landolt. Ask your teacher about Landolt experiment.

7.2 Law of constant proportions

From the experiments on law of conservation of mass, we saw that mass does not change during a chemical reaction.

Now let us look at the results of some experiments carried out by the **Joseph L. Proust** between 1798 and 1808.

Proust took two samples of copper carbonate - a compound of copper, carbon and oxygen. He took a sample from nature and another sample prepared in the lab and decomposed it chemically to find percentage of copper, carbon and oxygen in the two samples.

The results obtained are given in table- 1

Table-1

Element	Weight percentage	
	Natural sample	Synthetic sample
Copper	51.35	51.35
Carbon	38.91	38.91
Oxygen	9.74	9.74

- What do you observe from the table?

- Do you observe any difference in the weight percentage of copper, carbon and oxygen in two samples?

Similarly, Proust took water from different sources, and found that the weight percentage of oxygen and hydrogen was the same in all samples. There was no relation between the place from where the sample came and its composition.

Based on his experiments, Proust put forward the law of constant (or definite) proportions. It states that, "**a given chemical substance always contains the same elements combined in a fixed proportions by mass.**" This means that the relative proportion of elements in a compound is independent of the source or method of preparation.



Think and discuss

- 100 g of mercuric oxide decompose to give 92.6 g of mercury and 7.4 g of oxygen. Let us assume that 10 g of oxygen reacts completely with 125 g of mercury to give mercuric oxide. Do these values agree with the law of constant proportions?
- Discuss with your friends if the carbon dioxide that you breathe out and the carbon dioxide they breathe out are identical. Is the composition of the carbon dioxide of different sources same?

Why are the laws valid?

By early 19th century, the scientists knew some laws governing chemical

reactions. Why are these laws valid? Why can't the elements combine in any arbitrary proportion ?

Many scientists tried to give appropriate explanations. The English school teacher **John Dalton** proposed the basic theory about the nature of matter. Dalton reasoned his proposals as mentioned below.

1. If mass was to be conserved, then all elements must be made up of extremely small particles, called atoms.
2. If law of constant proportion is to be followed, the particles of same substance can not be different.

Based on the above laws, Dalton proposed "a new system of Chemical Philosophy".

Dalton's atomic theory

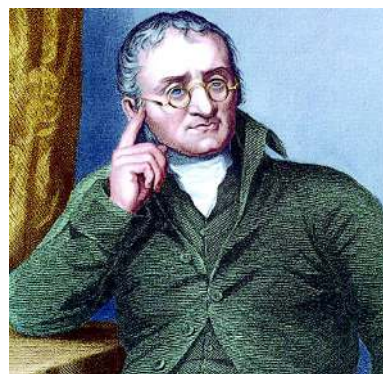

John Dalton

Postulates of Dalton's Atomic theory :

1. Matter consists of indivisible particles called atoms.
2. Atoms are neither created nor destroyed in a chemical reaction. Reorganisation of atoms occur in chemical reactions.
3. All the atoms of an element have identical mass and identical chemical properties.

Atoms of different elements have different masses and different chemical properties.

- Compounds are formed when atoms of different elements combine in simple whole number ratios. That is, chemical change is the union or separation of atoms as in whole numbers.
- When atoms of different elements combine in different whole number of ratios they form different compounds. eg : carbon monoxide (CO); carbon dioxide (CO₂). Hence 'C' and 'O' combine in 1:1 and 1: 2 ratios respectively to give two different compounds



Think and discuss

- Which postulate of Dalton's theory is the result of the law of conservation of mass?
- Which postulate of Dalton's theory can explain the law of constant proportions?



Do you know?

About 2600 years ago, an Indian sage (*Rishi*) called *Kanada* also postulated atoms in his *VAISHESIKA SUTRA*. The actual name of *Kanada* was *Kasyapa* - he was renamed after his *KANA SIDHANTHA*. He proposed that all forms of matter are composed of very small particles known as **anu** and each anu may be made up of still smaller particles called **parmanu**.

The word 'atom' is derived from a Greek word 'a-tomio' (means- indivisible)

7.3 Atoms and molecules

Very often you may have heard that atoms are the building blocks of all matter. But what does it mean? It means that matter is composed of tiny particles known as atoms.

These atoms are so small that we cannot see them even with a high-powered microscope. The number of atoms present even in a small amount of matter is very large.



Do you know?

The aluminium foil that we use to pack food might seem thin to you. But it has atoms in lakhs, along with its thickness.

- Are elements also made of atoms?

We know that substances are made up of atoms or molecules. Atoms are the most fundamental of all particles that can have an independent existence. Sometimes two or more atoms combine to form a big particle. When atoms combine, they form **molecules**. When the particles of a substance contain only one type of atoms, that substance is called an **element**. In elements the smallest particle may be atom or molecule.

There are many elements whose smallest particle is an atom. Iron, copper, zinc,

aluminium, silver, gold, etc are examples of substances in which the smallest particle is an atom.

Oxygen and nitrogen are examples of substances in which the particles are a combination of two identical atoms. The smallest particles of elements that are stable are known as molecules. For example one sodium molecule has one sodium atom but one oxygen molecule has two oxygen atoms.

Atoms of same elements or of different elements can join together to form molecules. If atoms of different elements join together, they form a new substance known as **compound**. So we can have molecules of elements and molecules of compounds. A **molecule** can be defined as the smallest particle of a substance that has independent existence and retains all the properties of that substance.

7.4 Why do we name elements?

Do you know what gold is called in your language? But in other languages it would have a different name. There are so many languages in the world that it is not possible to know the different names of each element in different languages. To help scientists communicate without confusion, we must have one name for each element that is accepted by everyone.



Do you know?

How elements like hydrogen and oxygen got their names?

Sometimes elements are named based on their property. For example, the Latin word for water is '**hydro**'. So the element that combined with oxygen to give water was named hydrogen. At one time people believed that any substance that reacts with oxygen would be acidic in nature. The Latin word for acid is '**oxy**'. Hence the gas was called oxygen, meaning 'gas that forms acid'. It was later discovered that the acidic property was not related to oxygen. However, by then the name had come into common use so it was not changed. Place of discovery of element can also play a role in its naming. For example, the gas which was first discovered in the sun (Greek name for Sun is '**helio**'), was named helium. Can you guess the origin of names of polonium and californium?

Sometimes elements were named to honour the scientists. For example: Einsteinium, Fermium, Rutherfordium and Mendelevium.

7.5 Symbols of elements

You must have realized that chemistry involves a lot of reactions. It will be a waste of time to write the full name of the elements and compounds every time to describe a reaction. To avoid this we use

some shortcuts. Using short forms or symbols for naming the elements is one solution.

Do you know?



John Berzelius suggested that initial letter of an element from its name in English written in capitals should be the symbol of that element, Eg. 'O' for oxygen, 'H' for Hydrogen and so on.

Over a 118 elements have been discovered so far. How do we decide their symbols?

Table-2: Symbols for some elements

Element Name	Symbol
Hydrogen	H
Oxygen	O
Nitrogen	N
Sulphur	S
Carbon	C
Calcium	Ca
Chlorine	Cl
Chromium	Cr
Boron	B
Barium	Ba
Bromine	Br
Beryllium	Be
Aluminium	Al
Iron	Fe
Gold	Au
Sodium	Na
Potassium	K

Usually, the first letter of the name of the element in English becomes the symbol of that element and is always written as a capital letter (upper case).

How do we write the symbols for Calcium, Chlorine, Chromium? We have already used the letter 'C' for Carbon. Look at the elements after Carbon and before Aluminium in the table. Discuss with your teacher and friends how the symbols have been decided for these elements.

Notice the following:

- A symbol can have either one or two letters of English.
- The first letter of the symbol is always upper case and the second letter is always lower case.

Activity-1

Some elements and their possible symbols are given in table-3. Correct them and give reasons for your corrections.

Table-3

Element	Possible symbol
Aluminium	al
Carbon	c
Chromium	Chr
Chlorine	CL
Beryllium	Be

7.6 Some unusual symbols

This is not the end of the problem. We observe that symbols for some elements come from their names but some don't, which can be seen in Table-4. Certain elements have symbols based on their Latin names (or older names in other languages).

- Would you be able to recognise the elements of the table-2, have symbols of this category?

Activity-2

Write the symbols for given elements

Look at a periodic table and try to find the symbols for the given elements in table 4 and write them against their names.

Table-4

Element	Sodium	Silver	Tungsten	Potassium	Copper	Gold	Iron	Lead	Mercury
Latin/German name	Natrium	Argentum	Wolfram	Kalium	Cuprum	Aurum	Ferrum	Plumbum	Hydrargyrum
Symbol									

7.7 Elements with more than one atom in their molecules

We have learnt that several elements have more than one atom in their smallest constituent particles. It means these elements contains two or more atoms combined together to form a molecule. Oxygen, hydrogen and nitrogen are examples of such elements.

For example, a molecule of oxygen has two atoms. We need a formula to represent such a molecule in a simple way. The formula for oxygen molecule is O_2 . Why don't we write it as $2O$? Writing a formula in this way indicates two separate atoms of oxygen. Hence first write the symbol for oxygen, and then write 2 as a subscript after the letter O.

Subscript number indicates number of atoms of Oxygen combined to form its molecule. You might have heard about Ozone gas. This gas is found in large quantities in the upper layers of the earth's atmosphere. It protects us by shielding the earth from harmful ultra violet rays of the sun. Every molecule of ozone has three atoms of oxygen. Can you write the formula of ozone?

7.7.1 Atomicity

Molecules of many elements, such as Argon (Ar), Helium(He), etc are made up of only one atom of that element. But this is not the case with the most of non metals. In non metals the molecules contain more than two atoms of same element.

The number of atoms constituting a molecule is known as its **atomicity**.

For example, a molecule of hydrogen consists of two atoms of hydrogen. Here the atomicity is two; hence it is known as diatomic molecule. Helium (He), Argon(Ar) exist as single atom. Hence

they are known as monoatomic.

Observe the following table to know atomicity of molecules of few elements and try to write the symbol of molecule based on its atomicity.

Table-5

Name of the element	Formula	Atomicity
Argon	Ar	Monoatomic
Helium		Monoatomic
Sodium	Na	Monoatomic
Iron		Monoatomic
Aluminium		Monoatomic
Copper		Monoatomic
Hydrogen	H ₂	Diatomic
Oxygen		Diatomic
Nitrogen		Diatomic
Chlorine		Diatomic
Ozone	O ₃	Triatomic
Phosphorus		Tetratomic
Sulphur	S ₈	Octatomic

- Why do some elements be monoatomic?
- Why do some elements form diatomic or triatomic molecules?
- Why do elements have different atomicities ?

To understand the atomicities of molecules of elements and compounds

we need to understand the concept of valency.

- What is valency?

7.7.2 Valency

Till now, there are over 118 elements known. These elements react with each other to form compounds.

Table-6
Valencies of some elements

Element	Valency
Helium	0
Hydrogen	1
Fluorine	1
Chlorine	1
Oxygen	2
Nitrogen	3
Carbon	4

Every element has a definite combining capacity, that determines the atomicity of its molecules. Every element reacts with atoms of other element according to its combining capacity number. This combining capacity number is called valency. So atoms of the elements have power to combine with atoms of other elements. This is known as its valency.

7.8 What is an ion?

Compounds formed by metals and non metals contain charged particles. The charged particles are known as ions. A negatively charged ion is called anion and the positive charge ion is cation.

For example sodium chloride does not contain discrete molecules as its constituent units. Its constituent particles are positively charged sodium ions (Na^+) and negatively charged chloride ions (Cl^-).

Ions may be a charged independent atoms or a group of atoms (polyatomic) that have a net charge on them. Hence ions are charged particles.

Table-7: Some common, simple and poly atomic ions.

Net Charge	Cation	Symbol	Anion	Symbol
1 unit	Hydrogen	H^+	Hydride	H^-
	Sodium	Na^+	Chloride	Cl^-
	Potassium	K^+	Bromide	Br^-
	Silver	Ag^+	Iodide	I^-
	Copper (Cuprous)*	Cu^+	Hydroxide	OH^-
	Ammonium	NH_4^+	Nitrate	NO_3^-
2 units	Magnesium	Mg^{+2}	Oxide	O^{-2}
	Calcium	Ca^{+2}	Sulphide	S^{-2}
	Zinc	Zn^{+2}	Sulphate	SO_4^{-2}
	Copper (cupric)*	Cu^{+2}	Carbonate	CO_3^{-2}
	Iron (Ferrous)*	Fe^{+2}	Dichromate	$\text{Cr}_2\text{O}_7^{-2}$
3 units	Aluminium	Al^{+3}	Nitride	N^{-3}
	Iron(Ferric)*	Fe^{+3}	Phosphate	PO_4^{-3}

* elements which show variable valency.

Valency of an ion is equal to the magnitude of its charge. For Example valency of chloride ion (Cl^-) is 1. Valency of sulphate ion (SO_4^{-2}) is 2.

Now refer the table-7 and try to write the valencies of some other ions.

7.9 Atomic mass

The most remarkable concept that Dalton's atomic theory proposed was "atomic mass". According to him each element had a characteristic atomic mass.

Since, atoms are extremely light and small, scientists find it difficult to measure their individual masses. Hence, the mass of an atom is compared with a standard atomic mass of some other element.

In 1961, it was universally accepted that mass of carbon-12 atom would be used as a standard reference for measuring atomic masses of other elements.

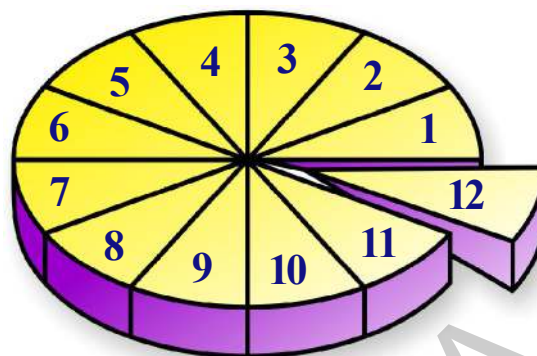

Fig - 4

Observe the diagram (fig-4). Let us assume the circle in the diagram represents atomic mass of carbon-12. It is divided into 12 equal parts as shown in the fig-4, and each part represents $\frac{1}{12}$ of atomic mass of carbon-12.

One atomic mass unit (amu) is defined as the mass exactly one twelfth of the atomic mass of Carbon-12 isotope.

The number of times one atom of given element is heavier than $\frac{1}{12}$ th of atomic mass of carbon-12 is called its **atomic mass**.

The atomic mass of an element is defined as the average mass of all the isotopes of the element as compared to $\frac{1}{12}$ th of the mass of one carbon -12 atom.

Table-8: Atomic masses of a few elements

Element	Atomic Mass (in u)	Element	Atomic Mass (in u)
Hydrogen	1	Aluminium	27
Carbon	12	Phosphorus	31
Nitrogen	14	Sulphur	32
Oxygen	16	Chlorine	35.5
Sodium	23	Potassium	39
Magnesium	24	Calcium	40

Atomic mass of an element is a ratio. Hence it has no units, but it is expressed in **amu**. According to latest IUPAC (International Union of Pure and Applied Chemistry) recommendations the **amu** has been replaced by 'u', which is known as **unified mass**.



Do you know?

1. Atomic weights of elements were determined in the beginning with reference to hydrogen by John Dalton.

While searching various atomic mass units scientists initially took 1/16th of the mass of an atom of naturally occurring oxygen as a unit. This was considered relevant due to two reasons.

- Oxygen reacted with a large number of elements and formed compounds.
- This atomic mass unit gave masses of most of the elements as whole numbers.

2. During nineteenth century there were no facilities to determine the mass of an atom. Hence, chemists determined the mass of one atom relative to another by experiments. Today, atomic mass of an atom can be determined very accurately with the help of an instrument called mass spectrometer.

7.10 Molecules of compounds

A molecule may contain one or more atoms. A molecule may be formed by the combination of atoms of same element or

different elements. For example, a molecule of water is formed by the combination of two atoms of hydrogen and one atom of oxygen. All the molecules of water are identical.

Is it possible for any number of atoms of hydrogen to combine with any number of atoms of oxygen to form a molecule of water? For all the molecules of water to be identical, it is essential that the atoms of hydrogen and oxygen that are present in the molecule must be in fixed numbers. If this number is not fixed, how could all the particles of water be identical?

Each molecule of water contains 2 atoms of hydrogen and 1 atom of oxygen.

7.10.1 Chemical formulae of compounds

Compounds is denoted by formula. While writing the formula of a compound we must keep two things in mind. First, we must see the elements present in a molecule of the compound. Second, we must see the number of atoms of each element present in that molecule. 2 atoms of hydrogen and one atom of oxygen are present in a molecule of water, its formula is H_2O .

Another rule is that if the molecule of a substance contains only one atom, subscript need not be written in the formula.

Now look at another example. A molecule of carbon dioxide contains one atom of carbon and two atoms of oxygen. carbon and oxygen also react to form another compound called carbon monoxide. A molecule of carbon monoxide contains one atom of carbon and one atom of oxygen.

- Can you write the formula of carbon dioxide and carbon monoxide? Try to write formula for them as we have done in case of water molecule.

Let us try to write chemical formulae of compound in **criss - cross method** by using valency.

Criss - Cross Method

The following steps should be taken while writing the chemical formula of sodium carbonate.

1. Write the symbols of each atom or group of atoms side by side, usually the cation first and anion next -
Na CO₃
2. Write the valency of each atom or group of atoms at the top of its symbol Na¹ (CO₃)²
3. Divide the valency numbers by their highest common factor if any to get the simple ratio. Na¹ (CO₃)²
4. Inter change the valency and write the numbers as the subscript to right side of the constituents as their subscripts. Na₂(CO₃)₁
5. If any constituent receives the number 1, ignore it while writing the formula.
6. If a constituent has more than one atom, enclose it with in brackets, if it carries 2 or more mention as subscripts. [Look at the formula of aluminium sulphate].

Hence the formula for the sodium carbonate is Na₂CO₃.

Examples

1. Formula of hydrogen chloride

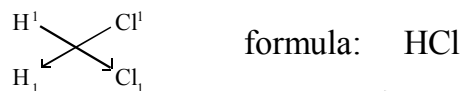

2. Formula of magnesium chloride



3. Formula of calcium oxide



4. Formula of aluminium sulphate is



Table-9: Formulae of some compounds

Compound	Formula
Sodium Carbonate	Na ₂ CO ₃
Sodium bicarbonate	NaHCO ₃
Sodium hydroxide	NaOH
Copper Sulphate	CuSO ₄
Silver Nitrate	AgNO ₃
Hydrochloric Acid	HCl
Sulphuric Acid	H ₂ SO ₄
Nitric Acid	HNO ₃
Ammonium Chloride	NH ₄ Cl
Potassium Dichromate	K ₂ Cr ₂ O ₇
Potassium Permanganate	KMnO ₄

7.11 Molecular mass

We have already discussed the concepts of atomic mass. This concept can be extended to calculate molecular masses.

The molecular mass of a substance is the sum of the atomic masses of all the atoms present in a molecule of the substance. As atomic mass is a relative, it is therefore the molecular mass is also relative. Mass of a molecule is expressed in unified Mass (u).

For Example: calculate the molecular mass of H_2SO_4

Solution

$2(\text{atomic mass of hydrogen}) + (\text{atomic mass of sulphur}) + 4(\text{atomic mass of oxygen}) = (2 \times 1) + 32 + (4 \times 16) = 98 \text{ u}$

7.11.1 Formula unit mass

One formula unit of NaCl , means one Na^+ (Sodium ion) and one Cl^- (Chlorine ion), similarly one formula unit of MgBr_2 means one Mg^{2+} ion and two Br^- ions, and one formula unit of H_2O means one H_2O molecule. The formula unit mass of a substance is a sum of the atomic masses of all atoms in a formula unit of a compound. Formula unit mass is calculated in the same manner as the molecular mass. The only difference is that formula unit is used for the substances whose constituents particles are ions. Sodium Chloride has a

formula unit NaCl . The formula unit mass can be calculated as:

$$1 \times 23 + 1 \times 35.5 = 58.5 \text{ u}$$

7.11.2 Mole concept

We have learnt that atoms and molecules are extremely small in size and their number is really very large. Even in a small amount of any substance we find very large number of atoms or molecules.

How many molecules are there in 18 grams of water?

How many atoms are there in 12 grams of carbon?

You will be surprised to know that the number of molecules in 18 grams of water and no. of atoms in 12 grams of carbon are the same. This number is very large. To handle such large numbers, a unit called mole is introduced. This is a numerical quantity.

One mole of a substance is the amount of the substance which contains as many particles (atoms, molecules, ionsetc) or entities that are equal to the atoms present in exactly 12 grams of ^{12}C isotope.

The number of particles (atoms or molecules) present in one mole of any substance has a fixed value of 6.022×10^{23} . This is experimentally calculated value.

This number is called Avogadro constant (N_A) named in honour of the Italian scientist, Amedeo Avogadro.



Do you know?

The word "mole" was introduced by Wilhelm Ostwald, who derived the term from the latin word "moles" meaning a 'heap' or 'pile'. A mole substance may be considered as a heap of atoms or molecules. The unit mole was accepted in 1967 to provide a simple way of reporting a large number-the massive heap of atoms and molecules in a sample.

7.11.3 Molar mass

Having defined mole, it is easier to know the mass of 1 mole of substance. The mass of 1 mole of a substance which is expressed in grams is called its molar mass. The molar mass and molecular mass are numerically equal but molar mass has units grams and molecular mass has unified mass units.

For example molecular mass of water (H_2O) = 18u. Molar mass of water = 18 g

18 u water has only one molecule of water. But 18 g water has one mole molecules of water that is 6.022×10^{23} molecules.

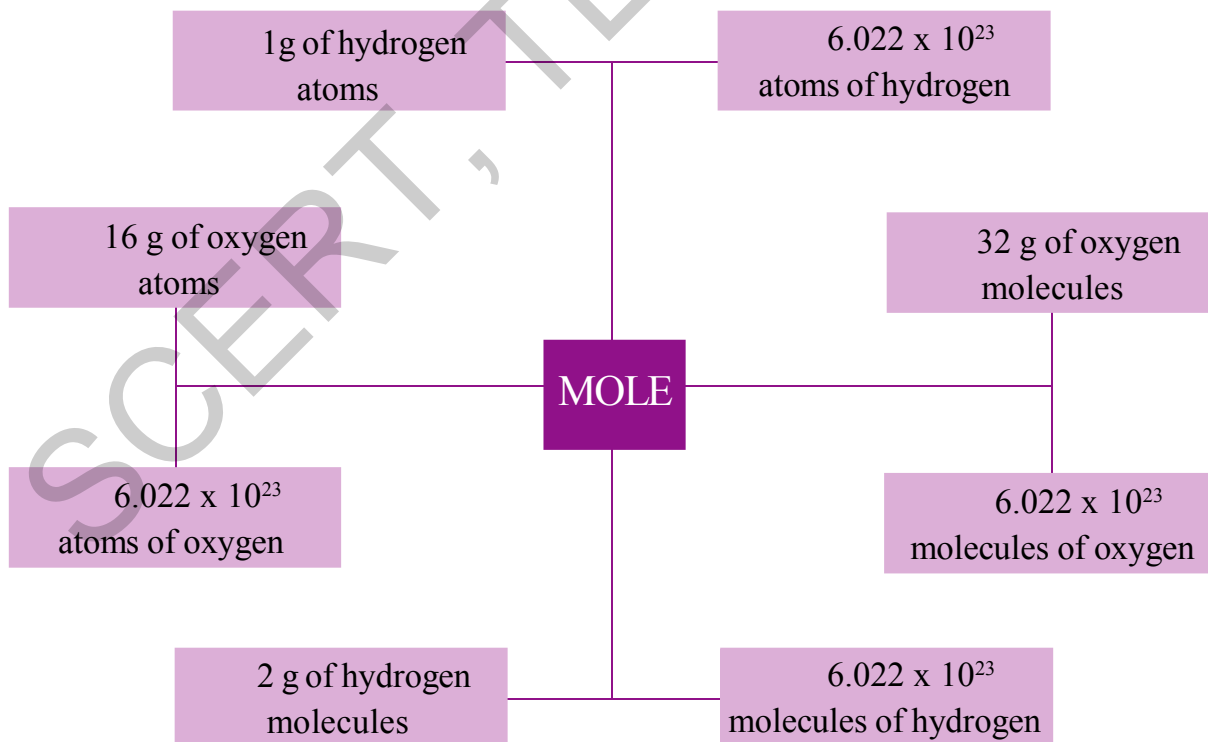

Fig-5: Diagram on concept of mole

7.12 Chemical Reactions

We have learnt about elements, molecules and compounds. We also learnt symbols and formulae of some elements and molecules. We know how to write formula to a compound.

- Have you observed occurring different colours when fire crackers are burnt?
- Have you observed the changes when a piece of plastic is burnt?
- Have you observed the change in colour of litmus paper when dipped in acid or base?

These changes are called chemical changes. The chemical substances which are participating in chemical reaction are called reactants and the new substances formed are called products.

Why these changes are occurring?

In chemical reactions atoms are neither created nor destroyed. A chemical reaction is a process that is usually characterized by a *chemical change* in which the starting materials (reactants) are different from the products. Chemical reactions occur with the formation and breaking of *chemical bonds*. (you will learn about chemical bonding in class 10).

These chemical reactions are classified into four types based on the way that chemical reaction takes place. Let's learn them doing a few activities.

7.13 Types of Chemical Reactions

7.13.1 Chemical Combination

Activity 3

(This activity needs Teacher's assistance)

- Take a small piece (about 3 cm long) of magnesium ribbon.
- Rub the magnesium ribbon with sand paper.
- Hold it with a pair of tongs.
- Burn it with a spirit lamp or burner.
- What do you observe?

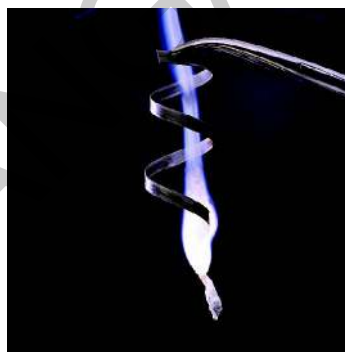
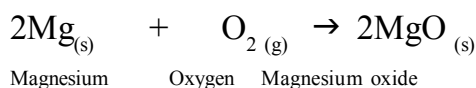

fig-6: Burning of magnesium ribbon

You will notice that, magnesium burns in oxygen by producing dazzling white flame and changes into white powder. The white powder is magnesium oxide.



In this reaction magnesium and oxygen combine to form a new substance magnesium oxide. A reaction in which single product is formed from two or more reactants is known as *chemical combination reaction*.

You will also notice release of enormous amount of heat energy when magnesium is burnt in air.

Let us discuss some more examples of combination reactions.

- (i) Burning of Coal: When coal is burnt in oxygen, carbon dioxide is produced.

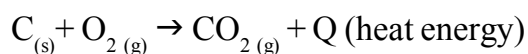
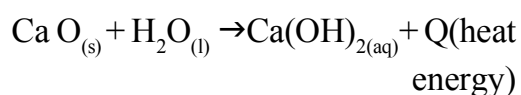

fig-7: Formation of slaked lime by the reaction of CaO with water

- (ii) Slaked lime is prepared by adding water to quick lime.



Large amount of heat energy is released on reaction of water with $CaO_{(s)}$.

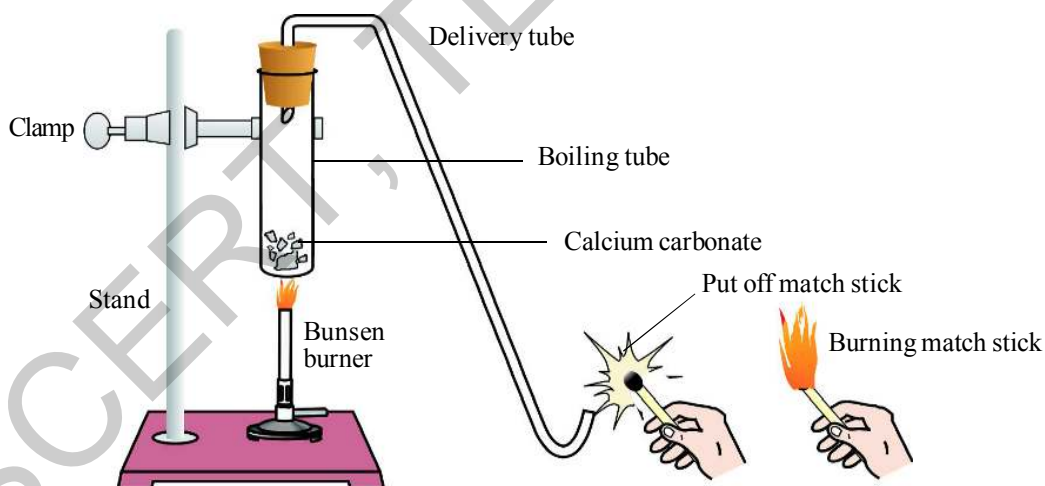

fig-8: Heating of calcium carbonate and testing the gas evolved with burning match stick

- Heat the boiling tube over the flame of spirit lamp or burner.
- Now bring a burning match stick near the evolved gas as shown in the figure.
- What do you observe? You will notice that match stick would be put off. Why do you think so? Which gas is evolved?

If you touch the walls of the container you will feel the hotness. Such reactions are called **exothermic** reactions.

A solution of slaked lime produced in the reaction equation (ii) is used to white wash the walls. Calcium hydroxide reacts slowly with the carbon dioxide in air to form a thin layer of calcium carbonate on the walls. It gives a white shiny finish to the walls.

7.13.2 Decomposition Reaction

Activity 4

- Take a pinch of calcium carbonate (lime stone) in a boiling tube.
- Arrange the apparatus as shown in figure 8.

- Take two test tubes filled with water and invert them over the two graphite electrodes.
- Switch on the current and leave the apparatus undisturbed for some time.
- What do you observe in the test tubes?

You will notice the liberation of gas bubbles at both the electrodes. These bubbles displace the water in the test tubes. Is the volume of gas collected in both the test tubes same? Once the test tubes are filled with gases take them out carefully.

Test both the gases separately by bringing a burning candle near the mouth of each test tube.

- What do you observe in each case?
- Can you predict the gas present in each test tube?

In the above activity on passing the electricity, water dissociates to hydrogen and oxygen. This is called electrolytic decomposition reaction.

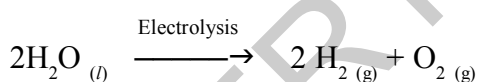

Activity 7

- Take some quantity of silver bromide on a watch glass.
- Observe the colour of silver bromide.
- Place the watch glass in sunlight for some time.
- Now observe the colour of silver bromide.
- What changes do you notice?

- Did the colour of the silver bromide change?

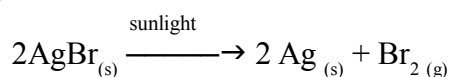

fig-11(a): Silver bromide (light yellow colour)



fig-11(b): when exposed to sunlight (gray colour) silver metal

Silver bromide decomposes to silver and bromine in sunlight. Light yellow coloured silver bromide turns to gray due to sunlight.



This decomposition reaction occurs in presence of sunlight and such reactions are called *photochemical reactions*.

All the above decomposition reactions require energy in the form of heat, light or electricity for converting the reactants to products. All these reactions are endothermic.

Carry out the following Activities:

- Take 2gms of AgCl in a watch glass. Keep it in sunlight for some time and observe the change.
- Take 1gm ferrous sulphate crystals in a boiling tube. Heat it over spirit lamp. What do you observed.

- iii) Take about 2 gm of barium hydroxide in a test tube. Add about 1 gm of ammonium chloride and mix with glass rod. Touch the test tube with your palm.

What do you observe?

7.13.3 Displacement reaction

In displacement reaction one element displaces another element from its compound and takes its place there in. Displacement of hydrogen from acids by metals: Generally metals which are more reactive than hydrogen displace it from an acid.

Let us observe the reaction in following activity.

Activity 8

- Take 1 gram of zinc dust in a conical flask.
- Add dilute hydrochloric acid slowly.
- Now take a balloon and tie it to the mouth of the conical flask.
- Closely observe the changes in the conical flask and balloon.
- What do you notice?



fig-12(a)

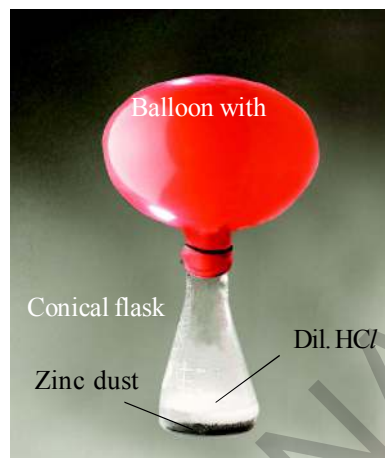
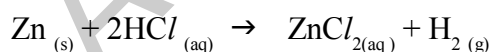

fig-12(b)

You can see the gas bubbles coming out from the solution and the balloon bulges out (fig.-12b). Zinc pieces react with dilute hydrochloric acid and liberate hydrogen gas as shown below.



In the above reaction the element zinc has displaced hydrogen from hydrochloric acid. This is displacement reaction.

Activity 9

- Take two iron nails and clean them by rubbing with sand paper.
- Take two test tubes and mark them as A and B.
- Take about 10ml of copper sulphate solution in each test tube. Dip one iron nail in copper sulphate solution of test tube A and keep it undisturbed for 20 minutes.
- Keep the other iron nail and test tube aside.
- Now take out the iron nail from copper sulphate solution and compare with the other iron nail that has been kept aside. (see fig13-a)

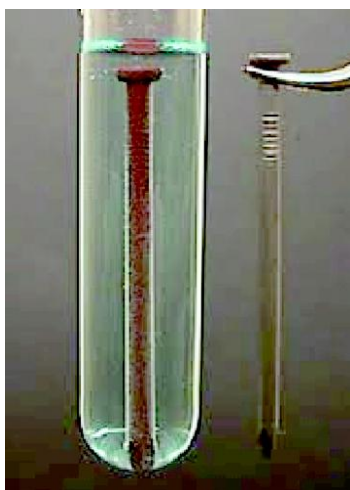

fig-13(a): Iron nail dipped in copper sulphate solution

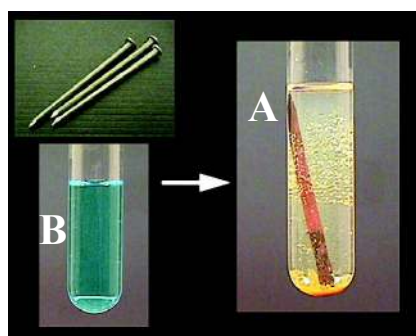
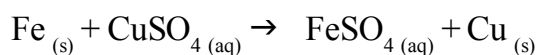

fig-13(b): Iron nail and copper sulphate solutions compared before and after the experiment

- Compare the colours of the solutions in the test tubes. (see fig13-b)
- What changes do you observe?

You will find the iron nail dipped in copper sulphate solution becoming brown. The blue colour of copper sulphate solution in test tube 'A' fades.

The chemical reaction in this activity is:



Iron is more reactive than copper, so it displaces copper from copper sulphate. This is another example of displacement reaction.

Other examples of displacement reaction are:

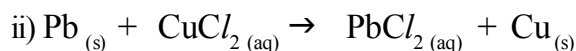
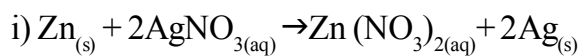

7.13.4 Double displacement reaction

Activity 10

- Take a pinch of lead nitrate and dissolve in 5.0ml of distilled water in a test tube.

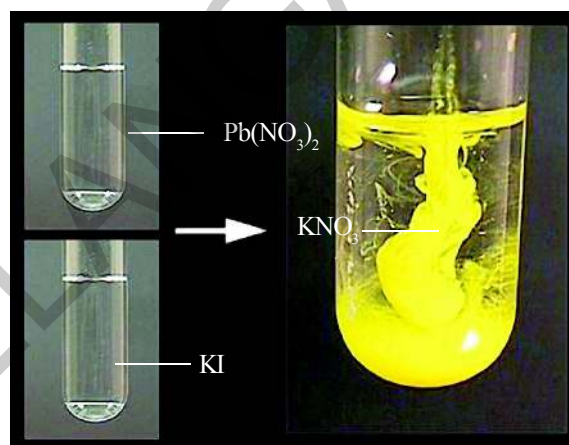
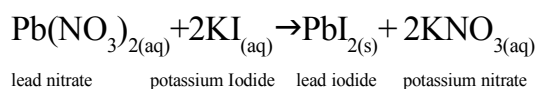

fig-14: formation of lead iodide and potassium nitrate

- Take a pinch of potassium iodide in a test tube and dissolve in distilled water.
- Mix lead nitrate solution with potassium iodide solution.
- What do you observe?

A yellow coloured substance which is insoluble in water, is formed as **precipitate**. The precipitate is lead iodide.



In the above reaction, Lead ion and Potassium ion exchanged their positions. Lead ion combined with Iodide ion to form Lead Iodide (PbI_2) precipitate and Potassium and nitrate ions formed Potassium nitrate solution (KNO_3).

This reaction is double displacement reaction. If two reactants exchange their constituents chemically and form two products, then the reaction is called as double displacement reaction.

Other examples of double displacement reactions are:

- 1) Sodium sulphate solution on mixing with barium chloride solution forms a white precipitate of barium sulphate and soluble sodium chloride.

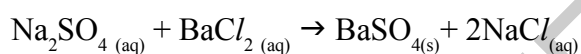

- 2) Sodium hydroxide reacts with hydrochloric acid to form sodium chloride and water.

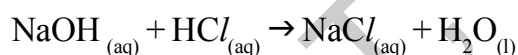

- 3) Sodium chloride spontaneously dissolves in silver nitrate solution giving silver chloride precipitate and Sodium nitrate.

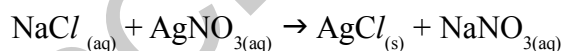

7.13.5 Oxidation and Reduction

‘Oxidation’ is a chemical reaction that involves the addition of oxygen or removal of hydrogen.

‘Reduction’ is a chemical reaction that involves the addition of hydrogen or removal of oxygen.

Let us try to understand more clearly doing this experiment.

Activity 11

- Take about 1.0g of copper powder in a china dish.
- Keep the china dish on a tripod stand containing wire gauze.
- Heat it with a bunsen burner or with a spirit lamp.
- Do you find any change in colour of copper?

You will notice that the surface layer of copper becomes black.

- Why does the colour of copper change?
- What is the black colour product formed on the surface of copper?

In the activity on heating copper it reacts with oxygen present in the atmosphere to form copper oxide.

The reaction is shown below.

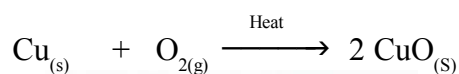

fig-15(a): Copper Oxide change into black colour

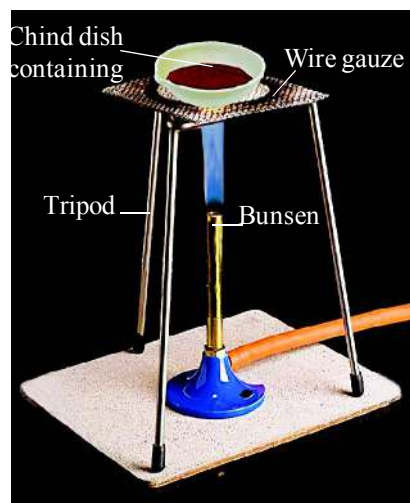

fig-15(b): Oxidation of copper to copper

Here copper combines with oxygen to form copper oxide. Here oxygen is gained and the process is called *oxidation*.

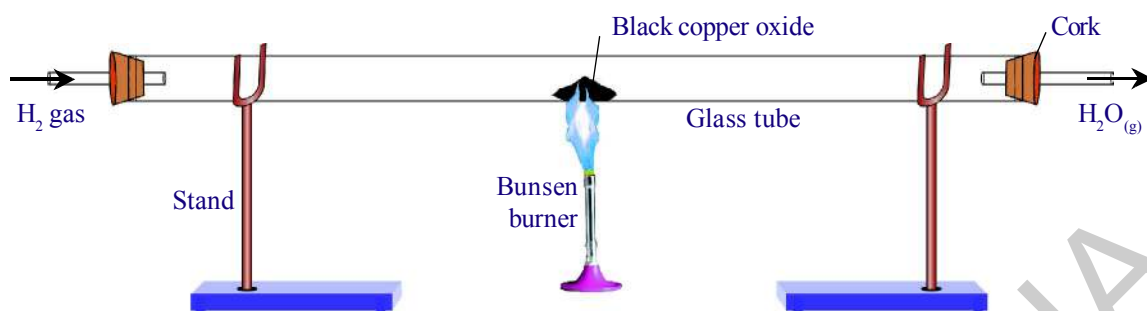
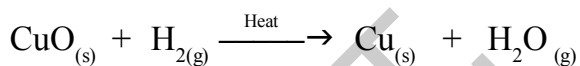

fig-16: Reduction of copper oxide to copper

Now pass hydrogen gas over hot copper oxide obtained in above activity and observe the change (see fig. 16).

- What do you notice?
- Is there any change in black colour of copper oxide?

You will notice that the black coating on copper turns brown because copper oxide loses oxygen to form copper. In this process oxygen is lost and the process is called *Reduction*.



In the above reaction hydrogen is gained; such reaction is called *reduction reaction*.

Generally oxidation and reduction occur in the same reaction. If one reactant gets oxidized, the other gets reduced. Such reactions are called *oxidation-reduction reactions or redox reactions*.

In the CuO, H₂ reaction CuO is reduced and H₂ is oxidized.

Some other examples of redox reactions are:

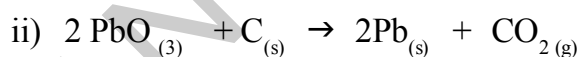

Have you observe the effects of oxidation reactions in daily life

7.14 Corrosion:

You must have observed that a freshly cut apple turns brown after some time. The shining iron articles gradually become reddish brown when left for some time. Burning of crackers produce dazzling light with white fumes.

- How do these changes occur?

They are all the examples of the process called *oxidation*.

Let us know how?



fig-17: Rusting of iron

Oxidation is the reaction of oxygen molecules with different substances starting from metal to living tissue which may come in contact with it. Apples, pears, bananas, potatoes etc., contain enzyme called polyphenol oxidase or tyrosinase, which reacts with oxygen and changes the colour on the cut surface of the fruit.

The browning of iron, when left for sometime in moist air, is a process commonly known as rusting of iron. This process is basically oxidation reaction which requires both oxygen and water. Rusting does not occur in oxygen free water or dry air.

Burning of crackers is also oxidation process of variety of chemicals, like Magnesium and Sulphur.

- Did you notice the colour coating on copper articles?

When some metals are exposed to moisture, acids etc., they tarnish due to the formation of respective metal oxide on their surface. This process is called **corrosion**.

Look at the following example:

Green coating on copper (see fig-18)



fig-18: Corrosion of copper



Corrosion causes damage to car bodies, bridges, iron railings, ships etc., and to all other objects that are made of metals. Especially corrosion of iron is a serious problem.

Corrosion can be prevented or at least minimized by shielding the metal surface from oxygen and moisture. It can be prevented by painting, oiling, greasing, galvanizing, chrome plating or making alloys. *Galvanizing* is a method of protecting iron from rusting by coating them a thin layer of Zinc.

Alloying is also a very good method of improving properties of metal. Generally pure form of iron is very soft and stretches easily when hot. Iron is mixed with carbon, nickel and chromium to get an alloy called stainless steel. The stainless steel is hard and does not rust.

A metallic substance made by mixing and fusing two or more metals, or a metal and a nonmetal, to obtain desirable qualities such as hardness, lightness, and strength is known as *alloy*.

For example: Brass, bronze, and steel.

7.15 Some more effects of oxidation on everyday life

1. Combustion is the most common example for oxidation reactions.

For example: burning of wood involves release of carbon dioxide, water vapour along with huge amount of energy.

2. Rising of dough with yeast depends on oxidation of sugars to carbon dioxide and water.
3. Bleaching of coloured objects using moist chlorine

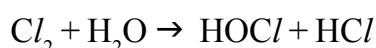

Coloured object + [O] → Colourless object.

Some times during rainy season the power supply to our home from the electric pole will be interrupted due to formation of the metal oxide layer on the electric wire. This metal oxide is an electrical insulator. On removing the metal oxide layer formed on the wire with a sand paper, supply of electricity can be restored.

4. Rancidity
- Have you ever tasted or smelt the fat/oil containing food materials left for a long time?

When fats and oils are oxidized they become rancid. Their smell and taste change.

Thus we can say that oxidation reactions in food material that were left for a long period are responsible for spoiling of food. we can say that

Rancidity is an oxidation reaction.

- How can we prevent the spoiling of food?

The spoilage of food can be prevented by adding preservatives like Vitamin C and Vitamin E.

Usually substances which prevent oxidation (Antioxidants) are added to food containing fats and oil. Keeping food in air tight containers helps to slow down oxidation process.

Manufacturers of potato chips flush bags of chips with nitrogen gas to prevent the chips from getting oxidized.



Key words

Law of conservation of mass, Law of constant proportion. Atom, Symbol, Atomic mass, Atomic mass unit (amu), Unified mass (u), Molecule, Molecules of elements, Molecules of compounds, Formula, Ion (cation, anion), Atomicity, Valency, Molecular mass, Formula unit mass, Mole, Avogadro constant, Molar mass, Chemical combination, Chemical decomposition, Displacement reaction, Double Displacement reaction, Oxidation, Reduction, Corrosion, Rancidity, Antioxidants.



What we have learnt

- The total mass of the products formed in a chemical reaction is exactly equal to the mass of the reactants. This is known as the law of conservation of mass.
- In a chemical substance the elements are always present in fixed proportions by mass. This is known as the law of constant proportion.
- An atom is the smallest particle of an element that can participate in a chemical reaction and retain all its properties.
- A molecule is the smallest particle of an element or a compound that is capable of independent existence and retains all the properties of that substance.
- Symbols represent atoms and formula represents molecules and compounds.
- Scientists use the relative atomic mass scale to compare the masses of different atoms of elements.
- The number of times one atom of a given element is heavier than $1/12^{\text{th}}$ part of mass of carbon-12 atom is called its atomic mass.
- By using criss-cross method we can write the chemical formula of a compound.
- The number of particles present in one mole of any substance is called Avogadro constant (N_A). It is a fixed value of 6.022×10^{23} .
- Mass of one mole of a substance is called its molar mass.
- In a combination reaction two or more substances combine to form a new single substance.
- In a decomposition reaction a single substance decomposes to give two or more substances.
- Reactions in which heat energy is absorbed by the reactants are endothermic reactions.
- In exothermic reaction heat energy is released by the reactants.
- A displacement reaction occurs, when an element displaces another element from its compound.
- Two different atoms or ions are exchanged in double displacement reactions.
- Oxidation is the gain of Oxygen or loss of Hydrogen.
- Loss of oxygen or gain of Hydrogen is Reduction.
- Corrosion causes damage to metal appliances.
- When fats and oils are oxidized, they become rancid.
- Precipitate is an insoluble substance.

- Write an equation for decomposition reaction where energy is supplied in the form of Heat / light / electricity. (AS-1)
- How chemical displacement reactions differ from chemical decomposition reaction? Explain with an example for each. (AS-1)
- Name the reactions taking place in the presence of sunlight? (AS-1)
- Give two examples for oxidation-reduction reaction. (AS-6)
- Draw the diagram to show the experimental setup to verify the law of conservation of mass. (AS-5)

II. Application of concepts

- Why do we apply paint on iron articles? (AS-1)
- What is the use of keeping food in air tight containers? (AS-6)

III. Higher Order Thinking Questions

- 15.9g. of copper sulphate and 10.6g of sodium carbonate react together to give 14.2g of sodium sulphate and 12.3g of copper carbonate. Which law of chemical combination is obeyed? How? (AS-1)
- Carbon dioxide is added to 112g of calcium oxide. The product formed is 200g of calcium carbonate. Calculate the mass of carbon dioxide used. Which law of chemical combination will govern your answer. (AS-1)
- Imagine what would happen if we do not have standard symbols for elements?(AS-2)



Multiple choice questions

- $$\text{Fe}_2\text{O}_3 + 2\text{Al} \rightarrow \text{Al}_2\text{O}_3 + 2\text{Fe}$$

The above reaction is an example of:

a) Combination reaction	b) Decomposition reaction
c) Displacement reaction	d) Double decomposition reaction
- What happens when dil. hydrochloric acid is added to iron filings? Choose the correct answer.

a) Hydrogen gas and iron chloride are produced.	[]
b) Chlorine gas and iron hydroxide are produced.	
c) No reaction takes place.	
d) Iron salt and water are produced.	



Which of the following statements are correct for the above chemical reaction?

- a) Lead oxide is reduced
 - b) Carbon dioxide is oxidized
 - c) Carbon is oxidized
 - d) (a) and (c) are correct
4. The chemical equation $\text{BaCl}_2 + \text{Na}_2\text{SO}_4 \rightarrow \text{BaSO}_4 + 2\text{NaCl}$ represents following type of chemical reaction. []
- a) displacement
 - b) decomposition
 - c) combination
 - d) double-displacement
5. The reaction of formation of hydrogen chloride from hydrogen and chloride represents following type of chemical reaction []
- a) decomposition
 - b) displacement
 - c) combination
 - d) double-displacement



Suggested Experiments

1. Do an experiment to understand the changes in weight of reactants and products in a chemical reaction, write a report.



Suggested Projects

1. Collect the information about the symbols, atomic weights of first thirty elements in the periodic table and write a report.



You must have noticed that some things float on the surface of the water and some things sink in it. Did you participate in the activity “floating & sinking” in the lesson on “materials” in class 6? If so, you might have wondered as to why some objects, which you expected would sink, float on water. Did you take one of those objects that floats on water, and tried to see if it floats on kerosene or coconut oil?

8.1 Have a little fun

Take a boiling tube and fill about half of it with water. Add 15 to 20 ml of kerosene to the water. Drop in, one by one, plastic buttons, pins, matchsticks, small pebbles, tiny paper balls, some sand, bits of wax etc. Close the mouth of the boiling tube and shake it well. Wait for some time and observe what happens.



Fig :1

- Did kerosene float above the water or did water float above the kerosene?
- Which objects float in kerosene?
- Which objects sink in kerosene but float on water?
- Which objects sink in water?
- Draw a diagram of the tube, showing the results of your activity.
- Why did different objects behave differently?

We shall try to find answers to these questions in this chapter.

You know that, if a glass marble and a small wooden piece are dropped in water the glass marble sinks in water but a small piece of wood floats on it. Do you know why this happens? We think that a marble sinks in water because it is heavy while the piece of wood floats, because it is light.

Now take a wooden block which is heavier than the marble and put it in water. What happens?

- Why does the wooden block float on water even though it is heavier than a marble?
- What do we mean by ‘heavy’, what do we mean by ‘light’?

To understand the results of the above activity you must understand the meaning of the term heavy. We use this word in our everyday life in two ways. We say “two kilograms of wood is heavier than one kilogram of iron”. At the same time, we also say “iron is heavier than wood”.

Can you explain the difference in meaning of the word ‘heavier’ in both these sentences? In science, we try to ensure that each word we use, has the same meaning for everyone. So let’s see in what way these two sentences differ.

The first sentence says that, if we keep two kilograms of wood in one pan of a balance and one kilogram of iron in the other, the beam of balance will tilt towards the pan with wood in it. What is the meaning of the second sentence?

In second sentence, when we say iron is heavier than wood, it means if we take a piece of iron and a piece of wood of the same size (that is, they have the same volume) and weigh them, the iron will weigh more than the wood.

In the language of science, it may be stated as “the density of iron is more than that of the wood”. Density is defined as mass per unit volume.

$$\text{Density} = \frac{\text{mass}}{\text{volume}}$$

$$\text{Units for density is } \frac{\text{gm}}{\text{cm}^3} \text{ or } \frac{\text{kg}}{\text{m}^3}$$

We therefore say, the denser object is ‘heavy’ and the less dense object is ‘light’.

8.2 Comparing density – relative density

Activity-1

Take two test-tubes of the same size. Fill one to the brim with water and the other with oil.

- Which will weigh more?
- Which liquid is denser?

Take two equal sized blocks made of wood and rubber.

- Which of these two blocks is heavier?
- Which one is denser?



Think and discuss

Let us suppose you have two blocks and you do not know what material they are made of. The volume of one block is 30 cm^3 while the other is 60 cm^3 . The second block is heavier than the first. Based on this information, can you tell which of the two blocks is denser?

When the volume of two objects is unknown, it is difficult to tell which object is denser solely on the basis of their weights. One way to compare the density of objects is to take equal volumes of the two objects and compare their weights, but this may not be possible for some solids.

For this we can use a simple method of comparing the density of each object with water. In the following activity we shall find out, how many times more dense each solid object is compared to water. This is known as relative density of that object.

$$\text{Relative density of an object} = \frac{\text{density of the object}}{\text{density of water}}$$

To find the relative density of an object, we must first weigh the object and then weigh an equal volume of water. The two weights are then compared.

Let us perform an activity to understand how this is done. But first, check your weighing instrument. We shall have to weigh objects several times, so your instrument should function properly.

 **Lab Activity 1**

Aim: Finding the relative density of different objects

Material required: Overflow vessel, 50ml measuring cylinder, weighing balance and weights or electronic weighing machine, rubber erasers, wooden blocks, glass slides, iron nails, plastic cubes, piece of aluminium sheet, glass marbles, stones, corks etc (note: whatever object you take, ensure that its volume is more than 20 cc and it should not be hollow). Record the results of your activity in table-1. (Copy this table in your note book)

Table -1

S.No.	Name of object	Weight of object	Weight of displaced water and cylinder	Weight of water displaced by the object	Relative density of the object
(1)	(2)	(3)	(4)	(5)	(6)

Weigh the 50ml measuring cylinder and note its weight here. Weight =

Procedure:

Weigh the object, record this in column 3 of the Table-1. We need to find the weight of water equal to the volume of the object. Pour water in the overflow vessel until it starts dripping from its beak. When water stops dripping from the beak, place the 50ml measuring cylinder under it. Slip the object gently into the overflow vessel as shown in fig.- 2, ensuring that

water does not splash out. Once the object is in the overflow vessel, water flows out of the beak and collects in the 50 ml. cylinder. Wait till the flow stops.



Fig-2

(The object should be fully immersed in water. If the object is not fully immersed, push it in to the water with a pin. see fig.- 2)

Weigh the cylinder with the water that overflowed and record the weight in column 4.

If we subtract the weight of the measuring cylinder from this weight, we get the weight of water (column 5 of the table-1). This is the weight of water equal to the volume of the object.

Now we can find the relative density of the object (column 6) by taking the weight of the object (column 3) and dividing it by the weight of an equal volume of water (column 5). This tells us how many times denser the object is, compared to water.

$$\text{Relative density of an object} = \frac{\text{weight of the object}}{\text{weight of water equal to the volume of the object}}$$

Find the relative densities of all objects that you collected.

Based on table-1, answer the following questions.

- What is the relative density of wood?
- What is the relative density of glass?
- Which is denser, rubber or plastic?
- Which is denser, wood or cork?
- Classify materials taken in this activity that more denser than stone and less denser than stone.
- Do objects that have a relative density less than 1 sink in water or float on it?
- Do the objects that sink in water have a relative density less than 1 or more than 1?
- What relationship do you find between the relative density of objects and floating-sinking of the objects?

One interesting aspect of relative density is that it has no units. Because relative density is a ratio of the densities of a material and water. It is a comparison of quantities having the same units, so it has no units.

8.3 Relative density of liquids

We have discussed the relative density of solid objects. We can also find the relative density of liquids. For this, we need to find the weight of a fixed volume of the liquid and the weight of an equal volume of water. The formula for finding the relative density of a liquid is:

$$\text{Relative density of a liquid} = \frac{\text{weight of the liquid}}{\text{weight of the same volume of water}}$$

(Note: Here mass and weight are considered as equivalent)

Lab Activity 2

Aim: To find the relative density of milk, groundnut oil and kerosene.

Material required: Small bottle of 50 ml. capacity (the bottle should weigh not less than 10gm), weighing balance and weights or electronic weighing machine and milk, groundnut oil, kerosene about 50 ml. each in different containers.

Procedure: Find the values given below.
 Weight of empty bottle =
 Weight of the bottle with 50ml of water
 =
 Weight of 50ml of water =
 Weigh the bottle with milk in it. Record the weight in column 3 of the Table-2.

Repeat this for other liquids and record the weights in column 3. Calculate the weight of each liquid by subtracting the weight of the empty bottle and record it in column 4. Calculate the relative density of each

liquid by comparing the weight of the liquid with the weight of same volume of water and record these values in column 5.

Table -2

S. No.	Name of liquid	Weight of the bottle filled with liquid (gm)	Weight of the liquid (gm)	Relative density of the liquid
(1)	(2)	(3)	(4)	(5)
1	Milk			
2	Coconut oil			
3	Kerosene			

Answer the following questions by comparing Table-1 and Table-2

- Which liquid will float on top if coconut oil is poured over water ?
- If we put a wooden block in kerosene, will it float or sink? Give reasons for your answer.
- A piece of wax floats in water but the same piece sinks in a liquid say liquid 'X'. Will the relative density of liquid 'X' be less than 1 or greater than 1? How can you say ?

Can we use relative density to find out whether water has been added to milk? Let's try and find out.

- If we mix some water in milk, will the relative density of the mixture be less than or more than the relative density of milk? Refer to Table-2 to find the answer.
- If we take two bottles of equal volume and pour pure milk in one and milk mixed with water in the other, which one will be heavier?

We can use a simple instrument to find this out. It is called **lactometer**.

Activity-2

Making of lactometer

Take an empty ball pen refill. It should have a metal point. Take a boiling tube and fill it with water.

Put the refill in with the metallic point inside the water as shown in fig.- 3 (The refill may not stand vertically in the water as shown in figure, it may slant and cause the top of the refill to touch the wall of the boiling tube. Think what to do to make the refill to stand as shown in fig.- 3.)

Did the refill sink completely or is some part above the water surface?

Use a pen to mark the point on the refill to show the part which is above the water surface.

Pour out the water from the boiling tube and fill it with milk. Float the refill in the milk. Did the refill sink up to the same mark as it sank in water? If not, did it sink more or less in milk than in water? Why did this happen?

Put a second mark, on the refill, at the point showing the part which is above the surface of the milk.

Now pour a mixture of milk and water in the boiling tube.

If we put the refill in this mixture, to which point will it sink? Make a guess.

Test if your guess is correct by actually dipping the refill in the milk-water mixture.

Now, are you able to test whether water is added to milk or not by using the above instrument?

We can use a similar instrument, called a hydrometer/densitometer to find out the density of any liquid.

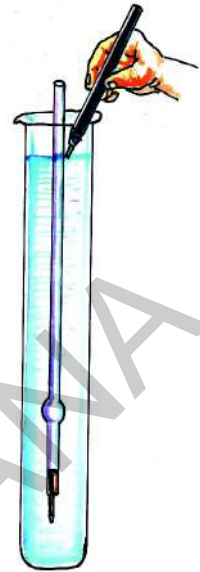

Fig -3: Improved lactometer

Example 1

What is the effective density of the mixture of water and milk when

- i) they are taken with same masses
- ii) they are taken with same volumes

Solution:

Let us say the densities of water and milk are ρ_1 and ρ_2

- i) When they are taken with same mass 'm' and their volumes are V_1 and V_2 , the

$$\text{mass of water } m = \rho_1 V_1; V_1 = \frac{m}{\rho_1} \text{ and the mass of milk } m = \rho_2 V_2; V_2 = \frac{m}{\rho_2}$$

$$\text{Total mass of water and milk is } m + m = 2m$$

$$\text{Total volume of water and milk is } V_1 + V_2 = \frac{m}{\rho_1} + \frac{m}{\rho_2}$$

$$= m \left[\frac{1}{\rho_1} + \frac{1}{\rho_2} \right]$$

$$= \frac{m(\rho_1 + \rho_2)}{\rho_1 \rho_2}$$

$$\text{The effective density of the mixture } (\rho_{\text{eff}}) = \frac{\text{Total mass}}{\text{Total volume}}$$

$$\begin{aligned}
 &= \frac{2m}{m(\rho_1 + \rho_2) / \rho_1 \rho_2} \\
 &= \frac{2}{(\rho_1 + \rho_2) / \rho_1 \rho_2} \\
 &= \frac{2 \rho_1 \rho_2}{\rho_1 + \rho_2}
 \end{aligned}$$

ii) when they are taken with same volume 'V' and their masses are m_1 and m_2

the volume of water $V = \frac{m_1}{\rho_1}$

That is $m_1 = V \rho_1$

and the volume of milk $V = \frac{m_2}{\rho_2}$

That is $m_2 = V \rho_2$

Total mass of water and milk is $m_1 + m_2 = V \rho_1 + V \rho_2$
 $= V(\rho_1 + \rho_2)$

Total volume of water and milk is $V + V = 2V$

The effective density of the mixture (ρ_{eff}) = $\frac{\text{Total mass}}{\text{Total volume}}$

$$\begin{aligned}
 \rho_{\text{eff}} &= \frac{V(\rho_1 + \rho_2)}{2V} \\
 &= \frac{1}{2}(\rho_1 + \rho_2)
 \end{aligned}$$

8.4 When do objects float on water?

Activity-3

Do objects denser than water float in it ?

Collect small objects as you did for Lab Activity 1. Place them one by one in a glass of water and observe whether they sink or float in water? Record your observations in Table-3.

Take the values of relative densities from table-1.

Table -3

Object	Relative density	Floats / Sinks
Rubber eraser		
Rubber ball		
Plastic cube		
Plastic pen		
Iron nail		
Geometry box		
Glass marble		
Wood		
Stone		

- What do you observe in the above activity?
- Why do some objects float in water though they are denser than water?
- List out the objects that float on water even though they are made up of material which is denser than water.

We know that the substances with a relative density greater than 1 sink in water. But in activity-3, we observed that substances with a relative density greater than 1 sometimes float on water.

So it seems we cannot judge whether a substance will sink or float only on the basis of its relative density. There is definitely some other factor which we need to take into account.

Let's investigate that special property, which a substance that floats has but a substance that sinks doesn't have.

In lab activity-1, we had compared the weight of the substance with the weight of the water displaced by it to find its relative density. In that activity, we immersed the substance fully in water and collected the displaced water.

We shall now do the same activity, but with a slight difference.

The substance will again be put in water. But this time, if it sinks we'll let it sink and if it floats, we'll let it float. We'll then compare the weight of water displaced by it with the weight of the substance.

Activity-4

Is the weight of an object and weight of water displaced by it equal ?

Take a beaker and weigh it. Note down its weight in your note book.

Fill water in an overflow jar. Wait until the water stops dripping from the outlet of the overflow jar. Then take the beaker from the weighing balance and place it below the outlet of the overflow jar. Take a wooden block, moisten it with water and then drop it gently into the overflow jar. Don't forcefully submerge the wooden block in the water. Also, ensure that it does not block the outlet of the overflow jar. Water will flow out of the overflow jar and collect in the beaker kept under the outlet of overflow jar.

Do you think the weight of the water displaced by the wooden block will be less than or equal to or more than the weight of the wooden block? Make a guess. Place the beaker containing the displaced water on one pan of the weighing balance. Take the wooden block, wipe it to clean off water and place it on the other pan along with the weights that equal to the weight of empty beaker as shown in Fig. - 4.

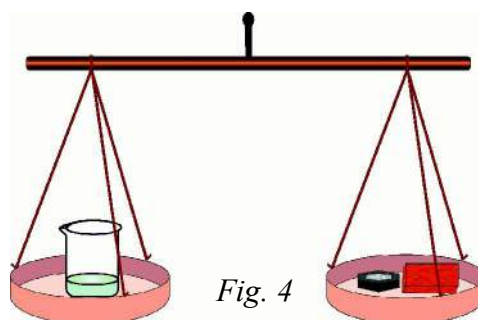

Fig. 4

- Do the two pans balance?
- Is the weight of the water displaced by the wooden block less than, equal to or more than the weight of the wooden block?

Repeat this experiment with several other substances that float or sink. Things

that float could include a plastic bowl, a ball, a steel container, fruits etc.

In each case, check whether the weight of the water displaced is less than, equal to or more than the weight of the substance. Note your observations in the table-4.

Table -4

S. No.	Name of the substance	Weight of the substance	Weight of displaced water
1	Plastic bowl		
2	Ball		
3	Steel container		
4	A fruit that floats		
5	A fruit that sinks		
6			

On the basis of the table-4, explain the relationship between the weight of the substances that float and the weight of the water displaced by them.

Can you express this special property of substances that makes the substance to float in the form of a principle?

(The special property of floating substances that you identified in this activity was first discovered by Archimedes. You will know about this further in this chapter.)

- Can you think of a way to make iron float on water? Perhaps, the following activity will give you some ideas about how you can make iron float on water.

Activity-5

Making aluminium to float

Take a small sheet of aluminium foil. Fold it four or five times, pressing the foil

tight after each fold. You already know the relative density of aluminium from an earlier Lab activity-1. With this given value of the relative density of aluminium, can you guess whether the aluminium foil will float or sink in water?

Drop the folded aluminium foil in the water and test whether your guess is correct or not.

Now unfold the aluminium foil and make it as a small bowl. Place this bowl in the water and see whether it floats or sinks.

- How much water did the bowl of aluminium foil displace?
- Is the water displaced by folded aluminium foil and bowl made using same aluminium foil the same?

Explain why aluminium bowl floats on the basis of your theory of floating substances.

- Can you now explain why large ships made of iron and steel float on water while a small block of iron sinks in water?
- Why does the metal bowl displace larger amount of water than a metal piece?

To know this you must understand the pressure in fluids.

8.5 Upward force in liquids

When we put an object on the surface of water in a container, the force of gravity, exerted by the Earth, pulls the object downwards i.e. towards the bottom of the container. However, for objects that float on water, there must be an upward force to balance the force of gravity. This upward force must come from water. If the gravitational force on the object is more than the upward force of water, the object will sink in water. Let us do a simple activity to observe this upward force.

Activity-6

Observing the upward force of liquids

Take an empty plastic bottle. Put the cap on it tightly. Place the bottle in a bucket of water. The bottle will float.

Push the bottle into the water by your hand as shown in fig.- 5.

Do you feel an upward force? Try to push it further down. Do you feel any increase in the upward thrust? In fact, the

upward force of water keeps on increasing as you try to push the bottle down. Now, release the bottle and observe how it bounces back to the surface of water!



Fig. 5

So the upward force of water is a real, observable force (Buoyancy). This force acting on unit area of the surface of an object (bottle) is called static pressure of the water.

Pressure of Air

Activity -7

Observing air pressure

Take a glass tumbler. Stick some cotton at the bottom of it. Immerse it inversely in water up to the bottom of the container as shown in fig.- 6.



Fig. 6

Take out the tumbler from water. Is the cotton attached to its bottom wet? Why? This is due to the force of air which is applied on water by the air present in the tumbler and stops water from entering the tumbler. This force on unit area of water is pressure of air.

Atmospheric pressure

All objects on the surface of the earth are subject to constant atmospheric pressure.

$$\text{Atmospheric pressure} = \frac{\text{Force of the atmosphere}}{\text{surface area of the earth}} = \frac{F}{A}$$

$$\text{Atmospheric pressure} = \frac{\text{Weight of the atmosphere}}{\text{surface area of the earth}} = \frac{w}{A}$$

$$\text{Atmospheric pressure} = \frac{(\text{Mass of the atmosphere}) \times g}{(\text{surface area of the earth})} = \frac{m \times g}{A}$$

$$\begin{aligned} \text{Atmospheric pressure} &= \frac{(\text{average density of the atmosphere}) \times (\text{Volume of the atmosphere}) \times g}{(\text{surface area of the earth})} \\ &= \frac{\rho \times v \times g}{A} \end{aligned}$$

$$\begin{aligned} \text{Thus Atmospheric pressure} &= \frac{\rho \times \text{surface area of the earth} \times \text{Height of the atmosphere} \times g}{\text{surface area of the earth}} \\ &= \frac{\rho \times A \times h \times g}{A} \end{aligned}$$

$$\text{Atmospheric pressure} = \rho \times (\text{Height of the atmosphere}) \times g = \rho \times h \times g$$

$$\begin{aligned} \text{Atmospheric pressure} &= \rho h g \\ P_0 &= \rho h g \end{aligned}$$

8.6 Measuring atmospheric pressure

We do not directly experience this atmospheric pressure, but we can measure it with barometers. The first barometer was

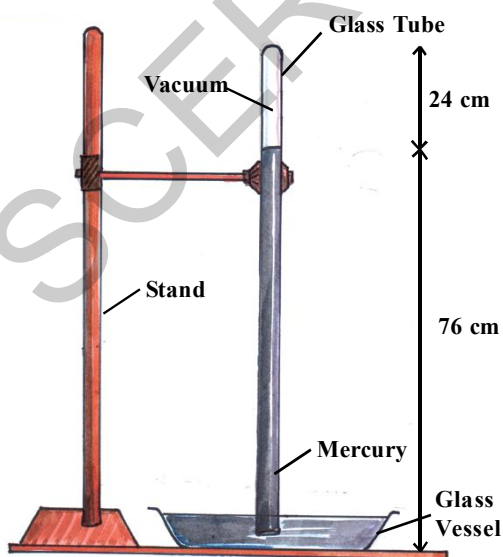

Fig-7: Barometer

invented by 'Torricelli' using mercury. (See fig.- 7)

At normal atmospheric pressure the mercury barometer shows a mercury column of 76 cm height in the glass tube above the surface of the mercury in the bowl. This is known as 1 atmospheric pressure.

- Why is the height of mercury column nearly 76cm in the tube?

What is the state of the mercury column in the tube? It is at rest, so net force on it is zero. The weight of the column in the tube is equal to the force applied on it by the mercury in the bowl due to atmospheric pressure. These two must be equal in magnitude and opposite in direction.

$$\begin{aligned}
 \text{Weight of the mercury column (W)} &= \text{mass of mercury (m)} \times g \\
 &= (\text{Volume}) (\text{density}) g \\
 &= (\text{cross sectional area of the tube A}) (\text{height of the column h}) \rho g \\
 &= Ah\rho g
 \end{aligned}$$

Let ' P_0 ' be the atmospheric pressure.

Force on the column due to the atmospheric pressure = $P_0 A$

then,

$$Ah\rho g = P_0 A$$

$$P_0 = \rho gh \text{ (of mercury)}$$

Since ρ, g are constants, the height of the mercury column depends on atmospheric pressure.

We can now calculate the value of atmospheric pressure ' P_0 ', by substituting the values of height of the mercury column ' h ', density of the mercury ' ρ ' and acceleration due to gravity ' g '.

Height of the mercury column $h = 76\text{cm} = 76 \times 10^{-2} \text{ m}$

Density of the mercury $\rho = 13.6 \text{ gm/cc} = 13.6 \times 10^3 \text{ kg/m}^3$

Acceleration due to gravity $g = 9.8 \text{ m/s}^2$

$$P_0 = h\rho g$$

$$P_0 = (76 \times 10^{-2} \text{ m}) \times (13.6 \times 10^3 \text{ kg/m}^3) \times (9.8 \text{ m/s}^2)$$

$$P_0 = 1.01 \times 10^5 \text{ kg.m/m}^2.\text{s}^2$$

hence, $P_0 = 1.01 \times 10^5 \text{ N/m}^2$ ($\because 1 \text{ kg.m/s}^2 = 1 \text{ newton}$)

This value is also known as one atmospheric pressure. (1 atm)

$1 \text{ atm} = 1.01 \times 10^5 \text{ N/m}^2 = 1.01 \times 10^5 \text{ pascal}$ ($\because 1 \text{ N/m}^2$ is called pascal)



Do you know?

The mass of air that would occupy a cylindrical tube with cross sectional area of 1cm^2 and that extends 30km upto the top of the atmosphere is about 1kg . The weight applied on the surface area of 1cm^2 on the earth is the atmospheric pressure.

Atmospheric pressure

$$P_0 = mg/A = 1 \text{ kg} \times 10 \text{ m/s}^2 / 1 \text{ cm}^2 = 10 \text{ N/cm}^2 \text{ or } 10^5 \text{ N/m}^2 \text{ (} 10^5 \text{ Pascal)}$$

This value is nearly equal to 1 atm.



Think and discuss

- What would happen if the Toricelli experiment is done on moon?
- A stopper is inserted in a small hole of the glass tube of the mercury barometer below the top level of the mercury in it. What happens when you pull out the stopper from the glass tube?
- Why don't we use water instead of mercury in Torricelli experiment? If we are ready to do this experiment, what length of tube is needed?
- Find the weight of the atmosphere around the earth (take the radius of earth as 6400km.)

Pressure at a depth “h” in a liquid

Let us consider a container which contains a liquid of density “ ρ ”.

Consider a cylindrical column of height ‘h’ from the surface of the liquid of cross sectional area “A”. See the fig - 8.

The volume of the liquid column

$$V = Ah$$

Mass = Volume \times density

$$m = Ah \rho$$

$$\text{Weight } W = mg = Ah \rho g$$

You know that from Newton's law, the net force on it is zero, because it is at rest. What are the forces acting on that water column?

There are three forces acting, which are,

- i) Weight (W), vertically down
- ii) Force on top surface due to atmospheric pressure ($P_0 A$), acting vertically down
- iii) Force on the bottom surface of the column due to static pressure of liquid (PA), acting vertically up.

From Newton's laws we get

$$PA = P_0 A + W$$

$$PA = P_0 A + h \rho g A$$

Where P is the pressure at the depth “h” from the surface of the liquid and P_0 is the atmospheric pressure.

$$PA = P_0 A + h \rho g A$$

$$P = P_0 + h \rho g \dots\dots (1)$$

This means that the pressure inside the liquid at a constant depth is constant.

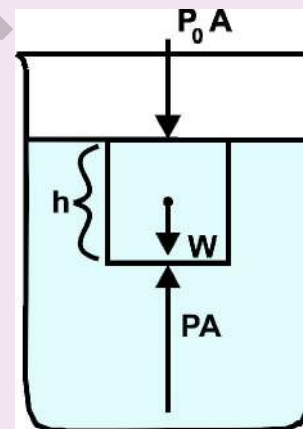

Fig. 8

Pressure difference at different levels of depth in fluids

Let us consider a cylindrical column of liquid of height 'h' with cross sectional area 'A' and let ρ be the density of the liquid. See the fig.- 9.

What is the pressure P_1 in the liquid at depth h_1 ?

From equation (1) we get,

$$P_1 = P_0 + h_1 \rho g \dots\dots (2)$$

Similarly, pressure P_2 at depth h_2 is given by

$$P_2 = P_0 + h_2 \rho g \dots\dots (3)$$

From equations (3) and (2) we get

$$P_2 - P_1 = h_2 \rho g - h_1 \rho g$$

$$P_2 - P_1 = \rho g (h_2 - h_1)$$

from the figure $h = h_2 - h_1$ so

$$\text{we have, } P_2 - P_1 = h \rho g$$

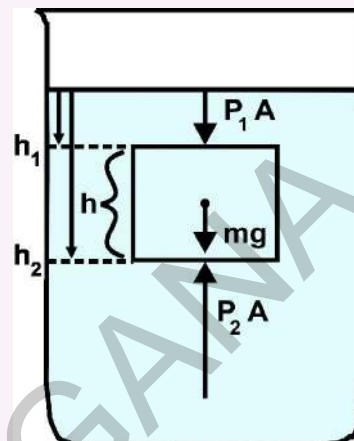

Fig 9

The pressure difference between two levels in that liquid = $h \rho g$.

Here density of the liquid ' ρ ' and ' g ' are constants, so the pressure difference increases with a increase in depth.

• **What happens if we replace this cylindrical liquid column with another object**

which is made up of a material whose density is not equal to the density of liquid?

The pressure difference in the liquid $P_2 - P_1 = h \rho g$ (values of the liquid)

$$P_2 - P_1 = h \times \frac{m}{V} \times g$$

$$P_2 - P_1 = h \times \frac{m}{Ah} \times g$$

$$P_2 - P_1 = \frac{m}{A} \times g$$

$$(P_2 - P_1)A = m \times g \text{ (Weight of the displaced liquid)}$$

Since $F = P \times A$ and $W = mg$

we get $F = W$ (values of the displaced liquid)

Here ' F ' is the force applied on the object and ' W ' is the weight of the displaced liquid. So the force applied on the object by the liquid is equal to the weight of the displaced liquid.

Buoyancy

The force applied on the object in upward direction is called "**Buoyancy**". As per the above equation this buoyant force is equal to the weight of the liquid displaced by the object.

8.7 Measuring the force of buoyancy

We know that when an object is immersed in water it experiences an upward force, the force of buoyancy. Can we measure this upward force? Let's try.

Activity-8

Let us measure the force of buoyancy

Suspend a stone from a spring balance. Note the reading of the spring balance. The reading gives the weight of the stone. Take a beaker half filled with water. Now immerse the stone in the water. Note the reading of the spring balance. The reading of the spring balance gives the 'weight' of the immersed stone. Do you notice any change in the weight of the stone before and after it is immersed in water? You may notice that the stone, when immersed, appears to lose some weight.

- Why does the stone lose weight when it is immersed?

The immersed stone appears to lose weight because the force of buoyancy, exerted on the stone by the water, in the upward direction, serves to 'reduce' the force of gravity. Thus the **apparent loss of weight** must be **equal to the force of buoyancy** acting on the immersed stone. We can measure the force of buoyancy exerted by a liquid, by measuring the apparent loss of weight of an object immersed in that liquid. You will notice that in every case an immersed object appears to lose weight.

When the object floats on the surface of water, it appears as if it has lost all its

weight, that is, the spring balance shows zero reading for floating bodies! For objects that float on a liquid surface, the force of buoyancy balances the force of gravity at the surface of the liquid.

Now let us repeat this activity and measure the weight of the water displaced by the immersed stone.

Activity-9

Measuring the weight of the water displaced by the immersed stone

Suspend a stone from a spring balance. (it is better to take a stone that is more than 300 gm) . Note the reading on the spring balance. The reading gives the weight of the stone. Take an overflow vessel with water and place a graduated beaker below the beak. (Fig.- 10).

Now immerse the stone in the water. Note the reading on the spring balance and

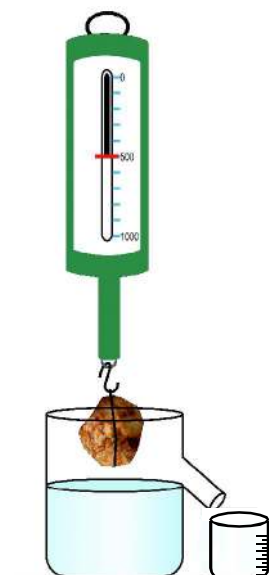

Fig. 10

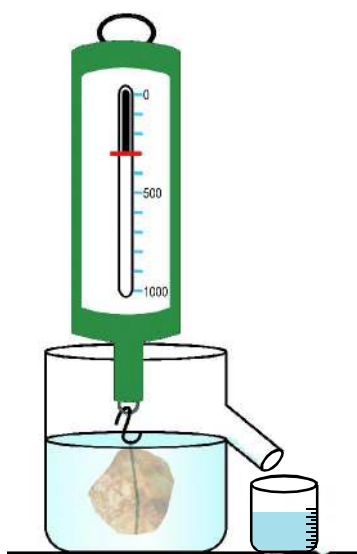

Fig-11

measure the volume of water that overflows into the graduated beaker.

The reading of the spring balance gives the weight of the immersed stone and the beaker reading gives the volume of water displaced by the stone (Figure 11).

- By how much does the weight of the stone appear to be decreased? (Apparent loss of weight of the stone)
- What is the weight of the displaced volume of water?
- Do you observe any connection between the two?

The *apparent loss of weight* of the immersed stone is *equal to the weight of water displaced* by the stone i.e., *equal to the force of buoyancy exerted by the water*.

This wonderful observation was made by Archimedes, an ancient Greek scientist.

Let's look at the story that is associated with this observation.

8.8 Archimedes' principle

Archimedes' principle states that when a body is immersed in a fluid it experiences an upward force of buoyancy equal to the weight of fluid displaced by the immersed portion of the body.



Do you know?



Archimedes (287-212 BC)

Archimedes was a Greek scientist. At that time the King had a crown made of gold. The King however, suspected that the crown made was not of pure gold and asked Archimedes to verify this. Archimedes had to solve the problem without damaging the crown, so he could not melt it down into a regularly shaped body in order to calculate its density. While taking a bath, he noticed that the level of the water in the tub rose as he got in, and realized that this effect could be used to determine the volume of the crown. The submerged crown would displace an amount of water equal to its own volume. By dividing the mass of the crown by the volume of water displaced, the density of the crown could be obtained. This density would be lower than that of gold if cheaper and less dense metals had been added. Archimedes then took to the streets naked, so excited by his discovery that he had forgotten to dress, crying "Eureka!" (meaning "I have found it!").



Do you know?

How did Archimedes solve the King's problem? A simple arrangement could be used to determine whether a golden crown is less dense than gold. The crown and a bar of gold, of the same mass as the crown, are suspended from the two arms of a simple balance as shown in the figure. The balance is lowered into a vessel of water. If the crown (left) is less dense than the gold bar (right), it definitely possesses a larger volume than that of pure gold and will displace more water and thus experience a larger upward buoyant force, causing the balance to tilt towards the gold bar. This would indicate that the crown was not of pure gold!

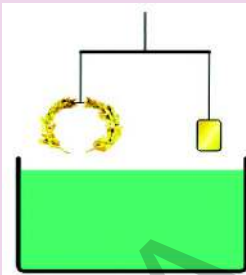

Note: This experiment holds good only when the crown doesn't have any covered hollow portion in it. Think why?



Think and discuss

- Why is it easier for you to float in salt water than in fresh water?
- Why is there no horizontal buoyant force on a submerged body?
- Two solid blocks of identical size are submerged in water. One block is iron and the other is aluminium. Upon which is the buoyant force greater?
- A piece of iron when placed on a block of wood, this makes the wood to float lower in the water. If the iron piece is suspended beneath the wood block, would it float at the same depth? Or lower or higher?

You know that pressure difference at different levels inside the liquid causes buoyancy.

- Can we increase the pressure inside the liquid?

It is only possible when the liquid is enclosed. A scientist named Pascal made a

principle about what happens when an external pressure is applied to an enclosed liquid. Let us know about it.

8.8.1 Pascal's principle

Pascal's principle states that external pressure applied to an enclosed body of fluid is transmitted equally in all directions throughout the fluid volume and the walls of the containing vessel.

Look at Fig.- 12. Here, we have an enclosed volume of fluid in a U-shaped tube. The fluid is enclosed in the tube by two leak-proof pistons in each arm. The area of cross-section of the right and left tubes is A_2 , A_1 ($A_2 > A_1$).

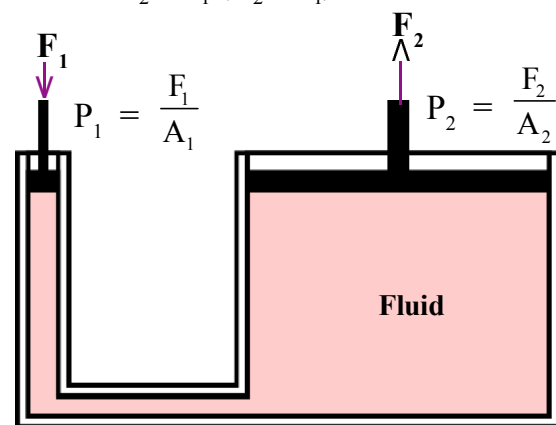

Fig-12: Application of Pascal's principle (bramah press)

When a force F_1 is applied to the left piston the excess pressure acting on the fluid volume is $\frac{F_1}{A_1}$.

According to Pascal's principle, this excess pressure is transmitted equally throughout the fluid volume. That is, every unit area of the fluid 'experiences' this excess pressure of $\frac{F_1}{A_1}$.

The excess pressure in the right-side tube (of cross section area A_2) is also $\frac{F_1}{A_1}$ and since its area is A_2 , the upward force acting on the right piston is $F_2 = \frac{A_2 \times F_1}{A_1}$; which is much larger in magnitude than F_1 .

Thus the application of Pascal's principle results in a large upward force

(thrust) on the right piston when a small downward force is applied on the left piston.

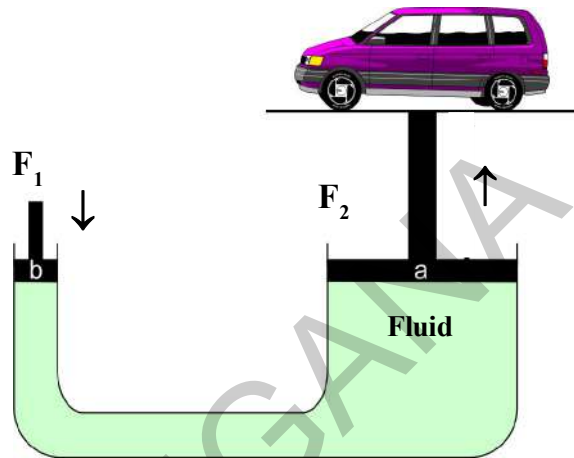

Fig. 13: Hydraulic jack

This principle is used in the design and working of hydraulic jacks/lifts (Fig-13) which you can see in automobile workshops. A small downward force applied by the hand of the operator helps to lift a heavy vehicle with ease!



Key words

Density, Relative density, Lactometer, Hydrometer / densitometer, atmospheric pressure, barometer, buoyancy.



What we have learnt

- Objects having a density less than the liquid in which they are immersed, float on the surface of the liquid.
- All objects experience a force of buoyancy when immersed in a fluid.
- When an object is immersed in a fluid it appears to lose weight (because of buoyancy).
- The apparent loss of weight of an object, which is immersed in a fluid, is equal to the weight of fluid displaced by the object. (Archimedes' principle)

- When an object floats on the surface of a fluid, it displaces a weight of fluid equal to its own weight.
- The pressure exerted by a liquid increases with depth below the surface of liquid.
- External pressure, applied to an enclosed volume of fluid, is transmitted equally in all directions throughout the fluid volume. (Pascal's principle)



Improve your learning



I. Reflections on concepts

1. Why do some objects float on the water? And some sink? (AS₁)
2. Explain density and relative density and write their formulae. (AS₁)
3. Explain buoyancy in your own words. (AS₁)
4. How can you find the relative density of a liquid? (AS₃)
5. Draw the diagram of a mercury barometer. (AS₅)

II. Application of concepts

1. A solid sphere has a radius of 2 cm and a mass of 0.05 kg. What is the relative density of the sphere? (AS₁) [Ans: 1.49]
2. A small bottle weighs 20 g when empty and 22 g when filled with water. When it is filled with oil it weighs 21.76 g. What is the density of oil? (AS₁) [Ans: 0.88 g/cm³]
3. An ice cube floats on the surface of water filled in glass tumbler (density of ice = 0.9 g/cm³). Will the water level in the glass rise? When the ice melts completely (AS₁)
4. Find the pressure at a depth of 10m in water if the atmospheric pressure is 100kPa. [1Pa=1N/m²] [100kPa = 10⁵ Pa = 10⁵ N/m² = 1 atm.] (AS₁) [Ans: 198 kPa]

III. Higher Order Thinking Questions

1. Can you make iron to float in water? How? (AS₃)
2. Where do you observe Archimedes principle in daily life? Give two examples. (AS₇)
3. Do all objects that sink in water, sink in oil? Give reason. (AS₁)



Multiple choice questions

1. Unit of relative density is []
a) g/cm^3 b) cm/g^3 c) N/m^2 d) No units
2. The instrument used to measure the purity of milk is []
a) Barometer b) Hygrometer c) Lactometer d) Speedometer
3. If P_0 = Pressure, ρ = Density, h = height, and g = acceleration due to gravity then the atmospheric pressure = []
a) $P_0 = \rho hg$ b) $P_0 = mgh$ c) $P_0 = vgh$ d) $P_0 = \frac{1}{2} mgh$
4. The first barometer with mercury was invented by []
a) Pascal b) Archimedis c) Newton d) Torecelli
5. The hydraulic jack which is used in automobile work shops, works on the principle of []
a) Archimedes b) Pascal c) Torecelli d) Newton
6. The density of water at 25°C is []
a) 1g/cm^3 b) 2g/cm^3 c) 3g/cm^3 d) 0.99g/cm^3



Suggested Experiments

1. Conduct an experiment to find the relative densities of different substances and write a report.
2. Conduct an experiment to understand the phenomenon that a stone immersed in water loses its weight. Write a report on it.



Suggested Projects

1. The oil brakes in vehicles works on the Pascal's principle. Collect the information on working of air brakes in vehicles and write a report.
2. Find the relative densities of different fruits and vegetables and write a report.



In previous chapters we have learnt that all matter is made up of atoms. According to Dalton, atoms were indivisible. That means that they could not be divided into still smaller parts. Atoms of an element are all identical to each other and different from the atoms of other elements.

Atoms are too small to be seen with naked eye. Scientists relied on indirect evidence to prove the existence of atoms. Since they could not see the atom, they could find its properties on the basis of experiments. Very soon they realized that atoms could gain or lose charges. During electrolysis experiments, Michael Faraday discovered the presence of charged particles.

Michael Faraday's discovery raised few questions about the indivisibility of atoms.

How could a neutral atom become electrically charged? It is a contradiction to Dalton's theory that the atom was indivisible. This led to an idea that there must exist some tiny particles in atom which are responsible for atom to behave sometimes as a charged particle. As atom is considered electrically neutral, it probably had some positive constituents and equal number of negative constituents to maintain its electrical neutrality. This gave scope to think about sub-atomic particles.

9.1 Sub-atomic Particles

In science, theories change when scientists discover new facts or clues. Sometimes, an idea or model must be changed as new information is gathered. Dalton proposed that atoms could not be divided. Experimental evidence began to show that atoms were divisible

and are made up of small particle(s). Since these particles are smaller than the atom and are present inside an atom, they are called sub-atomic particles.

Since atoms are neutral they should have at least two types of sub-atomic particles, one is positively charged and another is negatively charged. In fact, three different subatomic particles were discovered. Let us see how ideas about atoms have changed over the time with the discovery of sub-atomic particles.

9.2 Electron, Proton and Neutron

You read about Faraday's electrolysis experiments earlier. Other experiments on gases were carried out in the latter part of 19th century. Scientists studied the effects of applying electric current to gases at low pressure by using discharge tubes. Other scientists did similar experiments in vacuum tubes. In 1897, a British physicist Joseph John Thomson demonstrated on the basis of these experiments that negatively charged particles are present in the atoms.

Initially, Thomson thought that the negative particles would be different for each element. But after carrying out experiments with many different materials, he found that the negatively charged particles from all the materials were always identical. He concluded that same type of negatively charged particles were present in the atoms of all the elements.

These particles had a very small mass and are now called **electrons**.

Electrons were the first sub-atomic particles discovered and studied. An electron is represented as 'e⁻'. The mass of an electron is considered to be negligible and its charge is considered as to be one unit negative.



Think and Discuss

An atom is electrically neutral. But the electrons present in it are negatively charged particles. If only negative charges were present, the atom would not be neutral. Then, why are atoms considered to be neutral ?

The atom must also contain some positively charged particles so that the overall charge on it becomes neutral. This sub-atomic particle would have a charge that balances the charge of the electrons. This sub-atomic particle was named as **proton** in 1920. Its mass was approximately 1836 times greater than that of the electron. It is represented as 'p⁺' and its charge is taken as one unit positive.

In 1932, James Chadwick discovered another sub-atomic particle which had no charge and had a mass nearly equal to that of a proton. It was eventually named as **neutron**. In general, a neutron is represented as 'n⁰'.

From this discussion we can conclude that atoms are made of small particles called protons, neutrons, and electrons. Each of these particles is described in terms of measurable properties, like mass and charge. The proton and electron have equal, but opposite, electrical charges. A neutron has no electrical charge. The mass of the electron is about $\frac{1}{1836}$ th that of a proton.

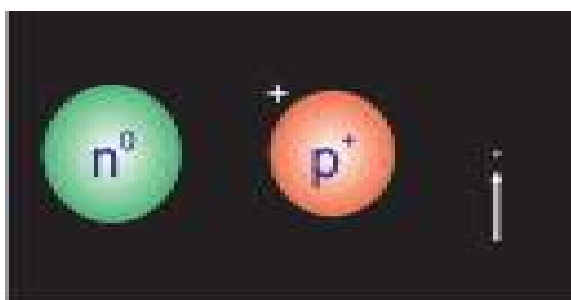

Fig-1: neutron, proton and electron

- If an atom consists of sub-atomic particles like protons, neutrons and electrons, how are they arranged in the atom?

9.3 Structure of an Atom

Activity-1

Sketch the structure of atom as you imagine.

You learnt about electron, proton and neutron. Suppose you want to arrange them in an atom, how do you do it?

Many arrangements are possible. Think that atom looks like a room. You can arrange the particles in alternating rows. Can you draw and show how it will look? Imagine and draw another arrangement of sub-atomic

particles inside a spherical shape keeping in view the nature of sub-atomic particles.

- In how many ways can you arrange these sub-atomic particles in a spherical shape?

Discuss with your friends and try to prepare a model to show various ways of arranging the sub-atomic particles in the atom.

To understand the structure of an atom, scientists developed different atomic models.

9.3.1 Thomson's Model of the Atom

This atomic model was proposed by J.J. Thomson in 1898. This model was commonly called the **plum pudding model**, referring to the way the fruit pieces are distributed throughout a plum pudding.



Fig-2(a)



Fig-2(b)

According to this model:

1. An atom is considered to be a sphere of uniform positive charge and electrons are embedded in it, as shown in figure 2(a).
2. The mass of the atom is considered to be uniformly distributed throughout the atom.

3. The negative and the positive charges are supposed to balance out and the atom as a whole is electrically neutral.

A more familiar example that represents Thomson's atomic model is watermelon (figure-2(b)). The positive charge is spread throughout the atom like the red part of watermelon. The black seeds distributed through out the red part represents electrons. Thomson's model was modified by one of his students. What is the reason for its modification? The reason was that some of the experiments carried out by Rutherford, a student of Thomson, gave results, which were not in favour of Thomson's model.



Do you know?

Besides winning the Nobel Prize in Physics himself, seven of Thomson's research students and even his own son, George, won Nobel Prizes in Physics. One of Thomson's students was Ernest Rutherford.

9.3.2 Rutherford's α particles scattering experiment

Ernest Rutherford was a scientist born in New Zealand. In 1909, he did some experiments using gold foil and alpha (α) particles. Alpha (α) particles consist of two protons and two neutrons bound together. Since they do not have any electrons, they are positively charged with two units of

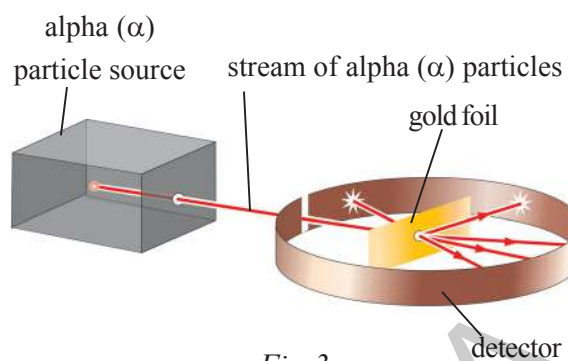

Fig-3

charge. Let us see the experimental set up and understand Rutherford's experiment.

There is a source of the fast moving alpha particles which have a considerable amount of energy. The stream of alpha (α) particles is directed towards a very thin gold foil.

The gold foil was placed inside a detector in such a way that the detector would show a flash of light when an alpha (α) particle strikes it (see fig-3). The entire arrangement was kept in a vacuum chamber.

Think of Thomson's model of the atom. When the alpha particle hit the foil, Rutherford expected that they all would be deflected by the positive charge spread evenly throughout the gold atoms.

Rutherford's Observations

But, it was found that most of the alpha particles passed straight through the atoms without any deflection, some particles deflected in small angles. Only very few

particles were deflected through large angles and a very very small number of particles were reflected right back as shown in figure 4.

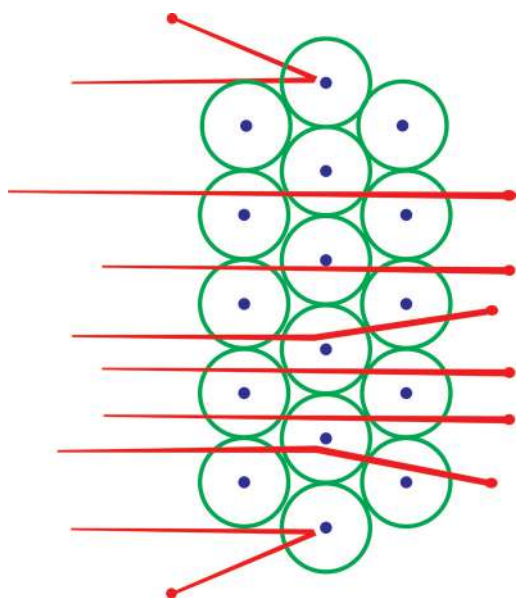

Fig-4: Scattering of alpha particles



Do you know?

On average, for every 20000 alpha particles that were fired at the gold foil during Rutherford's famous experiment, only one was reflected back.

Let us try to understand the results of Rutherford's experiments.

Suppose you throw a small stone at a solid wall in a horizontal direction. It will not go through. But if you throw stones through a fence of considerably big gaps, lots of them would pass through the gaps.

Thomson's model was assumed that the positive charge was uniformly distributed

throughout the atom and it was expected that all the alpha particles would be deflected. Since the alpha particles are very big, the deflection was expected through small angles. But Rutherford found that most of the particles passed through the gold foil like stones thrown to a fence of big gaps as mentioned in the above example. This led Rutherford to think about new atomic model.

Rutherford concluded from the alpha particles scattering experiment that :

- (i) Most of the space inside the atom is empty because most of the alpha particles passed through the gold foil as shown in figure 4.
- (ii) A very small fraction of alpha-particles that were deflected right back indicated that they had met a very large positive charge and mass which repelled the charge on the alpha particle. So, all the positive charge must be concentrated in a very small space within the atom.

On the basis of his experiment, Rutherford put forward the **nuclear model of an atom**, which had the following features:

- i) As shown in Fig-4 all the positively charged particles in an atom formed a small dense centre, called the **nucleus** of the atom. The electrons were not a part of nucleus.

- ii) He also proposed that the negatively charged electrons revolve around the nucleus in well-defined orbits. Rutherford's model is sometimes referred to as the planetary model because the motion of the electrons around the nucleus resembles the motion of the planets around the Sun.
- iii) The size of the nucleus is very small as compared to the size of the atom.

Try to sketch Rutherford's model of the atom.



Think and discuss

Compare Rutherford and Thomson's models of the atom on the following basis:

- Where is the positive charge placed?
- How are the electrons placed?
- Are they stationary inside the atom or moving?

9.3.3 Limitations of Rutherford's atomic model

- Did you observe any defect with Rutherford's model of the atom?

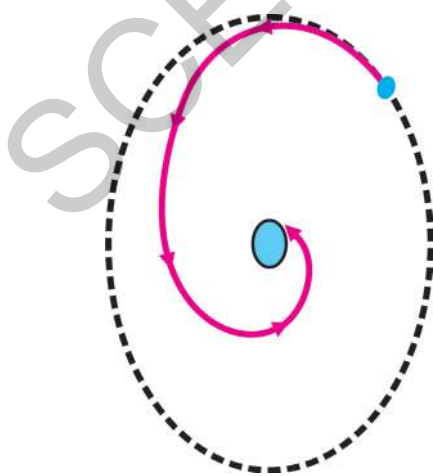

Fig-5

Think of an atom like hydrogen with one electron and one proton. The electron is attracted by the proton in the nucleus. Even in circular motion around the nucleus, the electron should have an acceleration.

An accelerated charged particle moving in a circular path would always radiate energy continuously. Thus, the revolving electron would lose energy continuously and get directed towards the positively charged nucleus as shown in fig-5 and eventually crash into the nucleus.

If this is true, the atoms would become highly unstable and the matter would not exist in the form that we see it now. But we know that atoms are stable.

So we need to ask: Why is atom stable?

- Can you suggest any other arrangement of sub-atomic particles in the atom which prevents the revolving electron to fall into the nucleus?

In 1913, a Danish scientist Neils Bohr suggested an atomic model to explain structure of atom and to overcome Rutherford's limitations.

Bohr's Model of the Atom

In order to overcome the limitations of Rutherford's model, in 1913, Niels Bohr put forward a thought that electrons can be found only in certain *energy levels*, or regions, around the nucleus.

Electrons must gain energy to move to a higher energy level or they must lose energy to move to a lower level.

Think of books arranged in a bookshelf. They can be placed on a higher shelf or lower shelf but never between shelves.

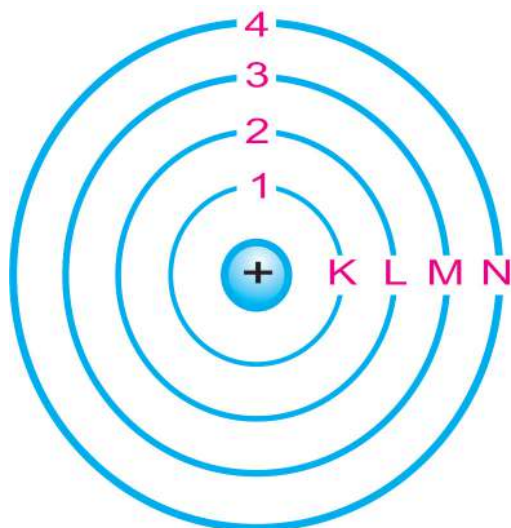

Fig-6: Energy levels of an atom

Restricting the path of electron inside the atom, Neils Bohr made the following postulates about the model of an atom:

1. The electrons revolve round the nucleus in discrete fixed circular orbits of the atom. These orbits or shells are called stationary energy levels.
2. While revolving in these discrete orbits the electrons do not radiate energy and this is the reason why electrons do not fall into the nucleus.
3. The electron orbits or shells are represented by the letters K, L, M, N... or the numbers, $n=1, 2, 3, 4, \dots$ as shown in the figure 6.

- Do you think that Bohr's model is the final model of the atom?

Niels Bohr could successfully explain the properties of a hydrogen atom through the atomic spectra emitted by hydrogen atom employing this model but this model could not predict the spectra of atoms or ions with more than one electron.

You must have noticed that none of the atomic models that have been studied so far, have mentioned about neutrons. This is because neutron was discovered later in 1932. Until Rutherford's and Bohr's time the neutron had not been discovered. Neutron was discovered nearly two decades later. Except hydrogen atom, the atoms of all other elements contain neutrons in their nuclei.

We studied that the mass of neutrons and proton is almost equal and is about 1836 times heavier than the mass of the electron. So the mass of the entire atom is due to protons and neutrons. Later, it was discovered that most of the mass was concentrated inside the nucleus and therefore the neutrons are also present inside the nucleus.

The model of the atom, as we know it today, is the contribution of many scientists. Let us observe the history of the Atom in the given chart.

History of Atom

Matter is composed with Indivisible particles

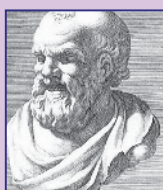

Democritus

442 B.C.

1803 A.D.

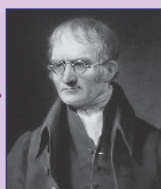

John Dalton

First Atomic Theory

Discovery of Canal Rays

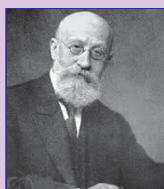

Goldstein

1886 A.D.

1898 A.D.

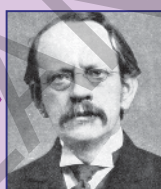

J.J. Thomson

Discovery of electron in cathode rays experiment

Discovery of Nucleus

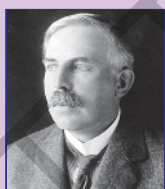

Ernest Rutherford

1909 A.D.

1913 A.D.



Neils Bohr

Electrons in Stationary orbits – Introduction of energy levels

Atomic Number

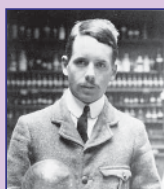

Henry Mosley

1913 A.D.

1931 A.D.



James Chadwick

Discovery of Neutron

9.4 Distribution of electrons in different orbits (Shells)

According to atomic models, electrons move around the nucleus of atom in various shells. Electrons in different shells have different energies. Each shell is represented by a number 'n' which is known as a shell number or energy level index. The shell closest to the nucleus (and has the lowest energy) is called the K-shell ($n = 1$), the shell farther away (and has higher energy than K-shell) is called the L-shell ($n = 2$), etc. Similarly other shells are denoted as (M, N,)

- How many electrons can be accommodated in each shell of an atom?
- Can a particular shell has just one electron?
- What is the criteria to decide number of electrons in a shell?

After explaining the structure of atom with different atomic models, scientists started describing the distribution of electrons in different energy levels or shells of an atom.

Bohr and Bury proposed the following rules for electron distribution.

Rule 1: The maximum number of electrons present in a shell is given by the formula $2n^2$, where 'n' is the shell number or energy level index, which takes values 1, 2, 3.... The maximum number of electrons that can be accommodated in each shell is shown in the table 1.

Table - 1

Shell number (n)	The maximum number of electrons in a shell ($2n^2$)
K-shell (1)	$2(1)^2 = 2$
L-shell (2)	$2(2)^2 = 8$
M-shell (3)	$2(3)^2 = 18$
N-shell (4)	$2(4)^2 = 32$

Rule 2: Each energy level or electron shell is further divided into sub shells. The maximum number of electrons that can be accommodated in each sub shell is 2.

Rule 3: Electrons cannot be filled in a given shell unless the inner shells are completely filled i.e., shells are filled in stepwise manner.

Let us take the example of oxygen where $Z=8$. Since number of electrons is equal to number of protons, it has eight electrons.

Step1: The K shell can accommodate maximum 2 electrons. So the first 2 electrons fill the shell of $n = 1$.

Step 2 : The other 6 electrons will fill the higher shell $n = 2$ or the L shell.

Step 3: Then, the electronic structure for oxygen atom is 2, 6.

Arrangement of electrons for the first eighteen elements is shown schematically in figure 7.

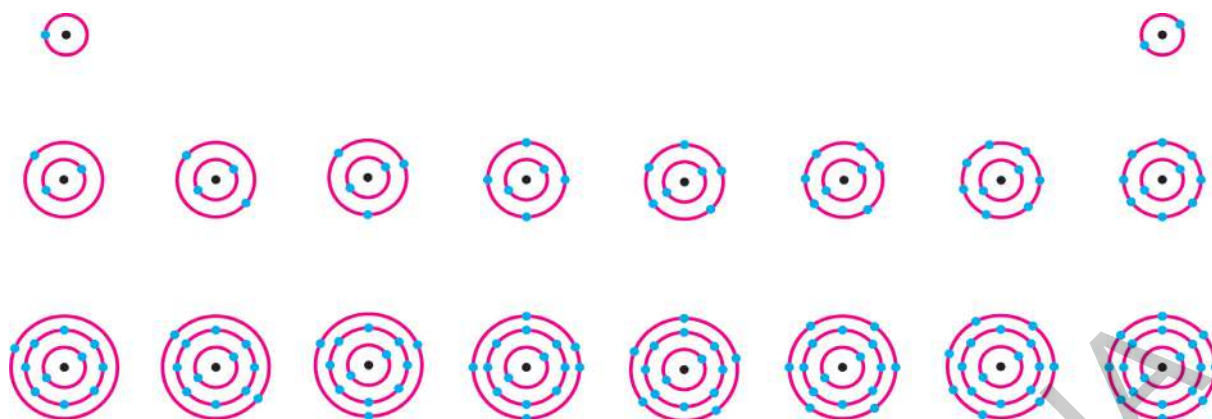

Fig-7: Arrangement of electrons for the first eighteen elements

9.4.1 Valency

We have learnt arrangement of the electrons in an atom in different shells/orbits.

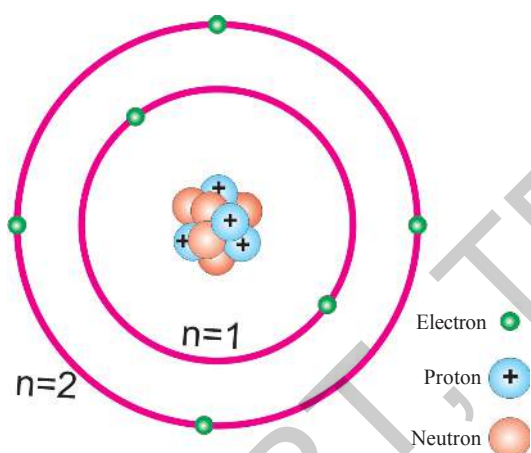

Fig-8

Let us consider a carbon atom. The atomic number of carbon atom is 6. Hence it possesses 6 electrons, which surround its nucleus, as shown in the figure 8.

According to Bohr-Bury rule, there should be two electrons in the innermost shell ($n=1$). Out of 6 electrons of carbon two electrons occupy first shell ($n=1$). The remaining four electrons occupy the outer most shell $n=2$. The electrons

present in the outermost shell of an atom are known as the valence electrons. Therefore, the number of electrons present in outermost orbit of an atom is called its valency.

Valency of an atom explains the combining capacity of an element with other elements in the above example the valency of carbon atom is 4.

Let us consider some more examples, if you consider the atoms like hydrogen/lithium/sodium, it contains one electron in its outermost shell. Therefore valency of hydrogen, lithium or sodium is one. Can you tell, valencies of magnesium and aluminium? They are two and three, respectively, because magnesium has two electrons in its outermost shell and aluminium has three electrons in its outermost shell.

If the number of electrons in the outer shell of an atom is nearly close to its full capacity, then valency is determined in a different way.

For example, the fluorine atom contains 7 electrons in outermost shell, and its valency could be 7. But it is easier for fluorine to gain one electron than to lose seven electrons for obtaining 8 electrons in its outermost shell. Hence, its valency is determined by subtracting seven electrons from eight and which gives a valency of '1', for fluorine. In a similar manner we can calculate the valency of oxygen.

- What is the valency of oxygen that you can calculate by the method discussed above?

Observe the following Table. Valency of the first eighteen elements is given in the last column of Table 2.



Think and discuss

- Phosphorus and sulphur show multiple valency. See table 2. Why some elements show multiple Valency? Discuss with your friends and teachers.

Table 2

Name of element	Symbol	Atomic number	Number of Protons	Number of Neutrons	Number of Electrons	Distribution of electrons				Valency
						K	L	M	N	
Hydrogen	H	1	1	-	1	1	-	-	-	1
Helium	He	2	2	2	2	2	-	-	-	0
Lithium	Li	3	3	4	3	2	1	-	-	1
Berilium	Be	4	4	5	4	2	2	-	-	2
Boran	B	5	5	6	5	2	3	-	-	3
Carbon	C	6	6	6	6	2	4	-	-	4
Nitrogen	N	7	7	7	7	2	5	-	-	3
Oxygen	O	8	8	8	8	2	6	-	-	2
Fluorine	F	9	9	10	9	2	7	-	-	1
Neon	Ne	10	10	10	10	2	8	-	-	0
Sodium	Na	11	11	12	11	2	8	1	-	1
Magnesium	Mg	12	12	12	12	2	8	2	-	2
Aluminium	Al	13	13	14	13	2	8	3	-	3
Silicon	Si	14	14	14	14	2	8	4	-	4
Phosphorus*	P	15	15	16	15	2	8	5	-	5,3
Sulphur*	S	16	16	16	16	2	8	6	-	2,6
Chlorine	Cl	17	17	18	17	2	8	7	-	1
Argon	Ar	18	18	22	18	2	8	8	-	0

9.5 What is the importance of valency?

See electron distribution in helium in figure 7 and table '2'. You will notice that the shell of helium has two electrons in outer most shell and the shell is filled to its full capacity. Neon and Argon have 8 electrons in their outer most shells. These three gases are very stable and have low reactivity. Scientists, studying the distribution of electrons in different shells concluded that the special arrangements of electrons in He, Ne and Ar make them stable or un reactive with other elements. They do not react with other elements to form compounds. In other words we can say that these gases are chemically inactive and also known as inert or noble gases.

	K	L	M	N
He	2			
Ne	2	8		
Ar	2	8	8	

Atoms of all the noble gases except those of helium have 8 electrons' in their outer most shell. Thus an atom with eight electrons or an octet in their outer most shell, is chemically stable, or does not combine with other atoms. An atom with two electrons in its outer most shell, also is more stable when there is only one shell present in it.

An outermost-shell which has eight electrons is said to possess an octet. Atoms of an element thus react with other atoms, so as to achieve an octet in their outermost

shell. From the above discussion, we can conclude that when an element reacts to form compounds their atoms must combine in such way that they can attain the stable electron distribution of noble gases.

An atom can achieve an octet by two ways. 1) by transfer of electrons 2) by sharing of electrons. Both the processes result in the formation of bonds between atoms.

Let us go back to the question of why do atoms of different elements are different? How can you distinguish between the atoms of one element from the atoms of other element? An element can be recognised by certain characteristics of its atoms.

9.5.1 Atomic number

We know that, the nucleus is at the centre of the atom and contains the protons and neutrons. Elements differ from one another according to the number of protons in their atomic 'nuclei'. This value is called the element's atomic number and is denoted by the letter Z.

Atomic number is the number of protons in the nucleus of an atom

9.5.2 Atomic mass number

- Can we consider the number of neutrons as a characteristic of an atom?

The mass of an atom which is a characteristic of an atom depends on the number of neutrons and protons its nucleus contains. Number of protons in a nucleus is denoted by Z (atomic number) and number of neutrons of a nucleus is denoted by N .

The number of nucleons, is the total number of protons and neutrons in an atom. It is called the atomic mass number and is denoted by the letter A .

Atomic mass number = atomic number + neutron number

$$A = Z + N$$

- *Mass number is a nearest numerical to the mass of an individual atom.*
- *Mass number is the number of protons plus the number of neutrons.*

9.6 Writing symbols of atoms

In standard notation to represent an atom, the atomic number, mass number and symbol of the element are written as:

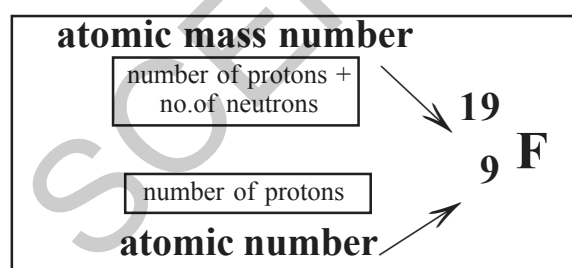

Read as F - 9-19

F is the symbol of the element fluorine, its atomic number is written at bottom left. It tells us that this atom has 9 protons. The mass number is written at top left. It tells

us that the fluorine has 19 nucleons (protons + neutrons).

Therefore the number of neutrons present in fluorine is equal to $19 - 9 = 10$ neutrons. ($N = A - Z$).

9.7 Isotopes

It must be clear to you that every element has a unique atomic number, or number of protons.

What about mass number? Does every element has a unique mass number, which is different from the mass number of other elements?

No, the mass number of an element is not unique because there are more than one type of atoms of the same element present in nature in certain cases. Observe the following figure of different Hydrogen atoms. What do you understand?

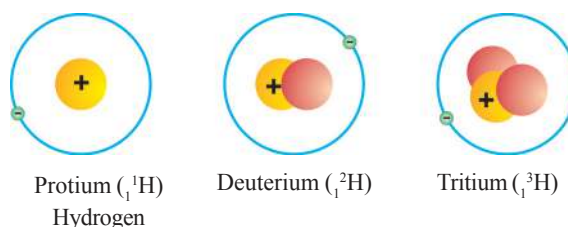

Fig-9

An atom of hydrogen has one nucleon in its nucleus, an atom of deuterium has two nucleons in its nucleus, and tritium has three. Since atoms of hydrogen, deuterium and tritium have only one proton in their nuclei, they only have one electron. But number of neutrons present in hydrogen atom is not same in all cases.

The atoms of the same element which have the same number of protons but have different number of neutrons are called **isotopes**. Deuterium and tritium are isotopes of hydrogen. The chemical properties of isotopes are similar. But their physical properties are different.

For Example: Carbon has three stable isotopes. Isotopes can also be represented by their element name followed by the mass number. See following notations.

Carbon-12, Carbon-13 & Carbon-14



Do you know?

Two elements share the record for the highest number of known isotopes. Both xenon and cesium have 36 isotopes.

How do we determine the atomic mass of an element with isotopes?

In nature, most elements occur as a mixture of two or more isotopes, each isotope has a certain percentage of natural occurrence.

For example, consider the isotopes of Chlorine. It occurs in nature in two

isotopic forms, with masses 35 units and 37 units. The isotope with mass 35 is present in 75% and isotope with mass 37 is present in 25% in nature

The atomic mass of an element is taken as an average mass of all the naturally occurring atoms of the sample element.

The average atomic mass of chlorine atom, on the basis of above data, will be

$$\begin{aligned} & \left(35 \times \frac{75}{100} + 37 \times \frac{25}{100} \right) \\ & = \left(\frac{105}{4} + \frac{37}{4} \right) = \frac{142}{4} = 35.5\text{u} \end{aligned}$$

9.7.1 Applications of isotopes

Some isotopes are used for solving chemical and medical mysteries. Isotopes are also commonly used in the laboratory to investigate the steps of a chemical reaction.

- The isotope of uranium is used as a fuel in nuclear reactors.
- The isotope of iodine is used in the treatment of goitre (thyroid).
- The isotope of cobalt is used in the treatment of cancer.



Key words

Atom, sub-atomic particle, electron, proton, neutron, nucleus, atomic number (Z), Atomic mass number (A), valency, isotopes



What we have learnt

- An atom is the smallest particle of an element that retains the identity of the element.
- John Dalton's atomic theory described elements in terms of atoms, which he believed to be small, indivisible particles that make up all matter. He stated that all the atoms of the same element are identical in mass and size, but atoms of different elements are different.
- The three sub-atomic particles of an atom are: (i) electron, (ii) proton (iii) neutron.
- Electron is a negatively charged particle of the atom.
- Proton, a positively charged particle is the part of atomic nucleus.
- Neutron, an uncharged particle is the part of atomic nucleus.
- Credit for the discovery of electron and neutron goes to J.J. Thomson and J. Chadwick respectively.
- Thomson determined that atoms contain negatively charged particles, which are now called electrons. He developed a model of the atom that shows electrons embedded throughout the mass of positively charged material.
- Rutherford's alpha-particle scattering experiment led to the discovery of the atomic nucleus.
- Ernest Rutherford's model says that the atom has large empty space, with a small, dense, positively charged nucleus in the centre.
- Neils Bohr modified Rutherford's model of the atom by stating that electrons move in specific energy levels around the nucleus.
- The atomic number of an element is the same as the number of protons in the nucleus of its atom.
- The mass number of an atom is equal to the number of nucleons (protons, Neutrons) in its nucleus.
- Valency is the combining capacity of an atom.

- An atom with eight electrons or an octet in their outer most shell is chemically stable, or does not combine with other atoms.
- Isotopes are atoms which have the same number of protons, but a different number of neutrons



Improve your learning



I. Reflections on concepts

1. What are the three subatomic particles? (AS₁)
2. What were the three major observations Rutherford made in the gold foil experiment? (AS₁)
3. Give the main postulates of Bohr's model of an atom. (AS₁)
4. State the valencies of magnesium and sodium (AS₁)

II. Application of concepts

1. Compare the sub-atomic particles electron, proton and neutron. (AS₁)
2. What are the limitations of J.J. Thomson's model of the atom? (AS₁)
3. Define valency by taking examples of nitrogen and boron. (AS₁)
4. What is the main difference among the isotopes of the same element? (AS₁)
5. Fill in the missing information in the following table. (AS₁)

Name	Symbol	Atomic Number (Z)	Mass Number (A)	Number of Neutrons	Number of Electrons
Oxygen	$^{16}_8\text{O}$	8	16	8	8
		7	7		
	$^{34}_{16}\text{S}$				
Beryllium			9		
		12	24		
		12	25		

III. Higher Order Thinking Questions

1. Cl- has completely filled K, L & M shells. Explain it based on Bhor-Bury theory. (AS₁)
2. Explain the efforts made by scientists to explain the structure of atom by developing various atomic models? (AS₆)



Multiple choice questions

1. Electron was invented by []
a) Thomson b) Chadwick c) Goldstein d) Stoney
2. Proton was invented by []
a) Thomson b) Chadwick c) Goldstein d) Stoney
3. Neutron was invented by []
a) Thomson b) Chadwick c) Goldstein d) Stoney
4. α - particles are made up of the following primary particles []
a) 2 protons and 2 neutrons b) 2 Protons and 2 Electrons
c) 2 Neutrons and 2 Positrons d) 2 Protons and 2 Neutrinos
5. Which model of atom is known as Planetary model []
a) Thomson's model b) Rutherford's model
c) Bohr's model d) Modern atomic model
6. Valency of Aluminium is []
a) 1 b) 2 c) 3 d) 4
7. The gas which is stable without octet configuration is []
a) Neon b) Argon c) Radon d) Helium
8. The sum of the number of protons and neutrons in an atom is known as its []
a) Mass number b) Atomic number c) Valency d) Ion number
9. Deuterium and Tritium are the Isotopes of— []
a) Nitrogen b) Oxygen c) Hydrogen d) Helium
10. The electronic configuration of Sodium is []
a) 2,8 b) 8,2,1 c) 2,1,8 d) 2,8,1



Suggested Projects

1. Write a report on the history of unveiling the structure of atom from John Dalton to Neils Bohr.



In previous few chapters you have learnt about various ways of describing the motion of objects and causes of motion. In performing our day - to - day activities we use various words like work, energy, and power which are closely related to each other. Sometimes we use these words without paying much attention. In this chapter you will examine these concepts more carefully.

People carry out various tasks in daily life. For example, lifting of weights, carrying of weights, sweeping / cleaning of house, cooking of food and watering of plants in the garden etc are some of the day-to-day activities.

Similarly you might have also observed that people employ machines in their houses to carry out different tasks like blowing of air by fan, pumping of water by electric motor, heating of water by electric heater, etc.

Washing machines and vacuum cleaners are used for cleaning of clothes and cleaning the house respectively.

- How are these works being done?

- What do you need to do these works?

Both human beings and machines need energy to do work. Generally this energy is derived by human beings from food they eat and for machines through the fuel or electricity supplied to them.

In all the examples mentioned above, we notice that a person or a machine doing work spends some energy to do work. For example to lift your school bag you spend some energy. Similarly an electric fan uses some electric energy for blowing air.

- Where does the energy spent go ultimately?
- Is there any transfer of energy while work is being done?
- Can we do any work without transfer of energy?

Think about various works you observed and try to identify the force employed for doing the work and the object on which the work was done. Discuss with your friends about possibility of energy transfer during work.

Work

In our daily life, we use the term 'work' in various situations. The word 'work' takes on different meanings depending on the situation. For example the statements like 'I am working in a factory', 'The Ramayana is a great work of Valmiki' 'The machine is in working condition' 'There are large number of worked out problems in this book' 'Let us work out a plan for next year' etc have different meanings. There is a difference between the way we use the term 'work' in our day-to-day life and the way we use it in Science.

Let us examine these situations.

- i) Priyanka is preparing for examinations. She spends lot of time in studies. She reads books, draws diagrams, organizes her thoughts, collects question papers, attends special classes, discusses problems with her friends and performs experiments, etc.

In our common view 'she is working hard'. But if we go by scientific definition of work, the above mentioned activities are not considered as work.

- ii) Rangaiah is working hard to push the huge rock. Let us say the rock does not move despite all efforts by him. He gets completely exhausted and tired. According to our common view he worked hard but as per science he has not done any work on the rock.

- iii) Let us assume you climb up the staircase and reach the second floor of a building. You spend some energy to do this. In our common understanding you are not doing any work but as per science you have done a lot of work to reach the second floor of the building.

In our daily life we consider any useful physical or mental labour as 'work'

For example we consider cooking of food, washing of clothes, sweeping, doing home work, reading, writing etc. as works. But according to scientific definition of work all of these activities are not considered as work, only a few of them are considered as work.

- What is work?
- Why is there difference between general view of work and scientific view of work?

10.1 Scientific meaning of the work

To understand the way we view work and scientific meaning of work let us observe the following examples.

Situation - 1



Fig - 1

A man lifts cement bags from the ground and keeps them one by one in a lorry.

Situation - 2



Fig - 2

A girl is pulling a toy car on the ground and the trolley moves a distance.

Situation - 3

A boy is trying to push a huge rock lying in a play ground.



Fig - 3

Situation - 4

A porter is waiting on the platform of a railway station with luggage on his head.



Fig - 4

- Are all the people mentioned in the above examples doing work?
- How do you define work?

To know the meaning of work according to science analyse the above examples as per the table in the following activity 1.

Activity-1

Let us understand the meaning of work as per science

Copy the table-1 given in the next page in your note book.

Discuss with your friends whether work is being done in each of the examples mentioned above. What could be your reason to say that work has been done? Write your reasons in the table-1.

After careful comparison of all the above mentioned examples, you can understand that in each case the person involved in action/ doing work, spends some energy to perform the actions. In some cases there is a change in the position of the object on which work has been done, For instance in situation-1 the position of the bag is changed from ground to the height of the lorry, and similarly in situation-2 the toy car moved through a distance by changing its position.

In some other cases though the person is doing the work and spends energy, there is no change in the position of the object on which work has been done. Like in situation-3, the boy who is trying to push the huge rock by applying force on it spends lot of energy though there is no change in the position of the rock. Similarly in situation-4,

Table - 1

Situation	Whether work has been done or not ? (Yes/No)	Who is doing the work? (Name the force)	Object on which work has been done?	Reason to say that work has been done	The changes you notice in objects on which work has been done.
1	Yes	Man, Muscular force	Cement bag	The person is lifting the bag from ground to lorry using muscular force	The cement bag moved from the ground to the height of the lorry
2					
3					
4					

the porter standing on the railway platform with luggage on his head spends a lot of energy against the gravitational force acting on the luggage though there is no change in the position of luggage.

In our common perception of work all the forces acting on bodies applied by persons mentioned in situations 1 to 4 are doing work but according to science only the forces applied by persons mentioned in situations 1 and 2 are doing the work.

According to the scientific concept of the work, two conditions need to be satisfied in order to say that work has been done.

1. A force should act on the object.
2. The object must be displaced or there must be change in the position of the object.

Let us define the work.

10.2 Definition of work in science

Let us consider the following example:

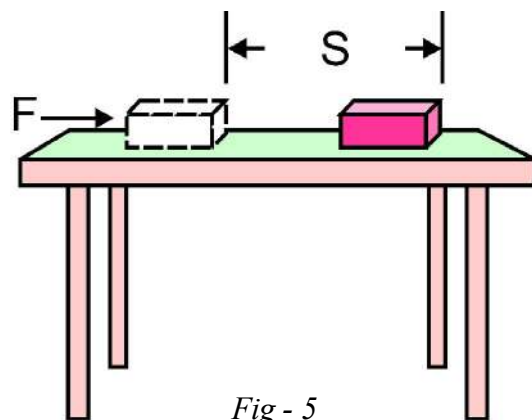

Fig - 5

Suppose that a constant force (F) acts on an object and object is moved through a distance (s) along the direction of the force (F) as shown in fig.- 5.

In science, we define work to be equal to the product of the force (F) and the displacement (s) moved along the direction of the force.

Work done = Force x Displacement.

$$W = FS$$

This formula for work is used in only translatory motion of the object.

Work has only magnitude but no direction. So work is a scalar.

We measure force (F) in newtons (N) and distance (S) in meters (m). In equation $W=FS$, if $F=1$ and $S=1$ then the work done by the force will be '1 N-m'. Hence the unit of work is 'newton-meter' (N-m) or 'joule' (J).

Thus 1 joule (J) is the amount of work done on an object when a force of 1 newton (1N) displaces it by 1m along the line of action of the force.

Look at the equation $W = FS$

- What would be the work done when the force on the object is zero?
- What would be the work done when the displacement of the object is zero?
- Can you give some examples, where the displacement of the object is zero?



Think and discuss

- A wooden chair is dragged on the level floor and brought to the same place. Let the distance covered be 's' and frictional force acted on the chair by the floor be 'f'. What is the work done by the frictional force ?

Example 1

A boy pushes a book kept on a table by applying a force of 4.5 N. Find the work done by the force if the book is displaced through 30 cm along the direction of push.

Solution

Force applied on the book (F) = 4.5 N
Displacement (s) = 30 cm = $(30/100)$ m
= 0.3m

$$\begin{aligned}\text{Work done, } W &= FS \\ &= 4.5 \times 0.3 \\ &= 1.35 \text{ J}\end{aligned}$$

Example 2

Calculate the work done by a student in lifting a 0.5 kg book from the ground and keeping it on a shelf of 1.5 m height. ($g=9.8 \text{ m/s}^2$)

Solution

The mass of the book = 0.5 kg
The force of gravity acting on the book is equal to 'mg'
That is $mg = 0.5 \times 9.8$
= 4.9 N

The student has to apply a force equal to that of force of gravity acting on the book in order to lift it.

Thus force applied by the student on the book, $F = 4.9 \text{ N}$

Displacement in the direction of force,

$$S = 1.5\text{m}$$

$$\begin{aligned}\text{Work done, } W &= FS \\ &= 4.9 \times 1.5 \\ &= 7.35 \text{ J}\end{aligned}$$

In the situation mentioned in fig.- 5 the displacement of the object is in the direction of the force. But there are certain cases where the displacement of the object may be in a direction opposite to the force acting on it.

For example if a ball is thrown up (Fig-6), the motion is in upward direction, whereas the force due to earth's gravity is in downward direction.

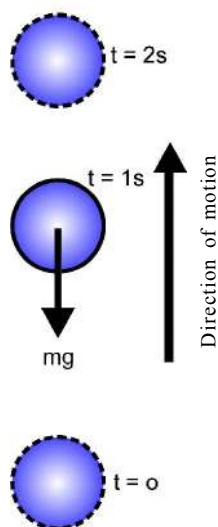

Fig-6
(Position of ball at various instants while moving up.)

- What happens to the speed of the ball while it moves up?
- What is the speed at its maximum height?
- What happens to the speed of the ball during its downward motion?

Similarly the ball moving on plain ground (Fig-7) will get stopped after some time due to frictional force acting on it in opposite direction.

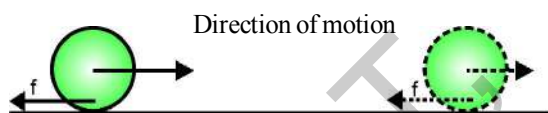

Fig - 7

If the force acting on an object and displacement are in opposite directions then the work done by the force is taken as negative.

$$W = -FS$$

If work has positive value, the body on which the work has been done would gain energy.

If work has negative value, the body on which the work has been done loses energy.



Think and discuss

Lift an object up from the ground. Work done by the force exerted by you on the object moves it in upward direction. Thus the force applied is in the direction of displacement. However there exists a force of gravitation on the object at the same time

- Which one of these forces is doing positive work?
- Which one is doing negative work?
- Give reasons.

Example - 3

A box is pushed through a distance of 4m across a floor offering 100N resistance. How much work is done by the resisting force?

Solution

The force of friction acting on the box,
 $F = 100\text{N}$

The displacement of the box,
 $S = 4\text{m}$

The force and displacement are in opposite directions. Hence work done on the box is negative.

$$\begin{aligned} \text{That is, } W &= -FS \\ &= -100 \times 4 \\ &= -400 \text{ N-m (or)} \\ &= -400 \text{ J} \end{aligned}$$

Example 4

A ball of mass 0.5 kg thrown upwards reaches a maximum height of 5m. Calculate the work done by the force of gravity during this vertical displacement considering the value of $g = 10\text{m/s}^2$.

Solution

Force of gravity acting on the ball,

$$F = mg = 0.5 \times 10 = 5\text{N}$$

Displacement of the ball, $S = 5\text{m}$

The force and displacement are in opposite directions. Hence work done by the force of gravity on the ball is negative.

$$\begin{aligned}W &= -FS \\ &= -5 \times 5 \\ &= -25\text{ J}\end{aligned}$$

10.3 Idea of Energy

The word Energy is very often used in daily life in various occasions like 'He is more energetic' 'I am so tired and lost my energy', 'Today I am feeling more energetic than yesterday' etc.

- What is energy?
- How can we decide that an object possess energy or not?

Let us consider the following cases

Case -1

A metal ball kept in a ceramic plate is raised to a certain height from the plate and allowed to fall on it.

- What will happen to the plate? Why?

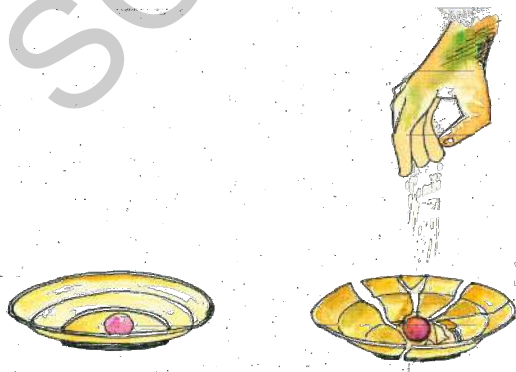

Fig - 8

Case -2

A toy car is placed on floor without winding the key attached to it and the same toy car placed on the floor after winding the key attached to it.



Fig - 9 : A Toy Car

- What changes do you notice? Why?

In case -1 you might have noticed that the metal ball does no work when it rests on the surface of the plate but is able to do some work when it is raised to a height.

Similarly in case -2 you may notice that the toy is at rest before winding the key but the same toy moved, when the key attached to it is wound up. Here the work done is due to energy.

Children may not be able to lift 25 kg rice bag but elders can do that.

- What could be the reason?

You may observe many such situations where the capacity to do work changes from person to person.

Similarly the capacity of doing work by an object on another object depends on position and state of the object which is doing work. Thus an object acquires energy through different means and is able to do work.

10.3.1 Energy transfer and the work

We learned in previous paragraphs, that we need energy to do any work and a person doing work spends some energy while doing the work i.e. the person doing the work loses some energy.

- Where does this energy go?
- Is there any energy transfer between the object doing the work and the object on which work has been done?
- Can any force do work without energy transfer?

In science, we consider work has been done only when there is a change in the position of the object. The object is able to change its position due to the energy transferred to it by the force doing the work. Thus whenever work is done on an object its energy either increases or decreases.

For example if we push a wooden block which is kept on a table, it starts moving due to the work done on it and as a result it gains kinetic energy.

Activity-2

Understanding the increase and decrease in energy of an object

Take a hard spring and keep it on the table as shown in the fig.- 10.

Now compress the spring with your palm and release it after few seconds. Observe the changes in its position, state and size after compressing the spring and releasing it.

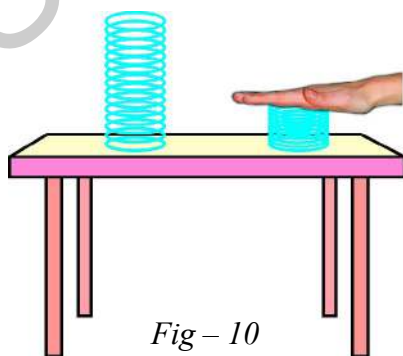

Fig - 10

You will notice that when spring is being compressed there is a change in its size. When it is released it gains some energy and may even jump from the table. The work done by your palm on the spring increases its energy and makes it to jump away from the table.

Thus we can conclude that the object which does work loses energy and the object on which work has been done gains energy. If negative work is done on an object, its energy decreases. For example, when a ball moves on the ground the force of friction does negative work on the ball (because it acts in a direction opposite to the motion of the ball). This negative work done on the ball decreases its kinetic energy and makes it come to rest after some time.



Think and discuss

- What would happen if nature does not allow the transfer of energy? Discuss with few examples.

10.3.2 Kinetic energy

Activity-3

Understanding the energy of moving objects

Consider a metal ball and a hollow plastic block which are kept on a table side by side as shown in the fig.- 11 (a). Now suppose that the ball is separated from the block and brought to one end of the table as shown in the fig.- 11 (b) and pushed to roll on the table with speed 'v'.

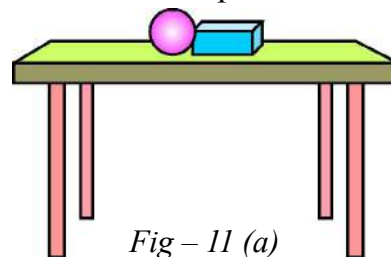

Fig - 11 (a)

- What will happen to block?
- What changes do you notice in the position and state of the ball and block when the ball is allowed to roll on the table?

You may notice that when the ball is pushed, it starts moving with speed of 'v' and hits the plastic block and displaces it from point A to B as shown in fig.- 11 (b). Thus a moving ball is more energetic than the ball at rest because the moving ball is able to do the work on plastic block to push it forward, whereas the same ball cannot do any work when it is at rest. In other words, a body possess more energy when it is moving than when it is at rest.

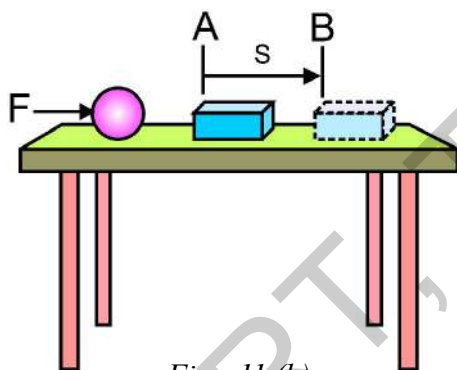

Fig - 11 (b)

Repeat this activity by pushing the metal ball with more force so as to increase its speed and observe the change in position of the plastic block on the table. You may notice that the increase in the speed of the ball increases its capacity of doing work on the block.

Thus we can conclude that a moving object can do work. An object moving faster can do more work than an identical object moving relatively slow.

The energy possessed by an object due to its motion is called kinetic energy.

The Kinetic energy of an object increases with its speed.

We come across many situations in our daily life where objects with kinetic energy do work on other objects. For example:

- When a fast moving cricket ball hits the wickets, it makes the wickets to tumble but if the swinging bat in the hands of a batsman hits the ball it reaches the boundary.
- A fast moving bullet pierces the target.
- Blowing wind moves the blades of the wind mill.

Objects like a falling coconut, a speeding car, a rolling stone, a flying aircraft, flowing water and running athlete etc, also possess kinetic energy.

- How can we find out as to how much energy is possessed by a moving body?

Mathematical expression for kinetic energy

We know that the kinetic energy of a body at rest is zero, but the kinetic energy of a body moving with certain velocity is equal to the work done on it to make it acquire that velocity from rest.

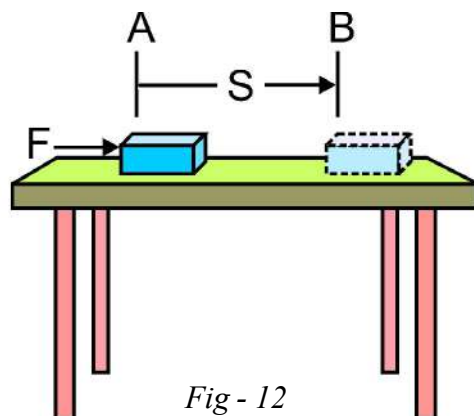

Fig - 12

Let us assume that an object of mass (m) is at rest on a smooth horizontal plane as shown in fig.-12. Let it be displaced through a distance 's' from the point A to B by a force (F) acting upon it in the direction of the displacement. In the horizontal direction the net force F_{net} is equal to the applied force F .

The work done on the object by the net force $W = F_{\text{net}} S = F S$ — (1)

Let the work done on the object cause a change in its velocity from 'u' to 'v' and the acceleration produced be 'a'.

In the chapter **motion** we studied about equations of uniform accelerated motion. The relation between initial velocity 'u', final velocity 'v', acceleration 'a' and displacement 's' is given by

$$v^2 - u^2 = 2 a s \quad \text{or} \quad s = \frac{(v^2 - u^2)}{2a} \quad \text{--- (2)}$$

We know by Newton's second law of motion

$$F_{\text{net}} = ma \quad \text{--- (3)}$$

From equations (1), (2) and (3)

$$W = \frac{ma(v^2 - u^2)}{2a}$$

$$W = \frac{1}{2} m (v^2 - u^2)$$

This is called work - energy theorem.

As we have assumed that object is at rest, its initial velocity $u = 0$, then

$$W = \frac{1}{2} m v^2$$

Thus the work done on the object is equal to $\frac{1}{2} m v^2$

We know that Kinetic Energy of a body moving with certain velocity is equal to work done on the object to acquire that velocity from rest.

Thus the kinetic Energy (K.E.) possessed by an object of mass 'm' and moving with velocity 'v' is equal to $\frac{1}{2} m v^2$

$$\text{K.E.} = \frac{1}{2} m v^2$$



Think and discuss

- Why is it easier to stop a lightly loaded truck than heavier one that has equal speed.
- Does the Kinetic energy of a car change more when it goes from 10 m/s to 20 m/s or when it goes from 20 m/s to 30 m/s.?

Example 5

Find the kinetic energy of a ball of 250 g mass, moving at a velocity of 40 cm /s.

Solution

Mass of the ball, $m = 250\text{g} = 0.25 \text{ kg}$

Speed of the ball, $v = 40 \text{ cm / s} = 0.4 \text{ m / s}$

Kinetic Energy,

$$\text{K.E.} = \frac{1}{2} (0.25) \times (0.4)^2 = 0.02 \text{ J}$$

Example 6

The mass of a cyclist together with the bicycle is 90 kg. Calculate the work done by cyclist if the speed increases from 6km /h to 12 km / h.

Solution

Mass of cyclist together with bike,

$$m = 90 \text{ kg.}$$

Initial velocity, $u = 6 \text{ km/h} = 6 \times (5/18)$

$$= 5/3 \text{ m/s}$$

Final velocity, $v = 12 \text{ km/h} = 12 \times (5/18)$

$$= 10/3 \text{ m/s}$$

Initial kinetic energy

$$\begin{aligned} \text{K.E}_{(i)} &= \frac{1}{2} mu^2 \\ &= \frac{1}{2} (90) (5/3)^2 \\ &= \frac{1}{2} (90) (5/3) (5/3) \\ &= 125 \text{ J} \end{aligned}$$

Final kinetic energy,

$$\begin{aligned} \text{K.E}_{(f)} &= \frac{1}{2} m v^2 \\ &= \frac{1}{2} (90) (10/3)^2 \\ &= \frac{1}{2} (90) (10/3) (10/3) \\ &= 500 \text{ J} \end{aligned}$$

The work done by the cyclist = Change in

$$\begin{aligned} \text{kinetic energy} &= \text{K.E}_{(f)} - \text{K.E}_{(i)} \\ &= 500 \text{ J} - 125 \text{ J} = 375 \text{ J.} \end{aligned}$$

10.3.3 Potential energy

Activity-4

Understanding potential energy

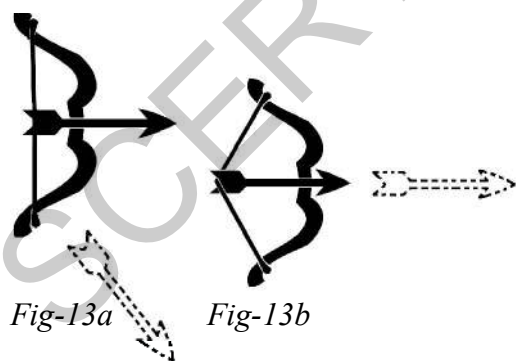

Take a bamboo stick and make a bow as shown in the fig.- 13 (a). Place an arrow made of a light stick on it with one end supported by the string of the bow as shown in fig.-13 (a) and stretch the string gently and release the arrow.

- What do you notice?

Now place the arrow on the bow with one end supported by the string and stretch the string applying more force and release the arrow as shown in fig.-13 (b)

- What differences do you notice in these two instances with respect to motion of arrow?
- Is there any change in the shape of the bow when the string is stretched by applying more force?

You may notice that in the first instance, fig.-13(a), when you release the arrow it gets separated from the bow and falls down on ground. But in second instance, fig.-13(b), you will notice the arrow flies with great speed into the air.

From this activity we can conclude that the bow in normal shape is not able to push the arrow but when we stretch the string, it acquires energy to throw the arrow into air with a great speed. The energy acquired by the bow due to change in its shape is known as its potential energy.

- Where does the bow get this energy from?
- Why is it not able to throw off the arrow in the first case?
- Can we increase the potential energy of the bow?

Discuss with friends about changes you need to make to the bow for increasing its potential energy.

In the first instance of above activity, you have gently stretched the string of the bow. Thus the work done by the force on the bow is negligible and energy transferred to the bow due to this work is also negligible. Hence the bow is not able to push the arrow.

In the second instance, you have applied more force on the string to stretch it. Thus the work done by you on bow changed its shape and it acquires large amount of energy. This energy is stored as potential energy in the bow which is responsible for throwing the arrow into air with a great speed.

In our daily life we come across many such situations where the work done on an object is stored as potential energy in it and used to do various other works.

For example the work done in winding the key of toy car is stored as potential energy in it and forces the car to move on the ground when released.

Do the following activities for the better understanding of potential energy.

Activity-5

Observing the energy in stretched rubber band

Take a rubber band hold it at one end and pull it from the other end and then release the rubber band at one of the ends.

What happens?

Activity-6

Observing the energy in an object at some height

Take a heavy ball. Drop it on a thick bed of wet sand from different heights from 25cm to 1.5 m. Observe the depression created by the ball on the bed of sand.

Compare depths of these depressions.

- What do you notice?
- Is there any relation to the depth of depression and the height from which ball was dropped?

In above activity we can observe that objects also acquire energy sometimes due to change in position.

Let us consider the following example

We use a hammer to drive nails into a plank. If a hammer is placed just on the tip of a nail, it hardly moves into the plank.

But if the hammer is raised to a certain height and then allowed to fall on the nail, we observe that the nail is pushed some distance into the plank.

Thus the energy of hammer is increased when it is raised to a certain height. This energy is due to the special position (height) of the hammer.

The energy possessed by an object because of its position or shape is called its "**potential energy**"

Potential energy of an object at height (or) Gravitational potential energy

An object increases its energy when it is raised through a height. This is because of the work done on the object against gravity acting on it. The energy of such an object is known as gravitational potential energy.

The gravitational potential energy of an object at a point above the ground is defined as the work done in raising it from the ground to that point against gravity.

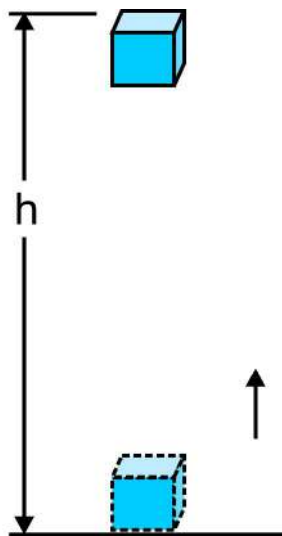

Fig-14

Consider an object of mass 'm' raised to height 'h' from the ground. A force is required to do this. The minimum force required to raise the object is equal to the weight of the object (mg). The object gains energy equal to the work done on it. Let the work done on the object against gravity be 'W'.

That is Work done,

$$\begin{aligned} W &= \text{force} \times \text{displacement} \\ &= mg \times h \\ &= mgh. \end{aligned}$$

Since the work done on the object is equal to ' mgh ' an energy equal to ' mgh ' units is gained by the object. This is the potential energy of the object at a height 'h'.

$$\text{P.E.} = mgh.$$



Think and discuss

- Does the international space station have gravitational potential energy ?

Example 7

A block of 2 kg is lifted up through 2m from the ground. Calculate the potential energy of the block at that point. [Take $g=9.8\text{m/s}^2$]

Solution

Mass of the block, $m = 2 \text{ kg}$

Height raised, $h = 2 \text{ m}$

Acceleration due to gravity, $g = 9.8 \text{ m/s}^2$

Potential Energy of the block,

$$\begin{aligned} \text{P.E.} &= mgh \\ &= (2)(9.8)(2) \\ &= 39.2 \text{ J} \end{aligned}$$

Example 8

A book of mass 1 kg is raised through a height 'h'. If the potential energy increased by 49 J, find the height raised.

Solution

The increase in potential energy = mgh

That is, $mgh = 49 \text{ J}$

$$(1)(9.8)h = 49 \text{ J}$$

The height raised, $h = (49) / (1 \times 9.8)$
 $= 5 \text{ m}$

10.4 Mechanical energy

The sum of the kinetic energy and the potential energy of an object is called its mechanical energy.

Consider the following example.

The kinetic energy of an aeroplane at rest is zero. Its potential energy when it is on ground is also considered as zero. Thus its mechanical energy is zero while it rests on the ground. When the same aeroplane flies it has kinetic energy as well as potential energy, the sum of these energies gives the total mechanical energy of the aeroplane in flight.

Conservation of energy

We find in nature a number of instances of conversion of energy from one form to another form. Sun is the big source of energy in nature. The solar energy from the Sun is converted into various forms like light energy, heat energy, wind energy etc.

Apart from this, we observe various instances of energy conversions in day to day activities, like conversion of electrical energy into heat energy by Iron box, chemical energy into light energy by a torch etc.

Activity-7

Listing the energy conversions in nature and in day to day life

Discuss various ways of energy conversions in nature as well as in our day to day activities and make a separate list of situations for natural conversions of energy and energy conversions in day-to-day life and write them in table-2, table-3.

Table -2: Energy conversions taking place in nature

S.No.	Situation of energy conversion in Nature
1	Heat energy from the Sun used for preparing food by plants gets converted into chemical energy.
2	
3	
4	

Table -3 Energy conversions taking place in day to day activities.

S.No.	Situation of energy conversion	Gadgets/appliances used for energy conversion
1	Conversion of electrical energy into mechanical energy	Electric fan
2		
3		
4		

Discuss about the following questions with your friends

- How do green plants produce food?

- How are fuels like coal and petroleum formed?
- What kind of energy conversions sustain the water cycle in nature?

We see other energy conversions in nature, for example snow deposited at altitudes melts and the water so formed flows down to seas. In the process, its potential energy is converted into kinetic energy. We convert the kinetic energy of water to electrical energy in hydroelectric power plants.

Dead plants buried deep below the earth's surface for millions of years get converted to fuels like petroleum and coal, which have chemical energy stored in them.

The food we eat comes from plant sources or animal sources which in turn take plant parts as their food.

When we eat food, several chemical processes take place and the chemical energy stored in food gets converted in to various forms needed by the body. For example when we walk, run, exercise etc., the energy from food is used for kinetic energy.

Activity - 8

Conservation of mechanical energy

Take a long thread say 50-60cm long and attach a small heavy object like a metal ball at one end, tie other to a nail fixed to the wall as shown in the fig- 15.

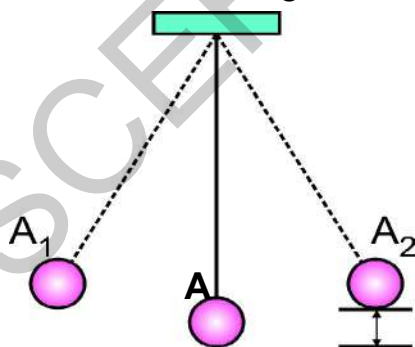

Fig-15

Now pull the object or bob of the pendulum to one side to the position A_1 (Fig-15) and release it.

What do you notice?

- You may notice that, the bob swings towards opposite side and reaches the point A_2 . It repeats this motion over and over again.
- The potential energy of the bob is minimum at A and reaches maximum at A_1 because the height of the bob is maximum at that position.
- When the bob is released from this point (A_1), its potential energy decreases and kinetic energy starts increasing slowly.
- When the bob reaches the position A its kinetic energy reaches maximum and potential energy becomes minimum.
- As the bob proceeds from A to A_2 its potential energy increases slowly and becomes maximum at A_2 .

If we neglect small loss of energy due to air resistance, the sum of potential energy and kinetic energy remains constant at any point on the path of motion during the oscillation of the pendulum.

Thus the total mechanical energy in the system of pendulum remains constant. This is called conservation of mechanical energy.

Thus energy can neither be created nor destroyed. It can only be changed from one form to another.

This is called law of conservation of energy.

When a ball is dropped from a height its gravitational potential energy decreases, but as the ball comes into motion, its kinetic energy increases. Thus a free-fall body possess both potential energy and kinetic energy during its fall to the ground.

Does the conservation of energy apply for the system of free-fall body? How?

Let us find.

Activity-9

Calculating the total energy of freefall at different heights

An object of mass 20 kg is dropped from a height of 4m. Compute the potential and kinetic energy in each case given in the following table and write the values in respective column of the table. (Take $g = 10 \text{ ms}^{-2}$.)

Table-4

Height at which object located in meters (m)	Velocity of object at different height [in m/s]	Potential energy $E_p = mgh$ [in Joules (J)]	Kinetic energy $E_k = \frac{1}{2}mv^2$ [in Joules (J)]	Total energy $(E_p + E_k)$ [in Joules (J)]
4.0	0			
3.55	3			
3.0	$\sqrt{20}$			
2.35	$\sqrt{33}$			
0.8	8			

- What do you say about total energy of system of freely falling body?
- Is the mechanical energy conserved in the system?

Power

In our day to day life we observe many situation where same activity is being completed in different time intervals. For example a hefty rickshaw puller is able to reach the destination in less time when compared other thinner rickshaw puller. Sometimes we notice that a grinder in our home takes more time to grind 1kg of 'dal' when compared to the grinder in the neighbours house.

- Do all of us do work at the same rate?
- Is the energy spent by the force doing work the same every time?
- Do machines consume or transfer energy at the same rate every time while doing a particular work?

Let us consider the following example.

- Raheem wanted to do some repairs in the first floor of his building.



Think and discuss

- Someone wants to sell you a super ball claims that it will bounce to a height greater than the height from which it is dropped. Would you buy this ball? If yes explain, if not explain.
- A ball, initially at the top of the inclined hill, is allowed to roll down. At the bottom its speed is 4 m/s. Next the ball is again rolled down the hill, but this time it does not start from rest. It has an initial speed of 3 m/s. How fast is it going when it gets to the bottom?

He brought 100 bricks as advised by the mason. A labourer was asked to shift these bricks from ground floor to first floor. The labourer completed the work of shifting bricks to first floor in one hour and asked Rs 150/- for the work.

Next day the mason asked Raheem to bring 100 bricks more to complete the repair work. Raheem brought another 100 bricks and assigned the work of shifting bricks to some another labourer. He completed the work and demanded Rs 300/- for completing the assigned work. Raheem said that he paid Rs 150/- to the labourer the day before. But the labourer argued that he worked more hours hence he was eligible for more money.

- Whose argument is correct?
- Is work done in two cases same?
- Why is there a change in rate of doing work?

In the above example the amount of work done is same in both cases. But the time taken to complete the work is different. This means that rate of doing work is different.

A stronger person as in the first case of above mentioned example, may do certain work in relatively less time compared to another person, similarly a powerful machine can do a work assigned to it in relatively short time compared with another machine.

We talk about the power of machines like motorbikes, motorcar, water pumping motors etc., the speed at which these machines do work is the basis for their classification. Power is a measure of the rate of doing work, that is how fast or how slow work is done.

Power is defined as the rate of doing work or rate of transfer of energy.

If an agent does a work W in time t , then power is given by

$$\text{Power} = \frac{\text{Work}}{\text{Time}}$$

$$P = \frac{w}{t}$$

The unit of power is 'watt' and denoted by symbol 'W'

1 watt is the power of an agent, which does work at the rate of 1 joule per second.

We express larger rate of energy transfer in kilowatts (kW)

1 kilowatt (kW)	1000 watts (W)
1kW	1000 J. s ⁻¹



Think and discuss

- The work done by a force F_1 is larger than the work done by another force F_2 . Is it necessary that power delivered by F_1 is also larger than that of F_2 ? Why?

Example 9

A person performs 420 J of work in 5 minutes. Calculate the power delivered by him.

Solution

Work done by the person, $W = 420$ J

Time taken to complete the work,

$$t = 5 \text{ min} = 5 \times 60\text{s} = 300\text{s}$$

$$\text{Power delivered, } P = \frac{w}{t}$$

$$= \frac{420}{300} = 1.4 \text{ W}$$

Example 10

A woman does 250 J of work in 10 seconds and a boy does 100 J of work in 4 seconds. Who delivers more power?

Solution

$$\text{Power, } P = \frac{w}{t}$$

$$\text{Power delivered by woman} = \frac{250}{10} = 25\text{W}$$

$$\text{Power delivered by boy} = \frac{100}{4} = 25\text{W}$$

Both woman and boy deliver same power. That is, rate of doing the work by woman and boy are equal.

10.5 SOURCES OF ENERGY

In activity 8, we have learnt that energy can be transformed from one form to another. Energy is of different forms and one form can be converted to another form. Example, observe fall of a coconut from a coconut tree. Potential energy of coconut gets converted into Kinetic energy. In this case the source for energy conversion is gravitational force. From this example we also understand that the energy transformations need a source responsible for their transformations.

A source of energy is one which can provide adequate amount of energy in a convenient form over a long period of time.

- What is a good source of energy?

Good source of energy may be understood based on the following features:

- That does a large amount of work per unit volume or unit mass of the source.
- That is cheap and easily available.
- That which is easier to use, store and transport.
- That is most economical and that causes no or minimum pollution.

Fuels:

- What is the source of energy to cook food?
- What is the source of energy to ride your vehicle?

- What is the source of energy to run a thermal power plant?
- What do you call these sources of energy?

We use LPG, Kerosene, Wood, Petroleum, coal, etc..as sources of energy for doing the above mentioned works. These sources of energy are known as fuels.

- Where do we get most of these fuels?

We know that most of these fuels can be obtained from earth crust. These fuels are known as fossil fuels.

- How are these fossil fuels formed?

Plants, animals and other living organism after their death got buried under the soil due to floods and other natural disaster for long period of the time. During course of time more soil, mud and rock sediments deposited over them. Due to absence of oxygen, high pressure, heat and action of bacteria, this organic matter convert into fossil fuels.

- What could be the main source of energy which helps to form fossil fuels?

We know that plants and animals grow using solar energy. This solar energy was trapped in this organic matter through natural processes millions of years ago.

- Do you think that these fuels get exhausted, if we use them continuously for a long time.
- What are other alternatives if these fuels are exhausted?

These fossil fuels cannot be reproduced by any artificial methods. They cannot be quickly replaced if once exhausted. So these are called non-renewable sources of energy.



Think and Discuss

Is the firewood obtained by cutting of trees renewable or non renewable source of energy? Why?

Renewable sources of energy

- Is there any alternate source of energy which cannot be exhausted?
- What could be the methods to get energy from these sources?

We know that Sun is the main source of energy. We already discussed that the fossil fuels are also formed due to the solar energy trapped in fossils.

10.5.1. Solar Energy:

Sun is the main source of energy. The energy received from Sun is known as solar energy. The sun has been radiating an enormous amount of energy at the present

rate nearly 5 billion years and will continue radiating energy at that rate for about 5 billion years more. Only a little amount of solar energy i.e. nearly 47% is only reaching the earth and the remaining is reflected back into atmosphere. India is receiving energy more than 5000 trillion KWH during a year. Under clear cloudless sky conditions, the daily average of solar energy varies from 4 to 7 KWH/m² in our country.



Fig. 16

Scientists have developed devices to use solar energy as a source of energy for cooking, electrical needs, etc. The devices are mainly solar cooker, solar water heater, solar cells, etc.

Solar cells

A solar cell converts energy from sunlight into electrical energy. A solar cell is made up of sandwiching a Silicon – boron layer and Silicon-arsenic layer. This cell can trap a very little amount of electricity. Hence a large number of cells are joined together in series to form a solar panel.

- Discuss various uses of solar panel.
- What are the advantages and disadvantages of solar energy?

10.5.2. Bio mass energy

Bio mass is organic material that comes from plants and animals and it is a renewable source of energy.

Bio mass contains stored energy from the Sun. Plants absorb the Sun's energy in a process called photosynthesis. When bio mass is burned, the chemical energy in bio mass is released as heat. Bio mass can be burned directly. It can also be converted into Coal, Petroleum, Cow dung Cakes, Bio gass etc. Fuels like Coal, Petroleum are called as fossil fuels.

2(a) Bio gas

‘Biogas’ is a renewable source of energy. It is produced mainly from cow dung, sewage, crop residues, vegetable wastes etc. It contains about 65% of methane and widely used as fuel for cooking. The slurry obtained as a by-product, left in the biogas plant after the biogas is used up can be used as a manure, which is rich in nitrogen and phosphorous.



Fig. 17

10.5.3. Energy from Sea

The energy from the sea can be obtained mainly in two forms. (a) Tidal energy, and (b) Ocean Thermal Energy.

10.5.4 Tidal Energy

During the high tide, the water from sea can be made to sent into a reservoir of the barrage and turns turbines. The turbines then turn the generators to produce electricity.



Fig. - 18

- Discuss the advantages and disadvantages of tidal energy.

Ocean Thermal Energy (OTE)

Heat from the sun is absorbed by the water on the surface of ocean, but at deeper levels of ocean, the temperature is very less. So, there is temperature difference between the water ‘at the surface of ocean’ and ‘at deeper levels’. This difference in temperature is called Ocean Thermal Energy (OTE). The OTE can be converted into electrical energy by using Ocean Thermal Energy Conversion (OTEC) plants.

10.5.5 Geo Thermal Energy

The interior of the earth is very hot. Water seeping down deep into the earth is turned into steam and this can be supplied to homes for heating purposes and for generating electricity. Electricity produced in this way is very less cost than to other sources, and also pollution free.



Fig. 19

10.5.6 Wind energy

Moving air is called wind. Wind has kinetic energy. The energy of wind is harnessed by using wind mills.



Fig. 20

A wind mill consists a big fan like blades fixed to tall poles at very higher places, such that they can rotate freely

when wind blows. A dynamo is attached to the shaft of blades, so the mechanical energy produced by rotating wind mill will be converted into electrical energy by the dynamo.

The electrical energy produced by these wind mills is pollution free.

10.5.7 Atomic Energy

Atomic energy is also known as nuclear energy. The physical reaction which involves changes in nucleus of an atom is called a nuclear reaction. The energy released during a nuclear reaction is called nuclear energy. This nuclear energy can be obtained by two types of nuclear reactions. 1. Nuclear fission and 2. Nuclear fusion.

I. Nuclear fission

The process in which heavy nucleus of a radioactive atom (Ex: Uranium) splits up into smaller nuclei when bombarded with low energy neutrons is called nuclear fission. A small change in the nucleus of heavy atoms releases a tremendous amount of energy.

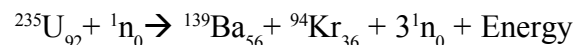

This energy is in the form of heat. This heat energy is used to produce electricity in nuclear power plants. In India, the nuclear power plants are situated at Tarapur (Maharashtra), Rana pratap sagar (Rajasthan), Kalpakam (Tamilnadu), Narora (Uttar Pradesh), Kaprapur (Gujarat), and Kaiga (Karnataka).

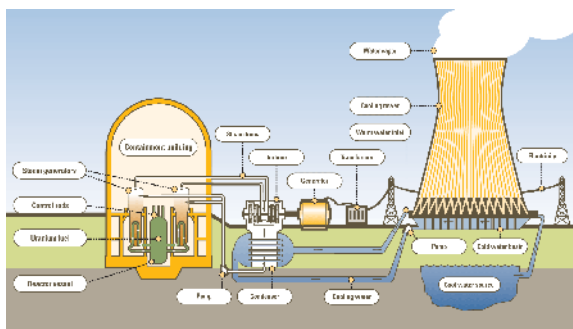
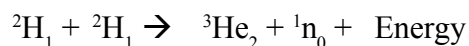

Fig. 21

10.6 Nuclear fusion

The process in which two nuclei of light elements combine to form a heavy nucleus is called nuclear fusion.



The energy released in this form can not be controlled. So this is not used as source for producing electricity. These nuclear fusion reactions which are taking place in Sun's core are the main source of Sun's energy.



Key words

Work, Energy, Transfer of energy, Sources of energy, Conservation of energy, Kinetic energy, Potential energy, Mechanical energy, Gravitational potential energy, Renewable sources of energy.



What we have learnt

- Two conditions need to be satisfied in order to say that work has taken place.
 - a) a force should act on the object and
 - b) the object must be displaced or there must be change in the position of the object.
- The work done by a force acting on an object is equal to the magnitude of force (F) multiplied by the distance moved (s). This formula for work is used in only translatory motion of the object.
- Work has only magnitude, no direction. So work is a scalar.
- If the force acting on an object and displacement are in opposite directions then the work done by the force is taken as negative.
- If work has positive value, the body on which work has been done would gain energy. If work has negative value, the body on which work has been done loses energy.
- Capability of doing work by an object or energy possessed by an object depends on position and state of the object which is doing work.

- Whenever work has been done on an object its energy either increases or decreases.
- Sun is the biggest natural source of energy to us. Many other sources are derived from it.
- The energy possessed by an object due to its motion is called kinetic energy.
- The energy possessed by an object because of its position or shape is called its potential energy.
- The sum of the kinetic energy and the potential energy of an object is called its mechanical energy.
- Energy can neither be created nor destroyed. It can only be changed from one form to another. This is the law of conservation of energy.
- Power is defined as the rate of doing work or rate of transfer of energy.



Improve your learning

I. Reflections on concepts

1. What is work according to science and write its units. (AS₁)
2. Give few examples where displacement of an object is in the direction opposite to the force acting on the object. (AS₁)
3. Write few daily life examples in which you observe conservation of energy. (AS₆)
4. Give some examples for renewable sources of energy (AS₁)



II. Application of concepts

1. A man carrying a bag of total mass 25kg climbs up to a height of 10m in 50 seconds. Calculate the power delivered by him on the bag. (AS₁) (Ans : 49J)
2. A 10 kg ball is dropped from a height of 10m. Find (a) the initial potential energy of the ball, (b) the kinetic energy just before it reaches the ground, and (c) the speed just before it reaches the ground. [$g=9.8 \text{ m/s}^2$] (AS₁) (Ans: 980J, 980J, 14m/s)
3. Calculate the work done by a person in lifting a load of 20 kg from the ground and placing it 1m high on a table. (AS₁) (Ans: 196N-m)
4. Find the mass of a body which has 5J of kinetic energy while moving at a speed of 2m/s. (AS₁) (Ans: 2.5 kg)

5. A cycle together with its rider weighs 100kg. How much work is needed to set it moving at 3 m/s. (AS₁) (Ans: 450J)
6. Which of the renewable sources of energy would you think suitable to produce your native place. Why? (AS₁)

III. Higher Order Thinking Questions

1. When you lift a box from the floor and put it on an almirah the potential energy of the box increases but there is no change in its kinetic energy. Is it violation of conservation of energy? Explain. (AS₁)
2. When an apple falls from a tree what happens to its gravitational potential energy just as it reaches the ground? After it strikes the ground? (AS₁)



Multiple choice questions

1. S.I. unit of work []
 a) N-m b) Kg-m c) N/m d) N-m²
2. The energy possessed by a body by virtue of its motion is called as []
 a) Potential energy b) Kinetic energy
 c) Attractive energy d) Gravitational energy
3. A person is climbing a ladder with a suitcase on his head. Then the work done by that person on that suitcase is []
 a) Positive b) Negative c) Zero d) Can not be defined
4. If you have lifted a suitcase and kept it on a table., then the work done by you will depend on []
 a) The path of the motion of the suitcase b) The time taken by you to do the work
 c) Weight of the suitcase d) Your weight.



Suggested Experiments

1. Conduct an experiment to prove the conservation of mechanical energy and write a report on it.
2. Conduct an experiment to calculate the total energy of a freely falling body at different heights.



Suggested Projects

1. How will the increasing energy needs and conservation of energy influence international peace, cooperation and security? Collect information on this and write a report.
2. Collect information about different sources of energy and write a report on the advantages and disadvantages in harnessing energy from these sources.
3. Make different models showing the harnessing energy from different energy sources.



Recall the experiments you did in Class 7 with the glass tumblers containing of cold water, lukewarm water and hot water. We understood that ‘hot’ and ‘cold’ are relative terms and that heat was a form of energy. We use the terms “Temperature and Heat” to describe these observations. These words, technically, have special meanings. In order to understand their meanings let us do some activities.

Activity-1

Take a piece of wood and a piece of metal and keep them in a fridge or ice box. After 15 minutes, take them out and ask your friend to touch them.

- Which is colder? Why?

When we keep materials in a fridge, they become cold i.e., they lose heat energy. The iron and wooden pieces were kept in the fridge for the same period of time but we feel that the metal piece is colder than the wooden piece.

- What could be the reason for this difference in coldness?
- Does it have any relation to the transfer of heat energy from our body to the object?

When you touch the metal or wooden piece, you feel that they are cold. This means that heat energy is being transferred from your finger to the pieces. When you remove your finger, you don't get a feeling of ‘coldness’. This means that when heat energy flows out of your body you get the feeling of ‘coldness’ and when heat energy enters your body you get a feeling of ‘hotness’. You can test this by bringing your finger near the flame of a matchstick!

So, if you feel that the metal piece is ‘colder’ than the wooden piece, it must mean that more heat energy flows out of your body when you touch the metal piece as compared to the wooden piece. In other words, the ‘degree of coldness’ of the metal piece is greater than that of the wooden piece.

The conventional definition of temperature is “the degree of hotness or coldness”.

We say that the metal piece is at a lower ‘temperature’ as compared to the wooden piece, when they are taken out of the fridge.

- Why does transfer of heat energy take place between objects ?
- Does transfer of heat take place in all situations?
- What are the conditions for transfer of heat energy?

Let us find out

11.1 Thermal equilibrium-heat and temperature

When two bodies are placed in thermal contact, heat energy will be transferred from the ‘hotter’ body to the ‘colder’ body. This transfer of heat energy continues till both bodies attain the same degree of hotness (or) coldness. At this stage, we say that the bodies have achieved ‘thermal equilibrium’. Thus, the state of thermal equilibrium denotes a state of a body where it neither receives nor gives out heat energy.

If you are not feeling either hot or cold in your surroundings, then your body is said to be in thermal equilibrium with the surrounding atmosphere. Similarly, the furniture in the room is in thermal equilibrium with air in the room. So we can say that the furniture and the air in the room are at the same temperature.

Heat

- What is temperature?
- How can you differentiate it from heat?

Let us find out

Activity-2

Take two glass tumblers and fill one of them with hot water and another with cold water. Now take a laboratory thermometer, observe the mercury level in it and note it in your book. Keep it in hot water. Observe changes in the mercury level. Note the reading.

- What change did you notice in the reading of the thermometer? (mercury level)?
- Did the mercury level increase or decrease?

Now place the thermometer in cold water and observe changes in the mercury level. Did the level decrease or increase?

We know that bodies in contact achieve thermal equilibrium due to transfer of heat energy. When you keep the thermometer in hot water you observe that there is a rise in mercury level. This happens because heat got transferred from the hotter body (hot water) to the colder body (mercury in thermometer). Similarly in the second case you will observe that the mercury level comes down from its

initial level because of the transfer of heat from mercury (hotter body) to water (colder body). Thus we define heat as follows:

“Heat is a form of energy in transit, that flows from a body at higher temperature to a body at lower temperature.”

The steadiness of the mercury column of the thermometer indicates that flow of heat between the thermometer liquid (mercury) and water, has stopped. *Thermal equilibrium* has been attained between the water and thermometer liquid (mercury). The thermometer reading at thermal equilibrium gives the “temperature”. Thus ‘temperature’ is a measure of thermal equilibrium.

If two different systems, A and B in thermal contact, are in thermal equilibrium individually with another system C (thermal contact with A and B), will the systems A and B be in thermal equilibrium with each other?

We know that if A is in thermal equilibrium with C, then they both have the same temperature. Similarly, B and C have the same temperature. Thus A and B will have the same temperature and would therefore be in thermal equilibrium with each other. (A, B and C are in thermal contact).

The SI unit of heat is joule (J) and CGS unit is calorie (cal). The amount of heat required to raise the temperature of 1 gram of water by 1°C is called calorie.

$$1\text{cal} = 4.186\text{ Joule}$$

The SI unit of temperature is kelvin (K). It can also be expressed as degree celsius (°C).

$$0^{\circ}\text{C} = 273\text{K}$$

- How would you convert degree celsius to kelvin?

Temperature in kelvin = 273 + temperature in degree celsius

$$K = 273 + T$$

Add 273 to the value of temperature in degree celsius to get the temperature on the kelvin scale.

Note: Temperature measured on Kelvin scale is called absolute temperature.

11.2 Temperature and Kinetic energy

Activity-3

Take two bowls one with hot water and second with cold water. Gently sprinkle grains of food colour on the surface of the water in both bowls. Observe the motion of the small grains of food colour.

- How do they move?
- Why do they move randomly?
- Why do the grains in hot water move more rapidly than the grains in cold water?

You will notice that the grains of food colour jiggle (move randomly). This happens because the molecules of water in both bowls are in random motion. We observe that the jiggling of the grains of food colour in hot water is more when compared to the jiggling in cold water.

We know that bodies possess kinetic energy when they are in motion.

As the speed of motion of particles (grain of food colour) in the bowls of water is different, we can say that they have different kinetic energies. Thus we conclude that the average kinetic energy of molecules / particles of a hotter body is greater than that of a colder body. So we can say that the temperature of a body is an indicator of the average kinetic energy of molecules of that body.

“The average kinetic energy of the molecules is directly proportional to the absolute temperature” ($KE \propto T$)

Activity-4

Take water in a container and heat it to 60°C . Take a cylindrical transparent glass jar and fill half of it with this hot water. Very gently pour coconut oil over the surface of the water. (Take care that the water and oil do not mix). Put a lid with two holes on the top of the glass jar. Take two thermometers and insert them through the holes of the lid in such a way that the bulb

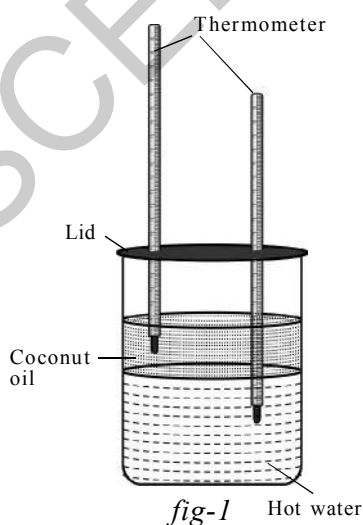

of one thermometer lies only inside the water and other lies only inside the coconut oil as shown in figure 1.

Now observe the readings of the two thermometers. The reading of the thermometer kept in water decreases, while, at the same time, the reading of the thermo-meter kept in oil increases.

- Why does this happen?

Because the average kinetic energy of the molecules of oil increases, while the average kinetic energy of the molecules of water decreases. In other words, the temperature of oil increases while the temperature of water decreases.

- Can you say that the water loses energy?

From the above discussion it is clear that, water loses energy while oil gains energy; because of the temperature difference between the water and oil. Thus some heat energy flows from water to oil. This means, the kinetic energy of the molecules of the water decreases while the kinetic energy of the molecules of oil increases.

- Can you now differentiate between heat and temperature based on the discussion we made of the above activities?

With activities 2, 3 and 4 we can differentiate heat and temperature as follows:

Heat is the energy that flows from a hotter body to a colder body. Temperature is a quantity that denotes which body is hotter and which is colder. So temperature determines *direction of heat (energy) flow*, whereas heat is the *energy* that flows.

11.3 Specific Heat

Activity 5

Take a large jar with water and heat it up to 80°C. Take two identical boiling test tubes with single-holed corks. One of them is filled with 50g of water and the other with 50g of oil, both at room temperature. Insert two thermometers through holes of the corks, one each into two test tubes. Now clamp them to a retort stand and place them in a jar of hot water as shown in figure 2. Note the initial temperature of oil and water.

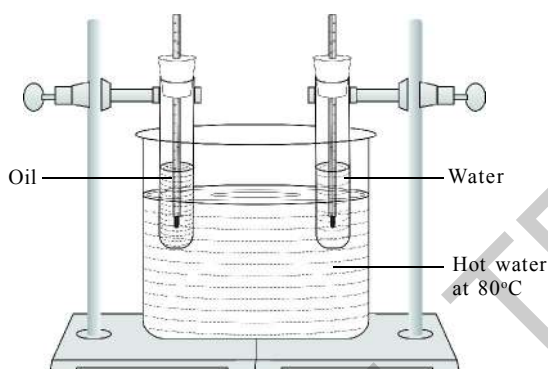

fig-2

Observe the readings of thermometers every three minutes. Note the readings in your notebook.

- In which test tube does the temperature rise quickly?
- Are the amounts of heat given to the water and oil same? How can you assume this?

We believe that the same amount of heat is supplied to water and oil because they are kept in the jar of hot water for the same interval of time.

We observe that the rate of rise in temperature of the oil is higher than that of the rise in temperature of the water.

- Why does this happen?

We conclude that the rate of rise in temperature depends on the nature of the substance.

Activity 6

Take two beakers of equal volume and take 250 grams of water in one beaker and 1 kg of water in another beaker. Note down their initial temperatures using a thermometer (initial temperatures should be the same). Now heat both beakers till the temperature of water in the two beakers rises to 60 °C. Note down the time required to raise the temperature of water to 60 °C in each beaker.

- Which beaker needed more time?

You will notice that you need more time to raise the temperature of 1 kg of water when compared to 250 grams of water. That means you need to supply more heat energy to greater quantity of water than lesser quantity of water for same change in temperature.

For same change in temperature the amount of heat (Q) absorbed by a substance is directly proportional to its mass (m)

$$Q \propto m \text{ (when } \Delta T \text{ is constant) } \dots(1)$$

Now take 1 litre of water in a beaker and heat it over a constant flame. Note the temperature changes (ΔT) for every two minutes.

- What do you notice?

You will notice that the change in temperature rise with time is proportional, that means, for the same mass (m) of water the change in temperature is proportional to amount of heat (Q) absorbed by it.

$$Q \propto \Delta T \text{ (when 'm' is constant) } \dots(2)$$

From equation (1) and (2), we get

$$Q \propto m\Delta T \Rightarrow Q = mS\Delta T$$

Where 's' is a constant for a given substance. This constant is called "specific heat" of the substance.

$$S = \frac{Q}{m\Delta T}$$

The specific heat of a substance is the amount of heat required to raise the temperature of unit mass of the substance by one unit.

- How much heat energy is required to raise the temperature of unit mass of substance by 1°C ?

Substance	Specific heat	
	In cal/g-°C	In J/kg-K
Lead	0.031	130
Mercury	0.033	139
Brass	0.092	380
Zinc	0.093	391
Copper	0.095	399
Iron	0.115	483
Glass(flint)	0.12	504
Aluminum	0.21	882
Kerosene oil	0.50	2100
Ice	0.50	2100
Water	1	4180
Sea water	0.95	3900

CGS unit of specific heat is cal/g-°C and SI unit of it is J / kg - K

$$1 \text{ cal/g- } ^\circ\text{C} = 1 \text{ kcal /kg-K} \\ = 4.2 \times 10^3 \text{ J/kg-K}$$

We have seen that the rise in temperature depends on the nature of the substance; hence the specific heat of a substance depends on its nature. If the specific heat is high, the rate of rise (or fall) in temperature is low for same quantity of heat supplied. It gives us an idea of the degree of 'reluctance' of a substance to change its temperature.

- Why is the specific heat different for different substances?

Let us find out.

We know that the temperature of a body is directly proportional to the average kinetic energy of particles of the body. The molecules of the system (body or substance) have different forms of energies such as linear kinetic energy, rotational kinetic energy, vibrational energy and potential energy between molecules. The total energy of the system is called *internal energy* of the system. When we supply heat energy to the system the heat energy given to it will be shared by the molecules among the various forms of energy.

This sharing will vary from substance to substance. The rise in temperature is high for a substance, if the maximum share of heat energy is utilised

for increasing its linear kinetic energy. This sharing of heat energy of the system also varies with temperature. That is why the specific heat is different for different substances.

If we know the specific heat of a substance, we can determine how much heat (Q) is needed to raise the temperature of a certain mass of the substance through certain degrees by using the equation $Q = ms\Delta T$

11.4 Applications of Specific heat capacity

1. The sun delivers a large amount of energy to the Earth daily. The water sources on Earth, particularly the oceans, absorb this energy for maintaining a relatively constant temperature. The oceans behave like “heat store houses” for the earth. They can absorb large amounts of heat at the equator without appreciable rise in temperature due to high specific heat of water. Therefore, oceans moderate the surrounding temperature near the equator. Ocean water transports the heat away from the equator to areas closer to the north and south poles. This transported heat helps moderate the climates in parts of the Earth that are far from the equator.
2. Water melon brought out from the refrigerator retains its coolness for a longer time than any other fruit because it contains a large percentage of water. (water has greater specific heat).
3. A samosa appears to be cool outside but it is hot when we eat it because the curry inside the samosa contains ingredients with higher specific heats. That’s why samosa is hot for longer time.

11.5 Method of mixtures

Activity - 7

Situation-1: Take two beakers of the same size and pour 200 ml of water in each of them. Now heat the water in both beakers till they attain the same temperature. If you pour this water from these two beakers into a larger beaker, what temperature could you expect the mixture to be? Measure the temperature of the mixture.

- What do you observe?
- What could be the reason for the fact you observed?

Situation-2: Now heat the water in one beaker to 90°C and the other to 60°C . Mix the water from these beakers in a larger beaker.

- What will the temperature of the mixture be?
- Measure temperature of the mixture. What did you notice?
- Can you give reasons for the change in temperature?

Situation-3: Now take 100 ml of water at 90°C and 200 ml of water at 60°C and mix the two.

- What is the temperature of the mixture?
- What difference do you notice in the change of temperature?

Let us find out.

Let the initial temperatures of the samples of masses m_1 and m_2 be T_1 and T_2 (the higher of the two temperatures is called T_1 , the lower is called T_2). Let T be the final temperature of the mixture.

The temperature of the mixture is lower than the temperature of the hotter sample but higher than the temperature of the colder sample. This means that the hot sample has lost heat, and the cold sample has gained heat.

The amount of heat lost by the hotter sample Q_1 is $m_1S(T_1 - T)$.

The amount of heat gained by the cooler sample Q_2 is $m_2S(T - T_2)$.

Since heat lost by the hotter sample is equal to the heat gained by the cooler sample (assuming no loss of heat) i.e

$$Q_1 = Q_2$$

which can be written as

$$m_1S(T_1 - T) = m_2S(T - T_2)$$

which can be simplified to

$$T = \frac{m_1T_1 + m_2T_2}{m_1 + m_2}$$

You will notice the temperatures of mixtures in situation – 2 and situation – 3 are not equal.

- Can you guess the reason for this?
- Can we find temperature of the mixture using a thermometer?

Principle of method of mixtures

When two or more bodies at different temperatures are brought into thermal contact, then net heat lost by the hot bodies is equal to net heat gained by the cold bodies until they attain thermal equilibrium. (If heat is not lost by any other process)

Net heat loss = Net heat gain

This is known as principle of method of mixtures.

11.6 Determination of Specific heat of a solid



Lab Activity

Aim: To find the specific heat of given solid.

Material required: calorimeter, thermometer, stirrer, water, steam heater, wooden box and lead shots.

Procedure: Measure the mass of the calorimeter along with stirrer.

Mass of the calorimeter, $m_1 = \dots\dots\dots$

Now fill one third of the volume of calorimeter with water. Measure its mass and its temperature.

Mass of the calorimeter plus water, $m_2 = \dots\dots\dots$

Mass of the water, $m_2 - m_1 = \dots\dots\dots$

Temperature of water in calorimeter, $T_1 = \dots\dots\dots$

Note: Calorimeter and water are at same temperature.

Take a few lead shots and place them in hot water or steam heater. Heat them upto a temperature 100°C . Let this temperature be T_2 .

Transfer the hot lead shots quickly into the calorimeter (with minimum loss of heat). You will notice that the mixture settles to a certain temperature after some time.

Measure this temperature T_3 and mass of the calorimeter along with contents (water and lead shots).

Mass of the calorimeter along with contents, $m_3 = \dots\dots\dots$

Mass of the lead shots, $m_3 - m_2 = \dots\dots\dots$

Since there is no loss of heat to surroundings, we can assume that the entire heat lost by the solid (lead shots) is transferred to the calorimeter and water to reach the final temperature.

Let the specific heats of the calorimeter, lead shots and water be S_c , S_l and S_w respectively. According to the method of mixtures, we know;

Heat lost by the solid = Heat gain by the calorimeter + Heat gain by the water

$$(m_3 - m_2) S_s(T_2 - T_3) = m_1 S_c(T_3 - T_1) + (m_2 - m_1) S_w(T_3 - T_1)$$
$$S_s = \frac{[m_1 S_c + (m_2 - m_1) S_w](T_3 - T_1)}{(m_3 - m_2)(T_2 - T_3)}$$

Knowing the specific heats of calorimeter and water, we can calculate the specific heat of the solid (lead shots).

Evaporation

When wet clothes dry, you will notice that water in the clothes disappears.

- Where does the water go?

Similarly, when the floor of a room is washed with water, the water on the floor disappears within minutes and the floor becomes dry.

- Why does water on the floor disappear after some time?

Let us see.

Activity 8

Take a few drops of spirit on your palm using a dropper.

- Why does your palm become colder?

Take a few drops of spirit (say 1 ml) in two petri dishes (a shallow glass or plastic cylindrical lidded dish used in the laboratory) separately. Keep one of the dishes containing spirit under a ceiling fan and switch on the fan. Keep another dish with its lid closed. Observe the quantity of spirit in both dishes after 5 minutes.

- What do you notice?

You will notice that spirit in the dish that is kept under the ceiling fan disappears, whereas you will find some spirit left in the dish that is kept in the lidded dish.

- What could be the reason for this change?

To answer the above questions, you need to understand the process of evaporation. The molecules of spirit that is kept in petri dish, continuously move with random speeds in various directions. As a result these molecules collide with other molecules.

During the collision they transfer energy to other molecules. When the molecules inside the liquid collide with molecules at the surface, the molecules at the surface acquire energy and may fly off from the surface.

Some of these escaping molecules may be directed back into liquid when they collide with the particles of air. If the number of escaping molecules is greater than the number returned, then the number of molecules in the liquid decreases. Thus when a liquid is exposed to air, the molecules at the surface keep on escaping from the surface till the entire liquid disappears into air. This process is called *evaporation*.

During the process of evaporation, the energy of the molecules inside the liquid decreases and they slow down. They transfer this energy to escaping molecules during the collisions.

“The process of escaping of molecules from the surface of a liquid at any temperature is called evaporation”

Let us determine the reason for faster evaporation of spirit kept under the fan. If air is blown over the liquid surface in an open pan or petri dish, the number of molecules returned is reduced to a large extent.

This is because any molecule escaping from the surface is blown away from the vicinity of the liquid. This increases the rate of evaporation. This is the reason why the spirit in petri dish, that is kept under ceiling fan evaporates quickly when compared to that kept closed. You will notice that clothes dry faster when a wind is blowing.

It means that the temperature of a system falls during evaporation. Evaporation is a surface phenomenon.

Activity 9

Effect of surface area, Humidity and wind speed on evaporation

Take 5ml of water each in a test tube and in a china dish separately and keep them under the fan. Take 5ml of water in another china dish and keep it in the cupboard.

Record room temperatures and time taken for evaporation of water in all three cases. If possible, repeat the activity on a rainy day and record your observations.

- In which case evaporation is fast?
- What do you infer about the effect of surface area and wind speed on evaporation?

You must have noticed that the rate of evaporation in china dish is faster.

Since evaporation is a surface phenomena, during evaporation process the particles escape from the surface of liquid. The increase in the surface area provides more scope for particles to escape from the surface. Hence, increases the rate of evaporation.

Humidity is another factor that effects evaporation. The amount of water vapour present in air is called humidity.

The air around us cannot hold more than a definite amount of water vapour at a given temperature.

If the amount of water vapour is high in air the rate of evaporation will decrease. So clothes dry slowly during rainy season but fast on a sunny and windy day.

Because of increase in wind speed, water vapour particles move away with the wind, decreasing the amount of water vapour in the surroundings.

We can also define evaporation as “the change of phase from liquid to gas that occurs at the surface of the liquid”. It is a cooling process, because the particles of liquid continuously give up their energy to the particles that are escaping from the surface.

Let us look at the following example.

- Why do we sweat while doing work?

When we do work, we spend our energy mostly in the form of heat energy from the body. As a result the temperature of the skin becomes higher and the water in the sweat glands starts evaporating. This evaporation cools the body.

Rate of evaporation of a liquid depends on its surface area, temperature and amount of vapour already present in the surrounding air.

- Does the reverse process of evaporation take place?
- When and how does it take place?

Let us find out.

11.7 Condensation

Activity 10

Place a glass tumbler on the table. Pour cold water up to half its height.

- What do you observe on the outer surface of the tumbler?
- Why do water droplets form on the outer side of the glass?

We know that the temperature of surrounding air is higher than the temperature of the cold water.

Air contains water molecules in the form of vapour.

When the molecules of water in air, during their motion, strike the surface of the glass tumbler which is cool; they lose their kinetic energy which lowers their temperature and they get converted into droplets.

The energy lost by the water molecules in air is gained by the molecules of the glass tumbler. Hence the average kinetic energy of the glass molecules increases. In turn the energy is transferred from glass molecules to the water molecules in the glass.

In this way, the average kinetic energy of water molecules in the tumbler rises. Hence we can conclude that the temperature of the water in glass increases. This process is called '*condensation*'. It is a warming process.

Condensation can also be defined as "the phase change from gas to liquid".

Let us examine a situation:

You feel warm after you finish your bath under the shower on a hot day. In the

bathroom, the number of vapour molecules per unit volume is greater than the number of vapour molecules per unit volume outside the bathroom. When you try to dry yourself with a towel, the vapour molecules surrounding you condense on your skin and this condensation makes you feel warm.

11.8 Humidity

Some vapour is always present in air. This vapour may come from evaporation of water from the surfaces of rivers, lakes, ponds and from the drying of wet clothes, sweat and so on. The presence of vapour molecules in air is said to make the atmosphere humid. The amount of water vapour present in air is called *humidity*.

11.9 Dew and Fog

In early morning, during winter, you might have noticed that water droplets form on window panes, flowers, grass etc.

- How are these water droplets formed?

Let us find out.

During winter nights, the atmospheric temperature goes down. The surfaces of window-panes, flower, grass etc, become still colder. The air near them becomes saturated with vapour and condensation begins. The water droplets condensed on such surfaces are known as *dew*.

If the temperature falls further, the whole atmosphere in that region contains a large amount of vapour. So the water molecules present in vapour condense on the dust particles in air and form small droplets of water.

These droplets keep floating in the air and form a thick mist which restricts visibility. This thick mist is called *fog*.

- Does the temperature of the water rise continuously if heat is supplied to it continuously?

11.10 Boiling

Activity 11

Take a beaker of water, keep it on the burner. Note the readings of thermometer for every 2 minutes.

- Did you see any rise or fall in the level of the surface of the water, in the beaker? Why?
- Does the temperature rise continuously?
- When does the rise in temperature of water stop?

You will notice that, the temperature of the water rises continuously, till it reaches 100°C . Beyond 100°C no further rise of temperature of water is seen. At 100°C , though supply of heat continues, the temperature does not increase further. We also observe a lot of bubbling at the surface of water at 100°C . This is what we call *boiling* of water

- Why does this happen?

Water is a solution, there are many impurities dissolved in it including some gases. When water or any liquid is heated, the solubility of gases it contains reduces. As a result, bubbles of gas are formed in the liquid (at the bottom and on walls of the vessel). Evaporation of water molecules from the surrounding causes these bubbles, to become filled with saturated vapour,

whose pressure increases as we increase the temperature of the liquid by heating. At a certain temperature, the pressure of the saturated vapour inside the bubbles becomes equal to the pressure exerted on the bubbles from the outside (this pressure is equal to the atmospheric pressure plus the pressure of the layer of water above the bubble). As a result, these bubbles rise rapidly to the surface and collapse at the surface releasing vapour present in bubbles into air at the surface. This process of converting the liquid into vapour (gas) continues as long as you supply heat. This appears as boiling of water for us.

“Boiling is a process in which the liquid phase changes to gaseous phase at a constant temperature at a given pressure.” This temperature is called boiling point of the liquid.

- Are the processes of evaporation and boiling the same?

As you have seen in activity – 8 and 10, the boiling of a liquid differs essentially from evaporation. Note that evaporation takes place at any temperature, while boiling occurs at a definite temperature called the boiling point. Let us recall your observation in activity – 10 that, when boiling process starts, the temperature of the liquid cannot be raised further, no matter how long we continue to heat it. The temperature remains constant at the boiling point until all of the liquid has boiled away.

In activity – 10, you have noticed that, while heating the water in the beaker, the temperature of water rises continuously till it reaches 100°C . But once boiling got started, no further rise of temperature is seen though supply of heat continues.

- Where does the heat energy supplied go?

This heat energy is used to change the state of water from liquid to vapour (gas). This is called *latent heat of vapourization*.

The heat energy required to change 1gm of liquid to gas at constant temperature is called latent heat of vapourization.

Consider a liquid of mass ‘m’ that requires heat energy of ‘Q’ calories to change from its state from liquid phase to gaseous phase. Then **Latent heat of vaporization** is $\frac{Q}{m}$. Latent heat of vaporization is denoted by ‘L’.

CGS unit of latent heat of vaporization is cal/gm and SI unit is J/kg.

The boiling point of water at standard atmospheric pressure (1atm) is 100°C or 373K and Latent heat of vaporization of water is 540 cal/gm.

Let us now consider the transformation of ice into water.

- Why does an ice cube get converted into water?

11.11 Melting

Activity 12

Take small ice cubes in a beaker. Insert the thermometer into ice cubes in the beaker. Observe the reading of the thermometer. Now start heating the beaker keeping it on a burner. Observe changes in the thermometer reading every 1 minute till the ice completely melts and gets converted into water.

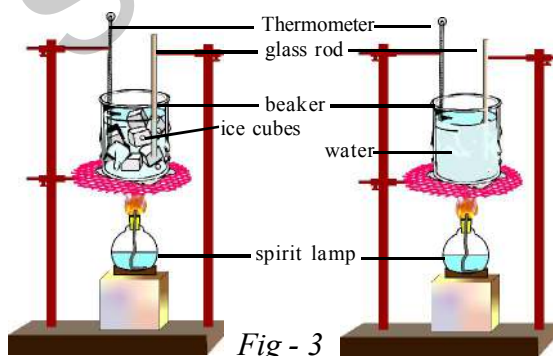

- What changes do you notice in the reading of thermometer as time passes by?

- Does the temperature of the ice change during the process of melting?

You will observe that the temperature of ice at the beginning is equal to or below 0°C. If the temperature of ice is below 0°C, it goes on changing till it reaches 0°C. When ice starts melting, you will notice no change in temperature though you are supplying heat continuously.

- Why does this happen?

The heat energy supplied to the ice increases the internal energy of the molecules of the ice. This increase in internal energy of molecules weakens the bonds as well as breaks the bonds between the molecules (H₂O) in the ice. That is why the ice (in solid phase) becomes water (in liquid phase). This process takes place at a constant temperature 0°C or 273K. This temperature is called *melting point*. This process of converting solid into a liquid is called “**Melting**”.

The temperature of the ice does not change during melting because the heat energy given to the ice is totally utilized in breaking the bonds between the water molecules.

The process in which solid phase changes to liquid phase at a constant temperature is called melting. This constant temperature is called melting point.

- How much heat energy is required to convert 1gm of ice to liquid?

The Heat energy required to convert 1gm of solid completely into liquid at a constant temperature is called *Latent heat of fusion*.

Consider a solid of mass m . Let heat energy Q be required to change it from the solid phase to liquid phase. The heat required to change 1gm of solid into liquid is $\frac{Q}{m}$.

Latent heat of fusion $L = \frac{Q}{m}$. The value of Latent heat of fusion of ice is 80cal/gm.



Do you know?

Strange behaviour of water

A liquid usually expands when it is heated but water behaves differently. Between 0°C to 4°C its volume shrinks. Same amount of water in solid ice occupies more volume than liquid water. Thus density of ice is less than the density of water. Hence ice floats on water rather than sinking. This is very important for survival of marine life which lives in ponds in the colder areas. In extremely cold weather the water at the top become colder and colder, until it freezes. While the ice floats on the top, the animals continue to live in the water below, which does not freeze and remains at 4°C . The ice on the top of the pond insulates water below it and it stops the water from losing the heat to air.

11.12 Freezing

You might have observed coconut oil and ghee getting converted from liquid state to solid state during winter season.

- What could be the reason for this change?
- What happens to water kept in a refrigerator?
- How does it get converted from liquid phase to solid phase?

We know that the water that is kept in a refrigerator converts to solid ice. You know that initial temperature of water is more compared to the temperature of ice. It means that during the process of conversion from liquid to solid, the internal energy of the water decreases so that it becomes a solid ice. This process is called *freezing*.

“The process in which a substance in liquid phase changes to solid phase by losing some of its energy is called *freezing*.”

Freezing of water takes place at 0°C temperature and at one atmospheric pressure.

- Are the volumes of water and ice formed with same amount of water equal? Why?

Let us find out.

Activity 13

Take small glass bottle with a tight lid. Fill it with water completely without any gaps and fix the lid tightly in such a way that water does not come out of it. Put the bottle into the deep freezer of a refrigerator for a few hours. Take it out from the fridge and you will observe that the glass bottle breaks.

- Why did the glass bottle break?

We know that the volume of the water poured into the glass bottle is equal to the volume of the bottle. When the water freezes to ice, the bottle is broken. This means that the volume of the ice should be greater than the volume of the water filled in the bottle.

In short, we say that water ‘expands’ (increases in volume) on freezing!

Thus the density of ice is less than that of water and this explains why ice floats on water.



Think and discuss

- Why do we wear cotton clothes in summer?
- Why do we see water droplets on outer surface of a glass containing ice - cold water?
- Why do pigs toil in the mud during hot summer?
- Why do we store water in matkas (earthen pots)?



Key words

Temperature, Heat, Thermal equilibrium, Specific heat, Evaporation, Condensation, Humidity, Dew, Fog, Boiling, Latent heat of vaporization, Melting, Freezing.



What we have learnt

- Heat is a form of energy, in transit, that flows from a body at higher temperature to a body at lower temperature.
- SI unit of heat is Joule. Its CGS unit is Calorie.
1 calorie = 4.186 J.
- When two or more bodies at different temperatures are brought into thermal contact, then net heat lost by the hot bodies is equal to net heat gained by the cold bodies until they attain thermal equilibrium.
- The average kinetic energy of the molecules is directly proportional to the absolute temperature.
- The specific heat of a substance is the amount of heat required to raise the temperature of unit mass of the substance by one unit.

$$S = \frac{Q}{m\Delta t}$$

- The process of escaping of molecules from the surface of a liquid at any temperature is called evaporation and it is a cooling process.
- Condensation is the reverse process of evaporation.
- Boiling is the process in which the liquid phase changes to gaseous phase at a constant temperature and constant pressure.
- The heat energy used to change the state of water from liquid to vapour is called Latent heat of vapourisation.
- The heat energy required to convert 1 gm of solid completely into liquid at a constant temperature is called latent heat of fusion.



Improve your learning



I. Reflections on concepts

1. Why do we get dew on the surface of a cold soft drink bottle kept in open air? (AS₁)
2. Water can evaporate at any temperature Explain with an example? (AS₁)
3. What role does specific heat play in keeping a watermelon cool for a long time after removing it from a fridge on a hot day? (AS₇)
4. Equal amounts of water are kept in a cap and in a dish. Which will evaporate faster? Why? (AS₃)
5. Why specific heat is different for different substances? Explain (AS₁)

II. Application of concepts

1. Using the concept of evaporation explain why dogs pant during hot summer days? (AS₁)
2. If 50g of water at 20°C temperature and 50 g of water 40°C temperature are mixed, what is the final temperature of the mixture of? (AS₁)
3. What do you observe in the surroundings in terms of cooling or heating when water vapour is getting condensed (AS₁)

III. Higher Order Thinking Questions

1. Suppose that 1 L of water is heated for a certain time to rise its temperature for 2°C. If 2L of water is heated for the same time, how much of its temperature would rise? (AS₇)
2. Answer these (AS₁)
 - (a) How much energy is transferred when 1 g. of boiling water at 100°C condenses to water at 100°C?
 - (b) How much energy is transferred when 1 g. of boiling water 100°C cools to water at 0°C?
 - (c) How much energy is released or absorbed when 1 g. of water at 0°C freezes to ice at 0°C?
 - (d) How much energy released or absorbed when 1 g. of steam at 100°C cools to ice at 0°C?



In class 8, we have learnt about sound will be produced by vibrating bodies and also learnt how sound is transmitted through a medium and received by our ears. In this chapter we will study about nature of sound, its production, propagation and characteristics.

Every day we hear sounds from various sources like birds, bells, machines, vehicles, television and Radio etc. Our ears help us to hear the sounds produced at a distance.

- How does sound reach our ears from the source of its production?
- Does it travel by itself or is there any force bringing it to our ears?
- What is sound? Is it a force or an energy?
- Why don't we hear sounds when our ears are closed?

Let us find out.

Activity-1

12.1 Sound is a form of energy

Take a tin can and remove both ends to make a hollow cylinder as shown in

fig.- 1. Take a balloon and stretch it over the can. Wrap a rubber band around the balloon. Take a small piece of mirror and stick it on the balloon. Take a laser light and let it fall on the mirror. After reflection the light spot is seen on the wall as shown in fig.-1. Now shout directly into the open end of the can and observe the dancing light.



Fig-1: Observing vibrations of light

- Why is the light ray dancing, after sound is made in the tin?
- What do you infer from this?
- Can we say that sound is a form of mechanical energy?

Like the stretched rubber sheet in the above activity, sound produced at a

distance travels through air and reaches our ears to produce a sensation of hearing in our ears.



Do you know?

Glimpses of history of sound

From the very early times the question “How sound travels through air”, attracted the attention of philosophers. Pythagoras (around 570 B.C), a Greek scholar and traveller, explained that sound travels in air due to the **to and fro motion** of the air particles, which act upon the ear and produce the sensation of sound. Galileo (1564-1642) and Bacon (1561-1625) agreed with the above theory but it was Newton who first explained the phenomenon of propagation of sound through air.

12.2 Production of sound

Activity-2

Observing the vibration of tuning fork

Take a tuning fork and strike one of its prongs gently with a rubber hammer and bring it near your ear.

- Do you hear any sound?

Touch one of the prongs of the tuning fork with your finger. What do you feel? Share your feeling with your friends.

- Do you see any vibrations in the tuning fork?

To see vibrations, attach a small piece of steel wire to one of its prongs as shown in fig.- 2. While it is vibrating, try to draw a straight line on a piece of smoked glass as quick as possible with it. Keep the end of the wire in such a way that it just touches the glass. A line is formed in the form of wave as shown in fig.- 2. Repeat the experiment when the fork is not vibrating and observe the difference in the line formed.

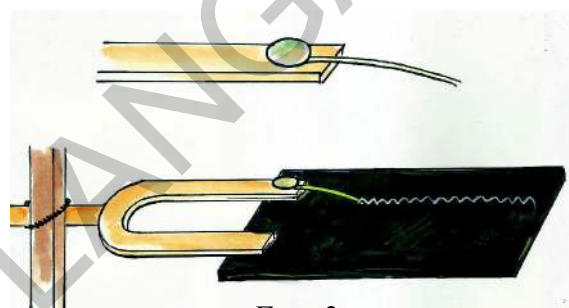

Fig - 2

- What do you conclude from the above activity?
- Can you produce sound without vibration in the body?

In above activity we have produced vibrations in a tuning fork by striking it with a rubber hammer. We observe that a vibrating tuning fork produces sound. Thus sound is produced by vibrating bodies.

- Give some examples of vibrating bodies which produce sound.
- Which part of our body vibrates when we speak?
- Do all vibrating bodies necessarily produce sound?



Do you know?

A tuning fork is an acoustic resonator; it is a steel bar, bent into a U- shape (Prongs), with a handle at the bend. It resonates at a specific constant pitch when set into vibration by striking it with a rubber hammer. The pitch of the tuning fork depends on the length of the prongs. It is mainly used as a standard of pitch to tune other musical instruments.

The device first invented in 1711 by a British musician John Shore.



12.3 How does sound travel?

We know that sound is a form of energy. It travels through air and reaches our ears to give sensation of sound.

- If energy transfer takes place during sound propagation, then in which form, does it travel through air?

There may be two possible ways by which transfer of energy from the source of sound to our ears takes places. One is that the source of sound produces disturbances (waves) in air and they strike our ears. The other explanation is that some particles are shot off from the source of sound and they reach our ears.

If the second explanation is correct, vibrating body would gradually lose its weight as particles are continuously shot off from it. This certainly never happens, because it would lead to vanishing of the object. Thus we can conclude that ‘sound travels through disturbances in the form of waves’, can be taken as a correct explanation.

- If sound travels in the form of a wave then what is the pattern?

12.3.1 Propagation of Sound

We know that sound is produced by vibrating objects. The matter or the substance through which sound is transmitted is called the medium.

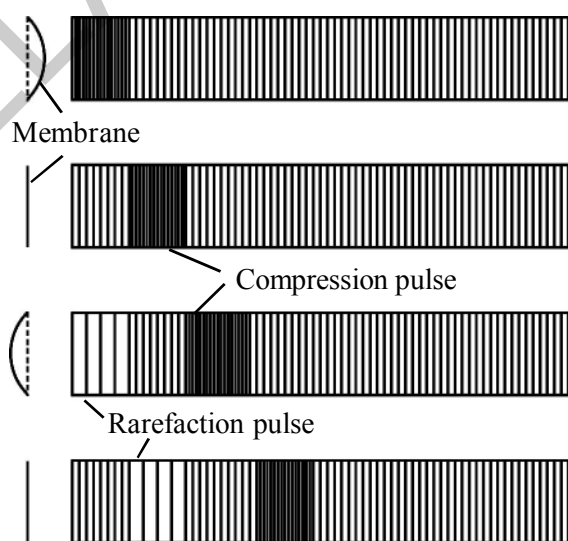

Fig-3

When a source of sound vibrates it creates a disturbance in the medium near it. This means that the condition of the medium near the source becomes different from its normal condition. The disturbance could be in the form of compression of the medium close to the source. This

disturbance then travels in the medium. Let us see how it travels.

Consider a vibrating membrane of musical instrument like a drum or tabla. As it moves back and forth, it produces a sound. Fig.- 3 shows the membrane at different instants and the condition of the air near it at those instants.

As the membrane moves forward (towards the right in Figure), it pushes the particles of air in the layer in front of it. So, the particles of air in the layer get closer to each other. Hence the density of air increases locally and this layer of air pushes and compresses the layer next to it, which then compresses the next layer, and so on. In this way the disturbance moves forward. We call this type of disturbance as compression pulse. The particles of the medium do not travel with the compression pulse, they only oscillate about a mean position. It is the disturbance which travels in the forward direction.

What happens when the membrane moves back to the left in fig.- 3? It drags back the layer of air near it, decreasing the density of air there. The particles of air in the next layer on the right move and fill this less dense area. As a result, its own density reduces. In the same way, the density of air in successive layers on the right decrease one after the other. We say that a rarefaction pulse moves to the right.

As the membrane moves back and forth repeatedly, compression and rarefaction pulses are produced, one after the other. These two types of pulses travel one behind the other, carrying the disturbance with it. This is how sound travels in air.



Think and Discuss

Do compressions and rarefactions in sound wave travel in same directions or in opposite directions ? Explain.

12.4 Types of waves

Activity-3

Demonstrating types of wave propagation

R C R C R C R C R C R C R C R C



Fig-4 Compressions(C) and rarefactions (R) in a slinky

1. Take a slinky, it is a spring – shaped toy which can be extended or compressed very easily. It is very flexible and can be put into many shapes easily. You can send continuous waves on a slinky. Lay it down on a table or the floor as shown in the fig.- 4 and ask a friend to hold one end. Pull the other end to stretch the slinky, and then move it to and fro along its length.

You will see alternate compressions and rarefactions of the coil. This is similar to the pattern of varying density produced in a medium when sound passes through it.



Fig-5: Transverse waves in a slinky

2. Hang a slinky from a fixed support. Hold it gently at the lower end and quickly move your hand sideways and back. What do you observe? This will cause a hump on the slinky near the lower end.

This hump travels upwards on the slinky as shown in fig.- 5. What is travelling upwards? The part of the slinky that was at the bottom in the beginning is still at the bottom. Similarly no other part of the slinky has moved up. Only the disturbance has moved up. Hence we may say that a wave has travelled up through the slinky.

We have discussed two examples of wave propagation in a slinky. In the first case the vibrations are along the direction of wave motion and in the second case the vibrations are perpendicular to the direction of wave motion.

If the particles of the medium vibrate along the direction of wave, the wave is called a longitudinal wave.

If the particles of the medium vibrate perpendicular to the direction of wave, then the wave is called a transverse wave.

Longitudinal wave involves change in the density of the medium, whereas transverse wave involves change in the 'shape' of the medium.

- What do you say about sound waves in air by the above activity?
- Are they longitudinal or transverse?

12.4.1 Sound waves are longitudinal

As we have seen, when a sound wave passes through air, the layers in the medium are alternately pushed and pulled. Thus the particles of the medium move to and fro along the direction of propagation. Therefore sound waves in air are longitudinal.

12.5 Characteristics of the sound wave

Four quantities play an important role in describing the nature of a wave. These quantities are its wave length, amplitude, frequency and wave speed. They are called characteristics of the wave. Let us learn about these characteristics in the context of the sound wave.

Let us consider a sound wave produced by a source such as a tuning fork. Fig.- 6 shows the variation in the density of air near the source at a particular time and the variation in the density of air with position is also shown by a graph in Fig.- 6.

Since the pressure of air is proportional to density at a given temperature, the plot of density versus position will also have the same shape.

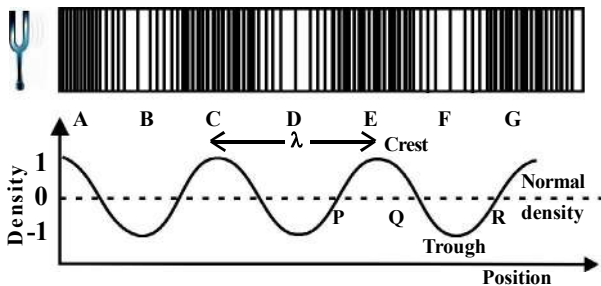

Fig-6

It can be seen from the graph that in portions like PQ, the density is more than the normal density, represents a compression. In portions like QR, the density is less than the normal, represents a rarefaction.

Thus the compressions are the regions where density as well as pressure is high. Rarefactions are the regions where the density as well as pressure is low. In above density vs. position graph, the peak of the graph is called crest and valley of the graph is called trough.

12.5.1. Wave length

At any given instant, the density of air is different at different places along the direction in which sound is moving. For a source like a tuning fork, the distance between the consecutive position of maximum density (compressions) (like C and E in the above fig.- 6) or minimum density (rarefactions) like B and D as shown in fig.- 6 remain the same. So these values get repeated after a fixed distance. This distance is called the wave length of the wave. It is denoted by the Greek letter λ (read as 'lambda'). We can define wavelength as follows.

The distance between two consecutive compressions or two consecutive rarefactions is called the wave length of a sound wave. In density-position graph, the distance between two successive crests (or) troughs is called wavelength.

Being a length, wavelength is measured in metres. SI unit of wave length is metres (m).

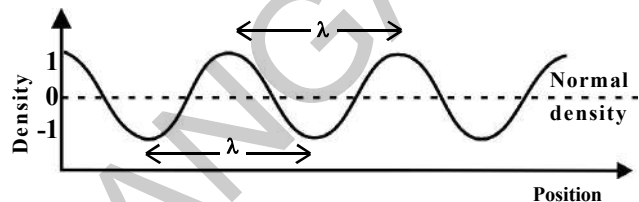

Fig-7

12.5.2. Amplitude

The amplitude of a sound wave in air can be described in terms of the density of air or pressure of air or the displacement of the layers of air. You know that when sound travels in air, the layers of air move to and fro, causing compressions and rarefactions. As a result, the density and pressure of air at a place varies. Its value increases from the normal to reach a maximum and then reduces to a minimum.

The amplitude of density of medium is the maximum variation in the density when sound wave passes through it. Similarly we can define amplitude of pressure and displacement of the particle of a medium when sound travels through it.

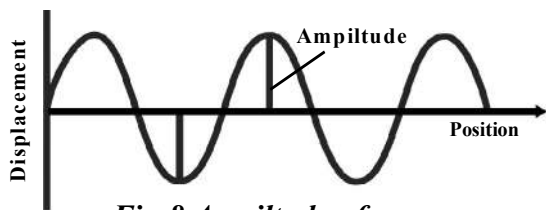

Fig-8 Amplitude of a wave

Thus the maximum disturbance of particles in the medium on either side of mean position is called amplitude of wave. It is usually represented by a letter A. The units of amplitude depend on which terms the amplitude is being described. Because if sound wave is moving through air we describe amplitude in terms of density and pressure. If sound wave is moving in solids, we describe amplitude in terms of displacement of particles from their mean positions.

Terms of describing amplitude	Units of amplitude
Density	kg/m ³
Pressure	pascal
Displacement	metre.

12.5.3 Time period and frequency

We know that when sound is propagating through a medium the density of medium oscillates between a maximum value and a minimum value.

“The time taken to complete one oscillation of the density of the medium is called the time period of the sound wave”. It is represented by the symbol (T). Its SI unit is second (s).

Frequency is a quantity that is closely related to time period. We can define that the frequency of sound wave as follows.

“The number of oscillations of the density of the medium at a place per unit time is called the frequency of the sound wave”.

We usually use the Greek letter ν (read as ‘nu’) to denote frequency.

Relation between frequency and time period

Let us find the relationship between frequency and time period.

Let the time taken for ν oscillations = 1s

The time taken for one oscillation = $(1/\nu)$ s

But the time taken for one oscillation is called the time period (T) and the number of oscillations per second is called the frequency (ν).

Hence Frequency and time period are related as $T = 1/\nu$ or $\nu = 1/T$

The SI unit of frequency is hertz (Hz). It is named after Heinrich Rudolph Hertz.



Do you know?

Heinrich Rudolf Hertz was born on 22 February 1857 in Hamburg, Germany and educated at the University of Berlin. He was the first to conclusively prove the existence of electromagnetic waves. He laid the foundation for future development of radio, telephone, telegraph and even television. He also discovered the photoelectric effect which was later explained by Albert Einstein. The SI unit of frequency was named hertz in his honour.



Larger units of frequency

Kilo hertz (KHz)	10^3 Hz
Mega hertz (MHz)	10^6 Hz
Giga hertz (GHz)	10^9 Hz
Tera hertz (THz)	10^{12} Hz

Example-1

Find the time period of the wave whose frequency is 500Hz?

Solution

$$\begin{aligned} \text{from } T = 1/\nu &= 1/500 \text{ s} \\ &= 0.002 \text{ s} \end{aligned}$$



Think and discuss

- Does the frequency of sound waves depend on the medium in which it travels? How?
- The frequency of source of sound is 10Hz. How many times does it vibrate in one minute?
- Gently strike a hanging bell (temple bell) and try to listen to the sound produced by it with a stethoscope keeping it both at bottom portion and top portion of the bell. Is the pitch and loudness of the sound same at the two portions? Why?

12.6 Speed of Sound wave

The distance by which a point on the wave, such as a compression or rarefaction, travels in unit time is called speed of sound wave.

Let the distance travelled by a wave in T seconds = λ metres.

The distance travelled by a wave in

$$1 \text{ second} = \frac{\lambda}{T} \text{ metres.}$$

Thus by definition, speed of sound wave

$$v = \frac{\lambda}{T} \text{ ————— (1)}$$

We know that frequency $\nu = \frac{1}{T}$ —(2)

From equation (1) & (2) we get $v = \nu \lambda$
Speed of a sound wave } = frequency x wave length.

The speed of a sound wave depends on the properties such as the temperature and nature of the medium in which it is travelling. But the speed of sound remains almost the same for all frequencies in a given medium under the same physical conditions.

In common, speed of sound refers to the speed of sound waves in air. However speed of sound varies from substance to substance. Sound travels faster in liquids and nonporous solids than it does in air. It travels about 4.3 times faster in water (1484 m/s) and nearly 15 times as fast in iron (5120 m/s) than in air at 20° C. In dry air at 20° C the speed of sound is 343.2 m/s. this is 1236 km/hr or about 1km in 3s.



Think and discuss

- During a thunderstorm if you notice a 3 second delay between the flash of lightning and sound of thunder. What is the approximate distance of thunderstorm from you.

Example-2

1. In a certain gas, a source produces 40,000 compression and 40,000 rarefaction pulses in 1 sec. When the second compression pulse is produced; the first is 1cm away from the source. Calculate the wave speed.

Solution

We know frequency is equal to number of compression or rarefaction pulses travelled per second, hence frequency (ν) = 40,000 Hz

Wave length (λ) = distance between two consecutive compression or rarefaction pulses.

$$\lambda = 1 \text{ cm}$$

$$\text{From } v = \nu \lambda = 40,000 \text{ Hz} \times 1 \text{ cm} = 40,000 \text{ cm/s} = 400 \text{ m/s}$$



Do you know?

Sonic boom

When a body moves with a speed which is greater than the speed of sound in air, it is said to be travelling at supersonic speed. Jet fighters, bullets etc., often travel at supersonic speeds.

When a sound producing source moves with a speed higher than that of sound, it produces shock waves in air. These waves carry a large amount of energy. They produce a very sharp and loud sound called the sonic boom.

The sonic boom produced by supersonic aircraft is accompanied by waves that have enough energy to shatter glass and even damage buildings.

Characteristics of a musical sound

In the previous class, we learnt that all sounds can be roughly classified as musical

sounds and noises. The sounds which produce pleasing effect on the ear are called musical sounds while the sounds which produce unpleasant effect are called noises.

There are three characteristics by which we can distinguish a musical note from other.

They are 1. Pitch 2. Loudness
3. Quality

12.6.1. Pitch

- Sound of mosquito is shrill while sound of lion is growl.
- Female voice is shriller than male voice.

From the above examples, what property of sound differentiates them?

Actually pitch of sound is the sensation conveyed to our brain by the sound waves falling on our ears which depends directly on the frequency of the incident sound waves. The greater the frequency of a musical note, higher is the pitch.

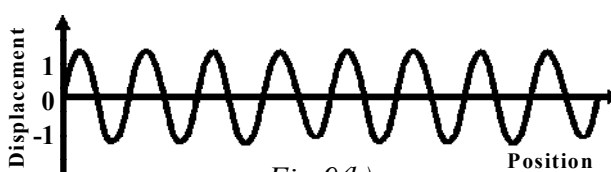
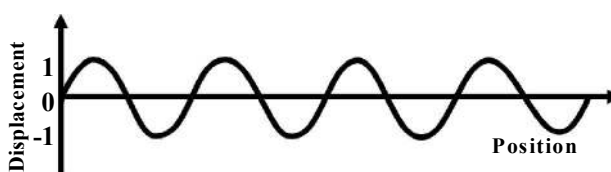

In musical terms, the pitch of the note determines the position of the note on the musical scale which is denoted as

Note:	C (sa)	D (re)	E (ga)	F (ma)	G (pa)	A (dha)	B (ni)	C ¹ (sa) ¹
Frequency (Hz)	256	288	320	341.3	384	426.7	480	512

The tuning fork set is prepared based on the above frequencies.

12.6.2. Loudness

If we strike a school bell lightly, we hear a soft sound. If we hit the same bell hard we hear a loud sound. Can you guess the reasons for this change? The reason for this change in intensity of sound is due to the another characteristic of sound called loudness.

Loudness of sound is defined as the degree of the sensation produced on the ear.

The loudness or softness of a sound is determined basically by its amplitude. The amplitude of the sound wave depends upon the 'force' with which the objects are made to vibrate.

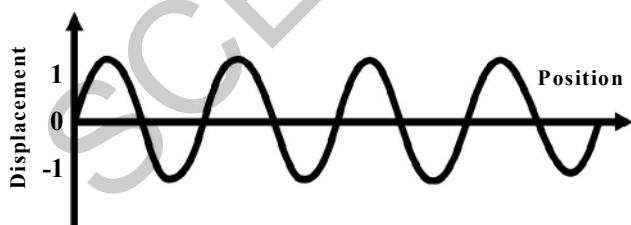

Fig-10(a) Louder sound

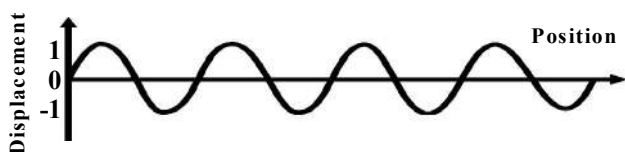

Fig-10(b) Soft Sound

In the above figures 10(a) and 10(b) the variation of wave disturbance with time is shown as a graph for two sounds with different amplitudes.

The amplitude of the sound wave in fig.-10(a) is greater than the amplitude of sound wave in fig.-10(b). So the graph in fig.-10(a) represents a louder sound and the graph in fig.-10(b) represents a soft sound.

The loudness of the sound is measured in decibels (dB). It signifies the sound pressure level. Human ears pickup sounds from 10 dB to 180 dB. The loudness of sound is considered normal, if it is between 50 dB to 60dB.

A normal human being can tolerate loudness of 80 dB. The sound above 80 dB is painful and causes various health problems. The decibel level of a jet engine taking off is 120 dB.

Therefore people working near the airbase need to protect their ears by using ear plugs. Otherwise it may lead to hearing loss. Listening to very loud music through earphones of MP3 player or mobile phones also leads to hearing loss because loudness of sound means high energy is delivered to

our ears. Hence we should be very careful when listening to music through ear phones.

12.6.3. Quality

You might have noticed different sounds produced by different instruments such as violin, piano, flute, etc. To distinguish between two sounds, we need to learn about the quality of sound.

The quality of sound is the characteristic which enables us to distinguish between musical notes emitted by different musical instruments or voices even though they have the same pitch and loudness. It is because different wave forms are produced by different musical instruments. Hence the quality of a note depends on its wave form.

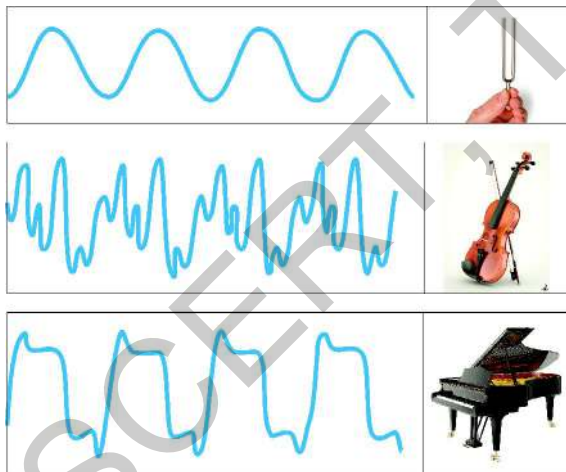

Fig-11

Fig.-11 shows graphical representation of sound waves produced by a tuning fork, a violin and a piano playing the same note (fundamental frequency = 440Hz) with equal loudness (amplitude).



Think and discuss

- Two girls are playing on identical stringed instruments. The strings of the both instruments are adjusted to give notes of same pitch. Will the quality of two notes be same? Justify your answer.
- What change would you expect in the characteristic of a musical sound when we increase its frequency at one instance and amplitude at another instance?

12.7 Reflection of sound

Does sound get reflected at the surface of a solid? Let us find out?

Activity-4

Listening to reflected sound

Take two long, identical tubes and place them on a table near a wall. Ask your friend to speak softly into one tube while you use the other tube to listen. Adjust the tube until you hear the best sound. You will find that you hear your friend's voice best when the tubes make equal angles with a normal to the wall as shown in fig.-12. Why?

Reflection of sound follows the same laws as the reflection of light. When sound is reflected. i.e., the directions in which the sound is incident and reflected make equal angles with the normal to the reflecting surface.

- What happens if you lift your tube slightly above the table?

- Are able to listen to the sound? If not why?

You will not be able to hear your friend's voice clearly. Think about the planes of the tube carrying incident sound and reflected sound. What will happen to these planes if we lift one of the pipes? If you lift one of the pipes then the pipe carrying incident sound and the pipe carrying reflected sound will not be in the same plane. Hence we cannot hear a clear sound.

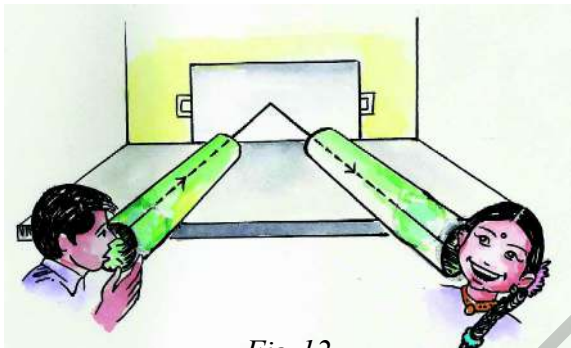

Fig-12

Repeat the experiment by placing flat objects of different materials (steel and plastic trays, a card board, a tray draped with cloth, etc) against the wall and observe changes in sounds.

- Do hard surfaces reflect sound better than soft ones?

As you have seen in the second part of the activity, the reflection of sound is dependent on the reflecting surface. Generally, hard surfaces reflect sound better than soft surfaces. But unlike light, which is reflected well only from highly polished surfaces, sound reflects quite well from rough surfaces as well. For example, an un-plastered brick wall will reflect sound quite well.



Think and discuss

- What could be the reason for better reflection of sound by rough surfaces than polished surfaces?

12.7.1 Echo

If we shout or clap standing at a suitable distance from a reflecting object such as a tall building or a mountain, we will hear the same sound again a little later. This sound which we hear is called an echo. The sensation of sound persists in our brain for about 0.1s. This is called persistence of sound. To hear a distinct echo, the time interval between the original sound and the reflected sound must be at least 0.1s.

This means that if a sound produced by a source is reflected in less than 0.1 sec., the echo would not be heard. For sound to reflect after 0.1 sec., what should be the minimum distance between the source and the obstacle? Let us now derive a formula for finding out speed of sound, to hear an echo.

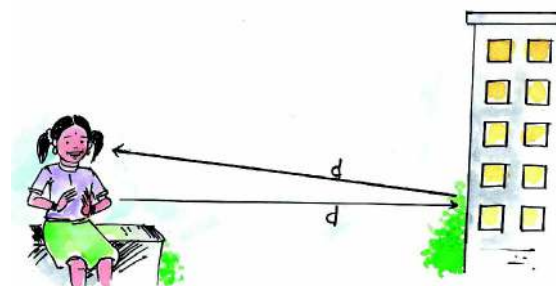

Fig-13

Let the distance travelled by sound from source to obstacle = d

Then distance travelled by sound from obstacle to source = d

Thus, total distance travelled by sound wave = $2d$

Let echo time be 't' sec

$$\text{Speed of sound} = \frac{\text{total distance travelled}}{\text{echo time}} = \frac{2d}{t}$$



Do you know?

The roaring of thunder is due to the successive reflections of the sound from a number of reflection surfaces, such as the clouds and the land.



Think and discuss

- Why is an echo weaker than the original sound?

Example-3

An echo is heard after 0.8s, when a boy fires a cracker, 132m away from a tall building. Calculate the speed of sound?

Solution

$$\text{Echo time (t)} = 0.8\text{s}$$

Total distance travelled by sound wave

$$2d = 2 \times 132 \text{ m} = 264\text{m}$$

From, speed of sound $V = \frac{2d}{t}$

$$V = \frac{264}{0.8} = 330 \text{ m/s}$$

Reverberation

A reverberation is perceived when the reflected sound wave reaches your ear in less than 0.1s after the original sound wave. Since the original sound and reflected sound waves tend to combine, we get to hear one, prolonged sound wave.

In an auditorium or big hall excessive reverberation is highly undesirable. To reduce reverberation, the roof and walls of the auditorium are generally covered with sound – absorbent materials like compressed fibre board, rough plaster or draperies. The seat materials are also selected on the basis of their sound absorbing properties.



Think and discuss

- In a closed box if you say hello, the sound heard will be Helloooooo..... What does it mean?

Relation between Echo and Reverberation

Reverberation is quite different from an echo. A reflected sound, arriving at the position of listener more than 0.1s after the direct sound is called an echo. A reflection of sound, arriving at the listener in less than 0.1s after the direct sound is called reverberation.

12.8 Uses of multiple reflection of sound

1. A megaphone and a horn

Megaphones, horns, musical instruments such as trumpets, shehanai and loud speakers are all designed to send sound in a particular direction without spreading it in all directions as shown in fig.-14.

In these instruments, a tube followed by a conical opening reflects sound successively to guide most of the sound waves from the source in the forward direction towards the audience.

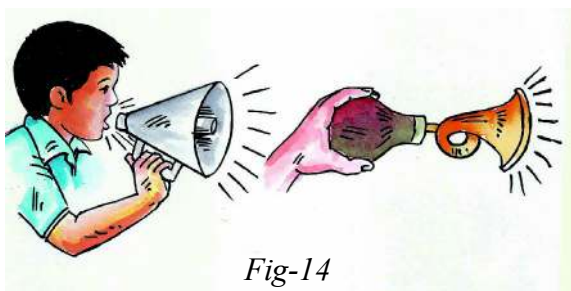

Fig-14



Think and discuss

- What is the advantage of having conical openings in Horns, megaphones etc ?

2. Stethoscope

Stethoscope is a medical instrument used for listening the sounds produced within the body, mainly in the heart or lungs. In stethoscopes the sound of the patient's heartbeat reaches the doctor's ears by multiple reflection and amplifying the sound as shown in fig.- 15.



Fig-15

3. Designing of concert halls and cinema halls

Generally the ceilings of concert halls, conference halls and cinema halls are

designed such that sound after reflection reaches all corners of the hall, as shown in fig.- 16. In some halls a curved ceiling is arranged in such a way that the sound after reflecting from the ceiling spreads evenly across the hall.

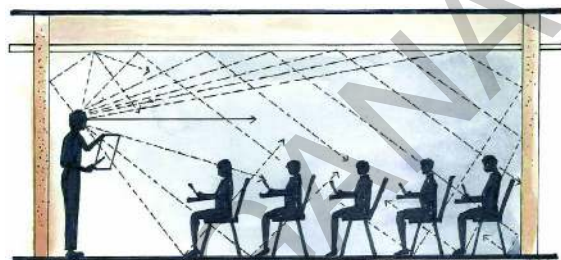

Fig-16



Think and discuss

- Why do we put cushions on the chairs, carpet on the floor, straw materials on the walls in cinema halls?

12.8.1 Range of hearing

The human ears are able to hear sound in a frequency range of about 20 Hz to 20,000 Hz. The range of audibility is 20 Hz- 20 KHz. We cannot hear sounds of frequencies less than 20 Hz or more than 20 KHz. These limits vary from person to person and with age. Children can hear sounds of somewhat higher frequencies, say up to 30 KHz. With age, our ability to hear high-frequency sound diminishes. For the elders, the upper limit often falls to 10-12 KHz. However, we take 20-20,000 Hz as the audible range for an average person.

Even in the audible range, the human ears are not equally sensitive to all frequencies. It is the most sensitive to frequencies around 2,000-3,000 Hz, where it can hear even a very low-intensity sound.

Sound of frequency less than 20 Hz is known as infrasonic sound or infrasound. Sound of frequency greater than 20 KHz is known as ultrasonic sound or ultrasound.



Do you know?

Different animals have different ranges of audible frequencies. A dog can hear sounds of frequencies up to about 50 KHz and a bat, up to about 100 KHz. Dolphins can hear sounds of even higher frequencies. These animals can also produce ultrasonic waves and communicate using them. Bats use ultrasonic waves to navigate, as we shall see a little later. Animals such as elephants and whales produce sounds of frequencies less than 20 Hz. Scientists have found that elephants grieve over their dead by producing infrasonic sounds. Some fishes can hear sounds, of frequencies as low as 1-25 Hz. Rhinoceroses communicate using infrasonic sounds of frequency around 5 Hz.

12.9 Applications of ultrasound

Ultrasounds are high frequency sound waves. They are able to travel along a well defined path in gaseous and liquid media. Ultrasound is used extensively in industries and for medical purposes.

12.9.1 Industrial applications of ultrasonic waves

1. Drilling holes or making cuts of desired shape

Holes can also be drilled using ultrasonic vibrations produced in a metallic rod, called a horn. This acts like a hammer, hammering the plate about a hundred thousand times per second.

The shape of the hole is the same as that of the tip of the horn. Ultrasonic cutting and drilling are very effective for fragile materials like glass, for which ordinary methods might not succeed.

2. Ultrasonic cleaning

We normally clean dirty clothes, plates or other large objects by dipping them in a detergent solution and then rubbing and washing. Parts located in hard-to-reach places, cannot be easily cleaned by this method.

Ultrasonics help in cleaning such objects which are placed in a cleaning solution and ultrasonic waves are sent into the solution. This causes high-frequency vibrations in the solution. These vibrations knock off all dirt and grease particles from the objects, which are then removed using ordinary water.

3. Ultrasonic detection of defects in metals

Metallic components are used in buildings, bridges, machines, scientific equipment, and so on.

If there are cracks or holes inside the metal used, the strength of the structure or component is reduced and it can fail. Such defects are not visible from the outside. Ultrasonic waves can be used to detect such defects.

12.10 Medical applications of ultrasound

1. Imaging of organs

Ultrasonic waves have given doctors powerful and safe tools for imaging human organs. Echocardiography (ECG) is a technique in which ultrasonic waves, reflected from various parts of the heart, form an image of the heart.

Ultrasonography (USG) is routinely used to show doctors, the images of a patient's organs such as the liver, gall bladder, uterus, etc. It helps doctors to detect abnormalities such as stones in the gall bladder, tumors, etc.

It is also used to monitor the growth of a foetus inside the mother's womb.

Ultrasonography is safer than older X-ray imaging technique. Repeated X-rays can harm tissues, especially those of a foetus.



Fig-17: Image of Ultrasound scanning

2. Surgical use of ultrasound

The ability of ultrasonic waves to cause molecules of materials to vibrate vigorously and thus cause certain materials

to break into tiny pieces (emulsify) is employed in ultrasound surgery. Cataract removal is a very common example.

Ultrasound is also employed to break small stones that form in the kidneys into fine grains. These grains get flushed out with urine. This method has eliminated the need to perform surgery.



Think and discuss

- What is the benefit of using ultrasound over light waves in the above applications?

12.11 SONAR

Do you know how we can measure the depth of the sea? Let us find out.

SONAR stands for *Sound Navigation And Ranging*. This is a method for detecting and finding the distance of objects under water by means of reflected ultrasonic waves. The device used in this method is also called SONAR.

- How does a SONAR system work?

SONAR system consists of a transmitter and a receiver which are installed in the "Observation Centre" on board of a ship. From the observation centre on board a ship, ultrasonic waves of high frequencies, say 100 KHz, are sent in all directions under the water through transmitter. These waves travel in straight lines till they hit an object such as a submarine, a sunken ship, a school of fish, etc.

The waves are then reflected, and are received back by the receiver at the observation centre. The direction from which a reflected wave comes to the observation centre tells the direction in which the object is located. From the time between sending the ultrasonic wave and receiving its echo, and the speed of sound in sea water, the distance of the object from the observation centre is calculated. Reflections from various angles can be utilized to determine the shape and size of the object.

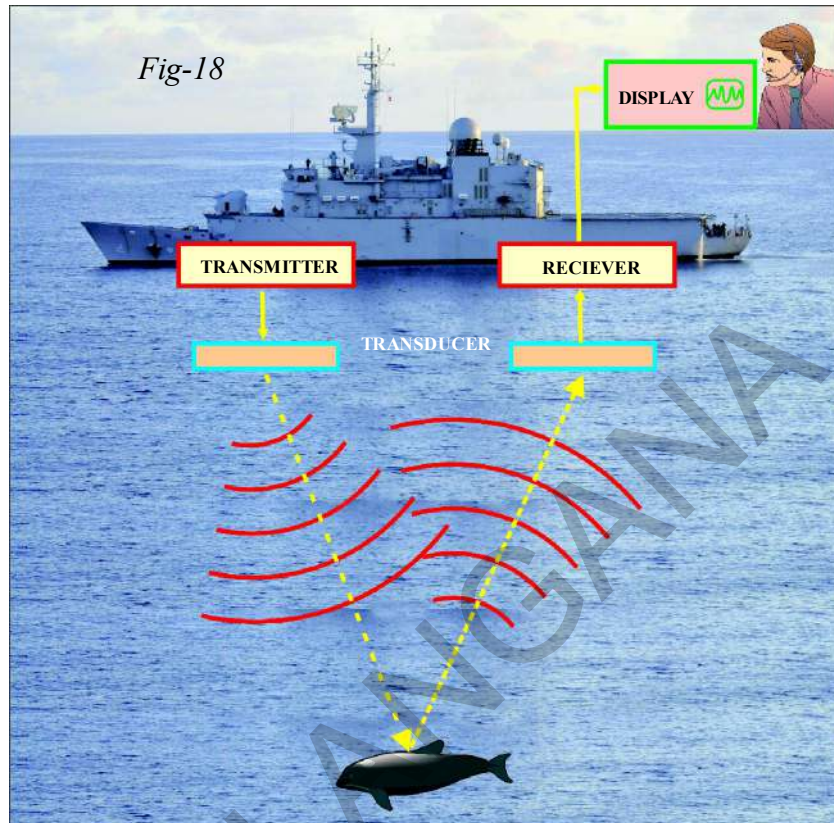

Let d be the distance between the sonar and an underwater object, t be time between sending an ultrasonic wave and receiving its echo from the object and u is the speed of sound in water.

The total distance covered by the wave from the sonar to the object and back is $2d$.

Using $s = ut$,

$$\text{Or } 2d = ut$$

$$d = \frac{ut}{2}$$

This method of finding distances is also called echo ranging. Marine geologists use this method to determine the depth of the sea and to locate underwater hills and valleys. In the same way Bats also produce ultrasonic sounds and identify the obstacles in their path to change their way.

Example 4

A research team sends a sonar signal to confirm the depth of a sea. They heard an echo after 6s. Find the depth of the sea. If the speed of sound in sea water is 1500 m/s?

Solution

Let the depth of the sea = d m

Then Total distance

travelled by sonar signal (s) = $2d$

Speed of sound in sea water (u)

$$= 1500 \text{ m/s}$$

Total time taken (t) = 6s

From, $s = ut$,

$$2d = 1500 \text{ m/s} \times 6\text{s}$$

$$d = 9000/2 \text{ m} = 4.5 \text{ km}$$



Key words

Mechanical energy, tuning fork, longitudinal wave, transverse wave, compression, rarefaction, crest, trough, density of medium, pressure, wavelength, amplitude, frequency, pitch, loudness, quality of sound, echo, reverberation, infrasonic, audible range, ultrasonic and SONAR.



What we have learnt

- Sound is a form of mechanical energy which produces sensation of hearing.
- A tuning fork is an acoustic resonator, which resonates at constant pitch when set into vibration.
- If the particles of the medium move to and fro along the direction of propagation of the wave, the waves are called longitudinal waves.
- If the particles of the medium vibrate perpendicular to the direction of propagating wave, the waves are called transverse waves.
- Sound waves are longitudinal.
- The region of high density of particles in the medium during propagation of sound is called compression and low density regions are called rarefaction.
- The distance between two consecutive compressions or rarefactions is called wavelength.
- The maximum variation in density or pressure from the mean value is called amplitude or the maximum disturbance of particles of a medium from their mean position is called amplitude.
- The time taken to complete one oscillation of density in the medium is called time period of sound wave.
- The number of oscillations of the density of the medium at a place per unit time is called frequency.
- The distance by which a point of on the wave, such as a compression or rarefaction travels per unit time is called speed of sound.
- Loudness of sound is defined as the degree of sensation produced in the ear.
- The quality of sound is the characteristic which enables us to distinguish between musical notes emitted by different musical instruments.
- A reflection of sound, arriving at the listener in more than 0.1s after direct sound is called an echo.
- A reflection of sound, arriving at the listener in less than 0.1s after direct sound is called reverberation.
- Sound of frequency between 20Hz – 20KHz is called sonic or audible limit.

- Sound of frequency less than 20Hz is known as infrasonic sounds.
- Sound of frequency higher than 20KHz is known as ultrasonic sounds.
- SONAR stands for Sound Navigation and Ranging.



Improve your learning



I. Reflections on concepts

1. Explain the following terms
a) amplitude b) wavelength c) frequency (AS₁)
2. Write the relation between wavelength, frequency and speed of sound (AS₁)
3. Which has larger frequency – infrasonic sound or ultrasonic sound? (AS₂)
4. Why is soft furnishing avoided in concert halls? (AS₇)

II. Application of concepts

1. Does the sound follow same laws of reflection as light does? (AS₁)
2. Two sources A and B vibrate with the same amplitude. They produce sounds of frequencies 1kHz and 30kHz respectively. Which of the two waves will have larger power? (AS₁)
3. With the help of a diagram describe how compression and rarefaction pulses are produced in air near a source of sound. (AS₅)
4. How are multiple reflections of sound helpful to doctors and engineers? (AS₇)

III. Higher Order Thinking Questions

1. Explain the working and applications of SONAR. (AS₁)
2. How do echoes in a normal room affect the quality of the sounds that we hear? (AS₇)



Multiple choice questions

1. When can you say that the sound is propagating through a medium []
a) If the medium is travelling b) The particles of a medium are travelling
c) When the source of sound is travelling d) When the disturbance is travelling.
2. The unit for the number of waves produced in a second are []
a) hertz b) joule c) meter d) pascal

3. The sounds of frequency less than 20 Hz are known as []
a) Audible range b) Ultra sounds c) Infra sounds d) Sonic boom
4. The sound limit between the frequency of 20Hz – 20000Hz is called as []
a) Audible range b) Ultra sound range c) Infra sound range d) Sonic boom



Suggested Experiments

1. Conduct an experiment to listen the reflected sound and write a report.



Suggested Projects

1. Collect the information about the animals which communicate through Infrasonics or ultrasonics. Collect their pictures and write a report on their communication technique.
2. “We know that the sound is a form of energy. So, the large amount of energy produced due to the sound pollution in cosmopolitan cities can be used to our day to day needs of energy. It also helps us to protect biodiversity in urban areas”. Do you agree with this statement? Collect information on this and write a report.

ACADEMIC STANDARDS

ACADEMIC STANDARDS

S.No.	Academic Standard	Explanation
1.	Conceptual understanding	Children are able to explain, cite examples, give reasons, and give comparison and differences, explain the process of given concepts in the textbook. Children are able to develop their own brain mappings.
2.	Asking questions and making hypothesis	Children are able to ask questions to understand concepts, to clarify doubts about the concepts and to participate in discussions. They are able to guess the results of an issue with proper reasoning, able to predict the results of experiments.
3.	Experimentation and field investigation.	Children are able to do the experiments given in the text book and developed on their own. Able to arrange the apparatus, record the observational findings, suggest alternative apparatus, takes necessary precautions while doing the experiments, able to do alternate experiments by changing variables. They are able to participate in field investigation and prepare reports.
4.	Information skills and Projects	Children are able to collect information related to the concepts given in the text book by using various methods (interviews, checklist questionnaire) analyse the information and interpret it. Able to conduct project works.
5.	Communication through drawing, model making	Children are able to communicate their conceptual understanding by the way of drawing pictures labelling the parts of the diagram by drawing graphs, flow charts and making models.
6.	Appreciation and aesthetic sense, values	Children are able to appreciate the nature and efforts of scientists and human beings in the development of science and have aesthetic sense towards nature. They are also able to follow constitutional values.
7.	Application to daily life, concern to bio diversity.	Children are able to apply the knowledge of scientific concept they learned, to solve the problem faced in daily life situations. Recognise the importance of biodiversity and takes measures to protect the biodiversity.

LEARNING OUTCOMES

The learner...

- ◆ Differentiates material, objects, phenomena and processes based on properties or characteristics.
Eg: (i) Mixtures and compounds, (ii) Speed and velocity, (iii) Weight and mass.
- ◆ Classifies material, objects, phenomena and process based on properties or characteristics.
Eg: (i) Solids, liquids and gases, (ii) Mixtures, compounds and colloids.
- ◆ Plans and conducts simple investigations and experiments to arrive at and verify the facts, principles, phenomena or to seek answers to queries on their own. Also Concludes and Communicates the findings
Eg: (i) Refractive index of glass slab, (ii) Identifies the gases evolved in the reactions.
(iii) writing reports.
- ◆ Relates processes and phenomena with causes and effects.
Eg: (i) Brilliance of diamond, formation of mirages, (ii) Tindal effect.
- ◆ Explains processes and phenomena.
Eg: (i) Refraction of light, (ii) Corrosion.
- ◆ Calculates, analyses using the data given .
Eg: (i) Problem solving based on equations of motion and Newton's laws.
(ii) Calculate weight percentage.
- ◆ Draws labelled diagrams, flow charts, concept maps, graphs.
Eg: (i) Diagram of heating CaCO_3 and evolution of CO_2 gas,
- ◆ Applies learning to hypothetical situations.
Eg: (i) What happens if the rusting of iron articles is not prevented?,
- ◆ Use scientific conventions, symbols and equations to represent various qualities, elements and units.
Eg: (i) Chemical equation for different types of reactions,
(ii) Units for the quantities like, speed, velocity, acceleration and density.
- ◆ Measures physical quantities using appropriate apparatus, instruments and devices.
Eg: (i) Thermometer, (ii) Measuring Jar, (iii) Stop clock, (iv) Weighing machine.
- ◆ Applies Scientific concepts in daily life and solving problems.
Eg: (i) Application of Newton's laws, (ii) Application of refraction of light.
- ◆ Derives formulae, equations and laws.
Eg: (i) Newton's laws, (ii) Chemical equations, formulas.
- ◆ Describes Scientific discoveries and inventions.
Eg: (i) Theories on atomic structure.
- ◆ Designs models using eco-friendly resources.
Eg: (i) Calorie meter, (ii) Lacto meter.
- ◆ Exhibits values of honesty, objectivity, rational thinking, freedom from myths, superstitious beliefs while taking decisions, respect for life etc.



Dear teachers...

New Science Text Books are prepared in such a way that they develop children's observation power and research enthusiasm. It is a primary duty of teachers to devise teaching- learning processes which arouse children's natural interest of learning things. The official documents of National & State Curriculum Frameworks and Right to Education Act are aspiring to bring grass root changes in science teaching. These textbooks are adopted in accordance with such an aspiration. Hence, science teachers need to adapt to the new approach in their teaching. In view of this, let us observe certain **Dos** and **Don'ts**:

- Read the whole text book and analyze each and every concept in it indepth.
- Develop/Plan activities for children which help them to understand concepts presented in text.
- Textual concepts are presented in two ways: one as the classroom teaching and the other as the laboratory performance.
- Lab activities are part and parcel of a lesson. So, teachers must make the children conduct all such activities during the lesson itself, but not separately.
- 'Ask your teacher, collect information from library or internet' - such items must also be considered as compulsory.
- In the text some special activities as boxed items- 'think and discuss, let us do, conduct interview, prepare report, display in wall magazine, participate in Theatre Day, do field observation, organize special days' are presented. To perform all of them is compulsory.
- Children have to be instructed to follow scientific steps while performing lab activities and relevant reports can be prepared and displayed.
- If any concept from any other subject got into this text, the concerned subject teacher has to be invited into the classroom to elucidate it.
- Collect information of relevant website addresses and pass on to students so that they can utilize internet services for learning science. Let there be science magazines and science books in the school library.
- Motivate every student to go through each lesson before it is being actually taught and encourage everyone to understand and learn independently, with the help of activities such as Mind Mapping and exciting discussions.
- Plan and execute activities like science club, elocution, drawing, writing poetry on science, making models *etc.* to develop positive attitude among children environment, biodiversity, ecological balance *etc.*
- As a part of continuous comprehensive evaluation, observe and record children's learning abilities during various activities conducted in classroom, laboratory and field.
- We believe, you must have realized that the learning of science and scientific thinking are not mere drilling of the lessons but, in fact, a valuable exercise in motivating the children to explore solutions to problems all around by themselves systematically and preparing them to meet life challenges properly.



Dear Students...

Learning science does not mean scoring good marks in the subject. Competencies like thinking logically and working systematically, learned through it, have to be practiced in daily life. To achieve this, instead of memorizing the scientific theories by rote, one must be able to study them analytically. That means, in order to understand the concepts of science, you need to proceed by discussing, describing, conducting experiments to verify, making observations, confirming with your own ideas and drawing conclusions. This text helps you to learn in that way.

What you need to do to achieve such things:

- Thoroughly go through each lesson before the teacher actually deals with it.
- Note down the points you came across so that you can grasp the lesson better.
- Think of the principles in the lesson. Identify the concepts you need to know further, to understand the lesson in depth.
- Do not hesitate to discuss analytically about the questions given under the sub-heading 'Think and Discuss' with your friends or teachers.
- You may get some doubts while conducting an experiment or discussing about a lesson. Express them freely and clearly.
- Plan to implement experiment/lab periods together with teachers, to understand the concepts clearly. While learning through the experiments you may come to know many more things.
- Find out alternatives based on your own thoughts.
- Relate each lesson to daily life situations.
- Observe how each lesson is helpful to conserve nature. Try to do so.
- Work as a group during interviews and field trips. Preparing reports and displaying them is a must.
- List out the observations regarding each lesson to be carried through internet, school library and laboratory.
- Whether in note book or exams, write analytically, expressing your own opinions.
- Read books related to your text book, as many as you can.
- You organize yourself the Science Club programs in your school.
- Observe problems faced by the people in your locality and find out what solutions you can suggest through your science classroom.
- Discuss the things you learned in your science class with farmers, artisans *etc.*

Chief Advisor & Editor

Prof. Kamal Mahendroo, Vidya Bhawan Education Resource Centre, Udaipur, Rajasthan.

Editors

Dr.B. Krishnarajulu Naidu, Retd., Professor of Physics, Osmania University, Hyderabad.

Dr.M. Adinarayana, Retd., Professor of Chemistry, Osmania University, Hyderabad.

Dr. Nannuru Upendar Reddy, Professor & Head C&T Dept., SCERT., Hyderabad.

Writers

Dr. TVS Ramesh, C&T Dept., SCERT, Hyderabad

Sri M. Ramabrahmam, Lecturer, Govt. IASE, Masabtank & Coordinator, SCERT, Hyderabad

Dr. P. Shankar, Asst. Professor, IASE, O.U., Hyderabad & Coordinator, SCERT, Hyderabad

Dr.K. Suresh, SA, ZPHS Pasaragonda, Warangal.

Sri V. Gurunadha Rao, SA, ZPPSS Parvathagiri, Warangal.

Sri Dandala Madhusudhana Reddy, SA, ZPHS Munagala, Nalgonda.

Sri R. Ananda Kumar, SA, ZPHS Laxmipuram, Visakhapatnam.

Sri K.V.K. Srikanth, SA, GTWAHS S.L.Puram, Srikakulam.

Sri M. Eswara Rao, SA, GHS Sompeta, Srikakulam

Sri S. Naushad Ali, SA, ZPHS G.D. Nellore, Chittoor.

Sri Y. Venkat Reddy, SA, ZPHS Chivemla, Nalgonda.

Sri A. Nagaraja Sekhar, SA, ZPHS, Chathakonda, Khammam.

Academic Support

Prof. V. Sudhakar, Dept of Education, EFLU, Hyderabad.

Miss. Preeti Misra, Vidya Bhawan Education Resource Centre, Udaipur, Rajasthan.

Mr Kishore Darak, Vidya Bhawan Education Resource Centre, Udaipur, Rajasthan.

Illustrator, Layout and Cover Page Designers

Sri K. Sudhakara Chary, SGT, UPS Neelikurthy, Warangal.

Sri Kishan Thatoju, Graphic Designer, C&T Dept., SCERT, Hyderabad.

Sri Kurra Suresh Babu, B.Tech, MA., MPhil., Mana Media Graphics, Hyderabad.

Sri Md. Ayyub Ahmed, S.A., Z.P. H.S U/M, Atmakur, Mahbubnagar.

Textbook Publication Team

Director, SCERT, Hyderabad.

Director, Govt. Text Book Press, Hyderabad.

Prof. & HoD, Dept. of Curriculum & Textbooks, SCERT, Hyderabad.

QR CODE TEAM



